



OWNER'S MANUAL

880 / 890

INSTALLATION, OPERATION, MAINTENANCE & PARTS

**NOTE: MANUAL including SPECIFICATIONS, subject to change without notice
All ratings specified are based on structural factors only,
not vehicle capacities or capabilities.**



Miller Industries Towing Equipment Inc.
8503 Hilltop Drive
Ooltewah, Tennessee 37363
Phone (423) 238-7227 i FAX (423) 238-7237

FORM NO. 9120300
06 / 99
PRICE \$25.00

LIMITED WARRANTY

MILLER INDUSTRIES TOWING EQUIPMENT INC., hereinafter referred to as MILLER, warrants to the original purchaser that each new MILLER wrecker or other MILLER products will be free from defects in material and workmanship for a period of twelve (12) months from date placed in service, but in no event shall such warranty period exceed twenty-four (24) months from date of manufacture by MILLER. The purchaser must promptly notify MILLER in writing of any failure in material or workmanship. In no event shall MILLER accept such notification later than twenty-four (24) months from date of delivery or twelve (12) months from date placed in service, whichever is earlier.

MILLER's obligation under this warranty, statutory or otherwise, is limited to the repair or replacement at the MILLER factory, or at a point designated by MILLER, of such part or parts as shall appear upon inspection by MILLER to be defective in material or workmanship. New or remanufactured parts will be used for any replacement at MILLER's option. This warranty is not transferable. This warranty does not obligate MILLER to bear the cost of labor or transportation charges in connection with the repair or replacement of any parts found to be defective, nor shall it apply to a product upon which repairs or alterations have been made unless authorized by MILLER.

EXCEPT AS EXPRESSLY SET FORTH IN THIS WARRANTY, MILLER MAKES NO OTHER WARRANTY, EXPRESS OR IMPLIED, AND HEREBY DISCLAIMS ALL OTHER WARRANTIES INCLUDING, BUT NOT LIMITED TO, THE IMPLIED WARRANTIES OF MERCHANTABILITY AND FITNESS FOR A PARTICULAR PURPOSE. MILLER shall in no event be liable for claimed downtime, claimed loss of profits or goodwill, or any other special, incidental, indirect, or consequential damages concerning or relating to any product or parts, whether based on negligence, strict liability, breach of contract, breach of warranty, misrepresentation or any other legal theory, regardless of whether the loss resulted from any general or particular requirement which MILLER knew or had reason to know about at the time of sale.

MILLER MAKES NO WARRANTY, EXPRESS OR IMPLIED, AS TO THE FINISHED PRODUCTS MANUFACTURED OR SUPPLIED BY ANOTHER MANUFACTURER AND SUPPLIED BY MILLER TO PURCHASER, including, but not limited to, any vehicle to which a MILLER product may be affixed or any accessories or wire rope, and MILLER EXPRESSLY DISCLAIMS ANY IMPLIED WARRANTIES OF MERCHANTABILITY OR FITNESS FOR A PARTICULAR PURPOSE AS TO SUCH EQUIPMENT OR PRODUCTS. This language shall in no way affect or diminish the rights of the purchaser to rely on such warranties as are extended by such manufacturers or suppliers. MILLER shall, to the extent permitted under applicable law, pass on to the purchaser such manufacturer's or seller's warranty.

MILLER, whose policy is one of continuous improvement, reserves the right to improve its products through changes in design or materials as it may deem desirable without being obligated to incorporate such changes in products previously sold. This warranty is not intended to cover or include the following items, which are set forth by way of example and not limitation:

- A. Normal deterioration of trim, paint, lettering, and appearance items due to wear or exposure to weather, road conditions, road treatments, etc.
- B. Any damage or defect due to accident, misuse, abuse, improper or unauthorized repairs, failure to provide reasonable and necessary maintenance, or uses for which the equipment was not designed or intended.
- C. Alterations or modifications that affect performance, operation or reliability.
- D. Normal maintenance parts including, but not limited to, wear pads, bushings, wire rope, mud flaps, fenderettes, light bulbs, hydraulic oil, filters, and tow sling belts.

IT IS EXPRESSLY UNDERSTOOD THAT MILLER MAKES NO IMPLIED WARRANTY THAT MILLER PRODUCTS SHALL BE FIT FOR THE PURPOSE OF LIFTING OR MOVING PEOPLE OR FOR ANY OTHER IMPROPER USE.



Miller Industries Towing Equipment Inc.
8503 Hilltop Drive
Ooltewah, Tennessee 37363

Telephone (423) 238-4171

SERIAL NUMBER



Painting Instructions

The primed unit that you have received has been cleaned, and iron phosphated with Enchem pretreatment. It has also received a cross coat of E2G973 Vinyl Wash Primer, followed by two coats of E2W823 High Solids Urethane Primer.

To prepare the surface for painting with topcoat, Sherwin Williams suggests the following:

1. Wash surface to be painted with a mild detergent in hot water. Rinse well and wipe dry with a clean cloth.
2. Solvent clean with Sher-Will-Clean R7K156, or Aqua Mate Low V.O.C. Surface Cleaner W4K157. Wipe dry with a clean cloth.
3. Scuff the surface with 320 grit sandpaper on a random orbital sander. Hand scuffing with Scotch-Brite is not acceptable, it is not thorough enough.

NOTES

Scotch-Brite is made to fit on a special pad for a random orbital sander. By applying it with an orbital sander will ensure proper scuffing. Place emphasis on scuffing thoroughly, and not on sanding exhaustively to the point of removing generous amounts of primer. You will need to ensure that your unit is not exposed to the sun for a long period of time. Exposure will cause the sun's U.V. rays to break down the chemical balance of the primer, causing it to flake and turn powdery.

Thank you for investing in a VULCAN product.

Sincerely,
VULCAN EQUIPMENT CO., INC.

NOTICE

This manual gives important safety instructions for certain models of Vulcan towing and recovery equipment. These products should not be operated by anyone who has not read this manual. Following these instructions can keep you and others from getting seriously injured.

Vulcan towing and recovery products are intended for use by persons engaged in towing and recovery as a profession. They are not intended for use by persons unskilled or untrained in this field. Vulcan towing and recovery products should not be loaned, rented or leased to anyone lacking such skills.

If you own or manage a towing operation, you should require all operators of these Vulcan products to read this manual. As an employer, you are responsible for instructing your employees how to operate the equipment used in your business. Requiring them to read this manual helps you to fulfill this obligation.

We recommend that you have all your operators sign the log in the back of the manual when they read this manual.

This manual is furnished free with Vulcan products. If it gets lost or damaged, contact Vulcan for a free replacement copy.

CONTENTS

	Page No.
SECTION I	
SAFETY	I-1 thru I-6
SECTION II	
RATINGS	II-1 thru II-3
SECTION III	
OPERATION	III-1 thru III-6
SECTION IV	
OPERATING THE UNDERLIFT	IV-1 thru IV-18
HOOING UP THE TOW SLING	IV-18 thru IV-22
RECOVERY	IV-25 thru IV-32
SECTION V	
SAFE STEERING LOAD, GVWR, GAWR, & GCWR	V-1 thru V-10
SECTION VI	
MAINTENANCE	VI-2 thru VI-14
LUBRICATION DIAGRAM	VI-11
TROUBLESHOOTING	VI-12 thru VI-14
SECTION VII	
INSTALLATION	VII-1 thru VII-14
SECTION VIII	
REPLACEMENT PARTS	VIII-1 thru VIII-49
APPENDIX A	A-1 thru A-5

READ THIS MANUAL CAREFULLY BEFORE USING THIS PRODUCT

PURPOSE AND SCOPE

This manual provides instructions for operation, maintenance, replacement parts, and installation of the Vulcan Model 880/890 wrecker, body and wheel lift.

INTENDED USE

This product is intended for use only by trained professional operators who have carefully read and understood the contents of this manual.

This product is intended to recover and tow passenger cars, pick up trucks, vans or other vehicles that do not exceed the lift or tow ratings of the equipment.

This manual shows how to properly use the towing equipment. However, you must refer to towing recommendations of the vehicle manufacturer or a certified towing manual to avoid damage to transmissions or other components of the towed vehicle.

This product is not intended for rescue work.

This product is not intended for lifting persons.

The Vulcan Model 880/890 are intended for installation and use on truck chassis with minimum 60" CA and 14,500 to 22,000 lb. GVWR.

SAFETY

SAFETY CONSIDERATIONS

Read this manual carefully and understand the operation of this product before attempting to use it.

Observe all federal, state, and municipal laws including applicable OSHA requirements.

Do not exceed equipment or chassis ratings.

Always use safety chains when towing.

Use only original equipment manufacturer (OEM) replacement parts.

As a towing professional, you will encounter many unique circumstances and environments when operating this equipment. It is impossible for Vulcan to warn of all the possible dangers you will encounter, but this manual will inform you of the most common hazards we know about.

No manual can substitute for common sense. Always be aware of your surroundings (including bystanders), and operate the equipment in a good, safe, manner. A safe recovery or tow is much more important than speed. Always operate the equipment with caution and safety in mind.

Do not operate the equipment while under the influence of alcohol or prescription or nonprescription drugs.

Failure to follow the instructions in this manual could create serious defects in the equipment. If any instruction in this manual is not clear to you contact Vulcan Equipment Co. for clarification.

SAFETY TIPS

ARRIVAL AT THE WORK SITE

This section contains safety tips that you should follow to help protect you, others and your equipment upon arrival at the work site. Make sure that all equipment inspections listed on pages 67 thru 75 have been performed.

1. Engage emergency brake before commencing recovery work or hooking up to a disabled vehicle.
2. Activate equipment beacons and set out traffic warning signs or flares approximately 100 yards behind and ahead of the work site. If traffic must be temporarily blocked, proceed with caution or allow police to manage the traffic. Follow all local, state and federal guidelines.
3. Wear relatively close fitting clothing, reflective material, safety glasses, gloves, safety shoes, and other safety equipment as dictated by the situation.
4. Call ambulance, fire department, or police if necessary.
5. Beware of all dangers including fire, electrical wires, toxic chemicals, unsteady equipment, uneven or shifting terrain, and potential traffic hazards around the work site.
6. Inspect the scene. Make sure that recovering or towing the disabled vehicle will not exceed the ratings of your equipment. Send for a larger tow truck if necessary. Do not exceed the ratings of your equipment under any circumstances.

SAFETY TIPS FOR OPERATING THE RECOVERY BOOM AND WINCHES

This section contains safety tips that you should follow to help protect you, others and your equipment when operating the recovery boom and winches.

1. Do not operate your Vulcan equipment when bystanders are near by.
2. Always operate your equipment on a solid level surface.
3. Your equipment is designed with dual controls. Do not stand on the side of your truck next to traffic. Do not stand between your truck and the vehicle you are attempting to recover. Always stand in a safe work zone.
4. Always back the recovery vehicle as close as possible to the disabled vehicle. Position the rear of the recovery vehicle towards the disabled vehicle prior to rigging winch cables.
5. Remember that extending the boom significantly decreases the rating. Operate within the ratings of your equipment. (See graph in Appendix A.)
6. When operating the boom, be aware of any overhead obstructions or electrical wires. Do not operate near power lines.
7. Never place yourself or others behind the boom or under a suspended load. Personnel should never stand along side cable or chain systems under load.
8. Always keep the load as close as possible to the ground. If feasible, keep the load within one foot of the ground.

**SAFETY TIPS FOR OPERATING THE RECOVERY BOOM AND WINCHES
(cont'd)**

9. Never use the recovery boom, winches or wheel lift to lift people.
10. Operate all controls slowly and smoothly to avoid shock loads that could damage your equipment. Also, use caution to avoid load shifts that might cause shock loads when combined winching operations are being performed. Shock loads can exceed equipment ratings and cause serious damage to the equipment as well as injuries.
11. When winding the winch cable in, do not allow the cable to crisscross.
12. Always maintain a minimum of five wraps of cable on the winch drum when winching. Winch cable tensioners are only intended to keep the cable from spoiling out during slack or no-load conditions.
13. Do not attach the winch cable hook directly to the load. First attach a chain or sling to a substantial member of the load. Then, attach the winch cable hook to the chain or sling.
14. Before winching, inspect the sheave wheels and their housings as well as your snatch blocks and cable for wear or damage.
15. Never disengage the winch drum clutch when the cable is loaded.
16. Never tie down the front end of your tow truck for recovery work or heavy lifts. Frame damage may result if you do so.

SAFETY TIPS FOR TOWING A DISABLED VEHICLE

This section contains safety tips that you should follow to help protect you, others and your equipment when towing a disabled vehicle.

1. Always determine how much load you will be lifting. Make sure that towing the disabled vehicle will not exceed the ratings of your equipment. Send for a larger tow truck if necessary. Do not exceed the ratings of your equipment under any circumstances.
2. When towing a vehicle using a rear end lift, the front wheels of the vehicle must be straight and the steering wheel locked and secured with a steering wheel clamp device to ensure that the vehicle will track straight and not swing out into the path of oncoming traffic.
3. Before towing, always secure the load with safety chains. Make sure all items on the deck are securely stored and the tool box doors latched.
4. Check the underlift at least once every three hours on long tows to make sure there has been no hydraulic leak down.
5. Before towing with the wheel grid, always insert a stop pin in the top hole of the retainer arm closest to the receiving collar. Insert a second pin into the wheel retainer collar to prevent side movement of the collar.
6. Attach magnetic tow lights to the disabled vehicle.
7. Be aware of the fact that the closer you bring the disabled vehicle to the back of the truck when towing, the more weight you will retain on the front axle for steering. However, you must allow adequate clearance for turning.

SAFETY TIPS FOR TOWING A DISABLED VEHICLE (cont'd)

8. Never travel down the road with your P.T.O. engaged. Serious damage to the transmission or pump will result!
9. In the event of a sudden or "panic" stop, always inspect your load before proceeding. If necessary, remove the load in a safe area and hook up again.
10. Always make sure that your recovery boom and the disabled vehicle are not raised too high when travelling through a low clearance area such as an overpass or parking garage.
11. Always follow state and local laws governing the use of rotating or flashing beacons.
12. Never allow anyone to ride in a vehicle while it is being towed.

OTHER SAFETY TIPS

1. Vulcan does not recommend climbing on the deck. If it does become necessary to climb on the deck, be extremely cautious. Even tread plate can become slippery!
2. Use only original Vulcan replacement parts. Failure to do so voids all warranty.
3. Vulcan's wheel retainer system is designed only for use on products manufactured by Vulcan. Retrofitting the Vulcan wheel retainer system to other equipment is dangerous and is an illegal violation of Vulcan Equipment Company Inc.'s patent rights.
4. Avoid jack-knifing the towed vehicle while maneuvering it into a parking space. Jack-knifing can damage your towing equipment making it unsafe for continued use.

RATINGS

WRECKER BOOM RATINGS

880/8T

Fully retracted 8 tons (16,000 lbs.)

Fully extended 2 tons (4,000 lbs.)

880/10T

Fully retracted 10 tons (20,000 lbs.)

Fully extended 2 tons (4,000 lbs.)

890/10T

Fully retracted 10 tons (20,000 lbs.)

Fully extended 2 tons (4,000 lbs.)

MAXIMUM BOOM HEIGHT

880 140 inches

890 158 inches

WRECKER BOOM LENGTH (from tailboard)

880

Fully retracted 6 1/2 inches

Fully extended 48 1/2 inches

890

Fully retracted 18 inches

Fully extended 76 inches

RATINGS (cont'd)

WRECKER WINCH RATINGS

880/8T
Line pull (1st layer) 8,000 lbs.

890/880/10T
Line pull (1st layer) 10,000 lbs.

WINCH CABLE 880/890

Type 6x19 Fiber Center IPS
Dia. & Std. Length 3/8" x 100 ft.
Working Limit 3,500 lbs.

WHEEL LIFT RATING W/WHEEL RETAINERS

880
Retracted 4,000 lbs.
Extended 4,000 lbs.

890
Retracted 6,000 lbs.
Extended 4,000 lbs.

UNDERLIFT RATING W/AXLE FORKS (890 ONLY)

Retracted 6,000 lbs.
Extended 6,000 lbs.

WHEEL LIFT REACH 880/890 (past tailboard)

Fully Retracted 29 inches
Fully Extended 66 inches

RATINGS (cont'd)

WHEEL LIFT TILT (up & down)

880/890 16 degrees

WHEEL LIFT TOW RATING

880 7,500 lbs.

890 10,000 lbs.

MINIMUM CHASSIS GVWR 14,500 lbs.



**ALL RATINGS APPLY ONLY TO THE WRECKER AND
UNDERLIFT STRUCTURE AND NOT THE TRUCK
CHASSIS. CHASSIS SIZE, WEIGHT AND RATINGS MAY
LIMIT ACTUAL RECOVERY AND TOW LOAD CAPACITY.**

OPERATION

THROTTLE CONTROL

Most tow trucks have a remote throttle control which controls engine speed. The remote throttle control is usually located on the wrecker body or in the cab of the truck. To obtain the best power output and highest efficiency, set the engine speed for its peak output torque. This speed is usually between 1200 to 1300 RPM. (See Figure 3-1.)

Do not set engine speeds that will drive the hydraulic pump in excess of 1800 RPM.

Always reset the throttle to normal idle speed before moving the tow truck.

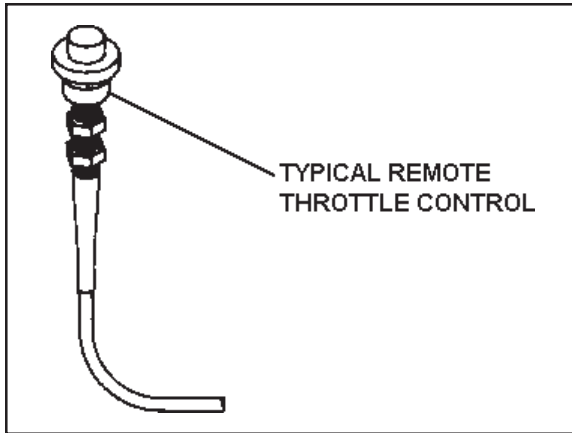

Figure 3-1.

WINCH CLUTCH CONTROL

The winch clutch control is on the winch. Use it to engage and release the cable drum. Engage it before operating the cable drum under power. (See Figure 3-2.)

WINCH CLUTCH CONTROL (cont'd)

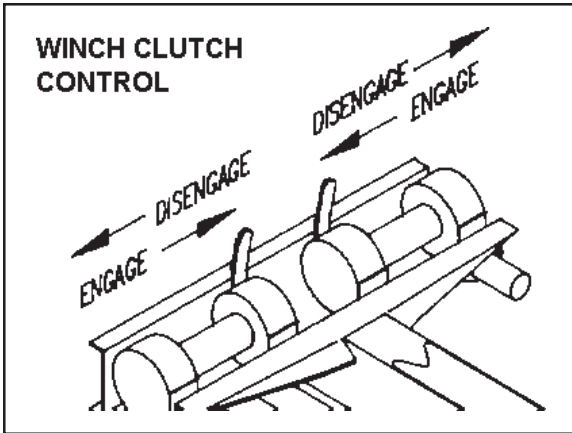

Figure 3-2.



FULLY ENGAGE THE CLUTCH BEFORE OPERATING THE WINCH. FAILURE TO ENGAGE THE CLUTCH FULLY MAY ALLOW THE WINCH TO RELEASE UNEXPECTEDLY WHEN LOADED, CAUSING AN ACCIDENT WITH SEVERE INJURIES OR DEATH.

Release the clutch to pull out long lengths of cable by hand. This will save time and avoid unnecessary wear on internal winch components. Never release the winch clutch with the cable loaded!

WRECKER BOOM AND WINCH CONTROLS

The wrecker boom and winch controls allow you to operate the wrecker boom or winches under power. The controls have handles connected by linkage to spools of hydraulic control valves. The controls have no effect unless the hydraulic pump is operating. The pump operates only when the engine is running and the PTO engaged.

WRECKER BOOM AND WINCH CONTROLS (cont'd)

Wrecker boom and winch controls are located on top of the body above the wheel opening. Each control handle has two operating directions. Labels on the control rod handles display the function and direction of movement, when a handle is in the center position the function should hold its position even when fully loaded and the PTO disengaged. All control handles should return to their center position when released. Always be sure that the handles return to their center position and the movement they control stops.

One set of control handles is mounted on one side of the body. A duplicate set is mounted on the opposite side of the body. Having two sets of controls provides operating convenience and increases safety. It allows the operator to stand on the side of the truck away from passing traffic or other hazards.

Use the winch controls to control the in and out movement of the winch cable under power. Make sure the winch clutch is engaged before operating the winch controls. (See Figure 3-3.)



NEVER CONTINUE TO WIND IN CABLE AFTER THE HOOK HAS MADE CONTACT WITH THE BOOM END. WINDING THE CABLE TIGHTER COULD RESULT IN DAMAGE TO THE BOOM OR CABLE.



NEVER UNWIND ALL THE CABLE FROM THE WINCH DRUM WHILE LOADED. KEEP AT LEAST FIVE WRAPS OF CABLE ON THE DRUM TO PREVENT THE CABLE FROM PULLING LOOSE FROM THE DRUM.

WRECKER BOOM AND WINCH CONTROLS (cont'd)

Use the boom up/down control to raise and lower the Wrecker boom. (See Figure 3-3.)

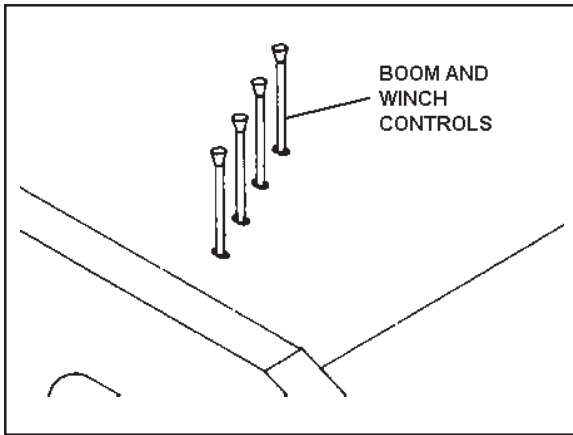

Figure 3-3.

Use the boom in/out control to extend or retract the wrecker boom. (Refer to Figure 3-3.)

UNDERLIFT CONTROLS

The underlift controls are located at the rear of the body. Each control handle has two operating directions. Labels on the control rod handles display the function and direction of movement.

When a handle is in the center position the function should hold its position even when fully loaded and the PTO released.

All control handles should return to their center position when released. Be sure the handles return to their center position and the movement they control stops. (See Figure 3-4.)

If the handles do not return to the center position or if hydraulic leak down is noted, service immediately. Do not continue to operate the equipment until repairs are made.

UNDERLIFT CONTROLS (cont'd)

One set of control handles is mounted on one side of the body. A duplicate set is mounted on the opposite side of the body. Having two sets of controls provides operating convenience and increases safety. It allows the operator to stand on the side of the truck away from passing traffic or other hazards.

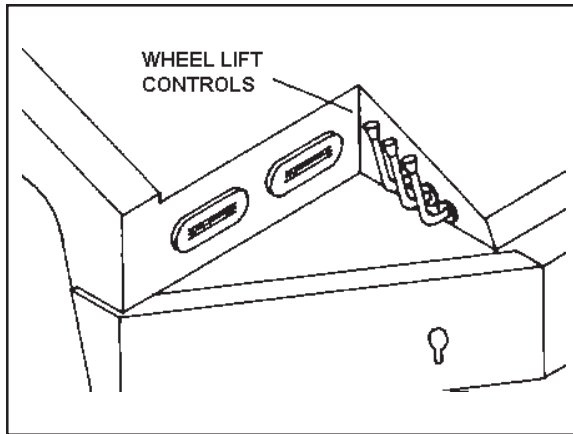

Figure 3-4.

Use the underlift raise up/down control to raise and lower the underlift boom. The underlift raise up/down movement is independent of other underlift movements. (Refer to Figure 3-4.)

Use the underlift tilt up/down control to tilt the underlift boom up or down. The underlift tilt up/down movement is independent of other underlift movements. The tilt movement allows the boom to tilt up or down from the horizontal position regardless of elevation or extension. Tilting the boom makes it easier to load cars on unlevelled ground. Tilting a car upwards before retracting the boom provides extra clearance for low air dams and spoilers. (Refer to Figure 3-4.)

Use the underlift boom in/out control to extend or retract the underlift boom. Use these movements when loading a vehicle for towing. (Refer to Figure 3-4.)

UNDERLIFT CONTROLS (cont'd)



NEVER STAND BETWEEN THE TOW TRUCK AND THE VEHICLE YOU ARE ATTEMPTING TO LOAD WITH THE UNDERLIFT. IF THE VEHICLE WERE TO ROLL FREE OR SHIFT SUDDENLY, YOU COULD BE SERIOUSLY INJURED OR KILLED.



ALWAYS STAND ON THE SIDE OF THE TOW TRUCK AWAY FROM TRAFFIC WHEN OPERATING THE CONTROLS. FAILURE TO DO SO COULD ALLOW YOU TO BE STRUCK BY ONCOMING TRAFFIC CAUSING SERIOUS INJURIES OR DEATH.

OPERATING THE UNDERLIFT

The following procedures were carefully developed to provide maximum safety for the operator and for the public. If you must use different procedures, make sure you include all the safety tips we describe.

SETTING UP THE UNDERLIFT

The underlift can be set up for towing a vehicle using either the wheel retainer system or the underlift forks. Switching from one to the other is fast and simple. If you need to switch, do it before you start the loading process.

LOADING THE UNDERLIFT USING WHEEL RETAINERS

1. Check the vehicle you are going to tow to make sure it can not roll free when hooking up for towing. To do that, either block its wheels, apply the parking brakes, or shift the transmission into PARK.
2. Turn the steering wheel of the vehicle to position its front wheels straight ahead.
3. When towing a vehicle from the rear, so its front wheels remain on the ground, secure its steering wheel utilizing a towing certified steering wheel lock. Do not depend on the vehicle's steering column lock.



FAILURE TO PROPERLY SECURE THE STEERING WHEEL COULD PERMIT THE VEHICLE TO SWING OUT INTO ANOTHER LANE OF TRAFFIC AND CAUSE A SERIOUS ACCIDENT.

LOADING THE UNDERLIFT USING WHEEL RETAINERS (cont'd)

4. Fully retract the stinger of the underlift. Adjust the height of the cross bar so it is 1 or 2 inches above the ground. Make sure it is low enough to clear the underside of the vehicle being loaded. (See Figure 4-1.)

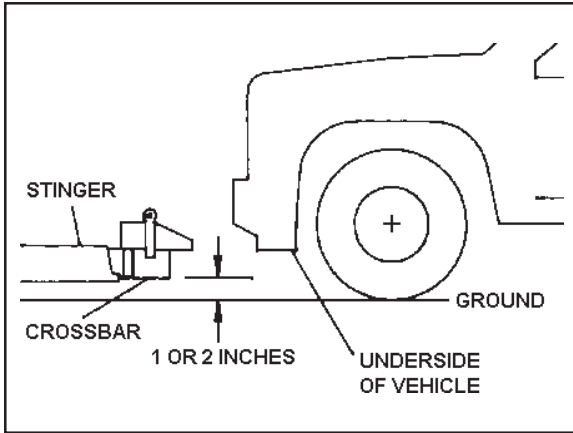

Figure 4-1.

5. Adjust the wheel grids on the cross bar to match the track width of the vehicle. Make sure the locking screws for the grids are tight. (See Figure 4-2.)

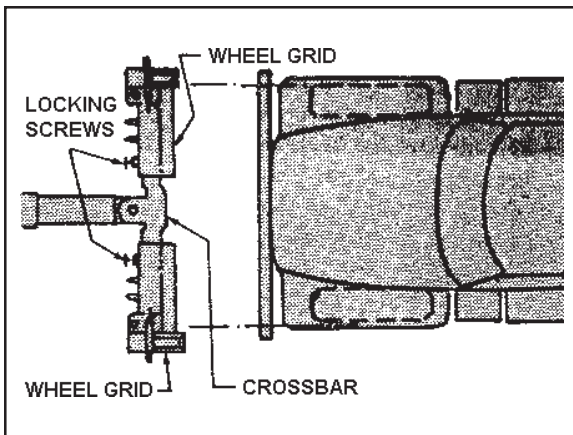

Figure 4-2.

LOADING THE UNDERLIFT USING WHEEL RETAINERS (cont'd)

6. Retract the wheel stop pins. Remove the safety pin from the receivers of the wheel grids. Swing the receivers outwards. (See Figure 4-3.)

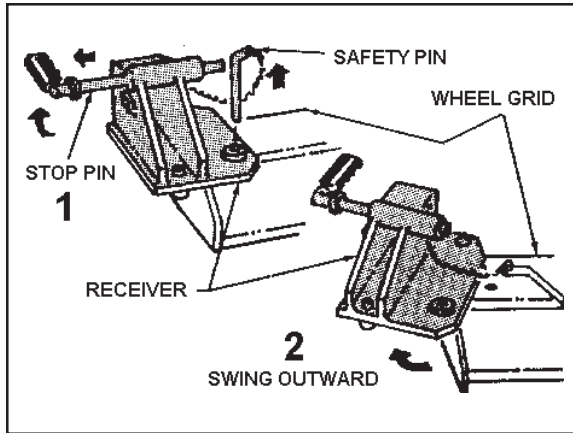

Figure 4-3.

7. Remove the two wheel retainers from the tow truck and lay each one on the ground next to the wheel to be loaded.
8. Maneuver the tow truck into position for loading. The cross bar of the underlift should go under the vehicle. Stop backing when the tailboard of the tow truck is close to the vehicle. Apply the truck's parking brakes. (See Figure 4-4.)

LOADING THE UNDERLIFT USING WHEEL RETAINERS (cont'd)

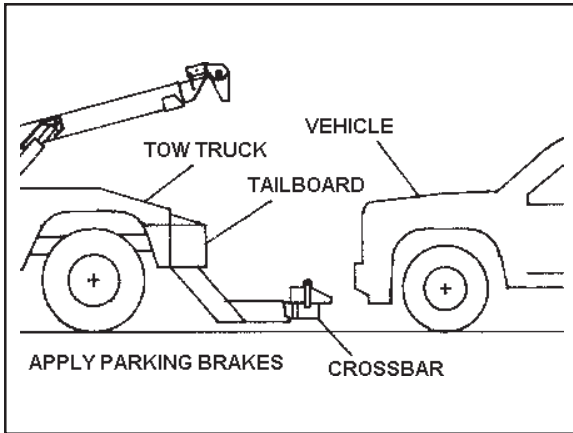

Figure 4-4.

9. Extend and lower the stinger so the wheel grids on the cross bar touch the ground and both wheels.
10. At each wheel, insert the wheel retainer into its receiver. Leave about 1/2 inch space between the wheel and retainer when possible to allow the disabled vehicle's tire to sit lower in the wheel retainer mechanism. Swing the retainer into position so that the tire grip plate fits closely behind the tire. Make sure one of the holes in the bottom of the arm of the retainer engages the pin in the receiver, thereby locking the arm. (See Figure 4-5.)

LOADING THE UNDERLIFT USING WHEEL RETAINERS (cont'd)

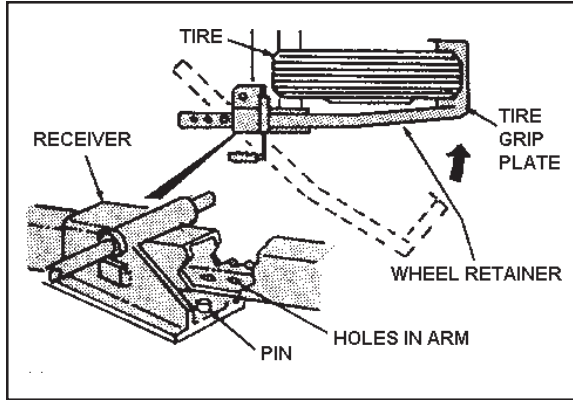



Figure 4-5.

11. At each wheel, insert the safety pin in a hole in the top of the arm, close to the receiver. (See Figure 4-6.)



WARNING

FAILURE TO PERFORM THIS STEP BEFORE RAISING THE VEHICLE MAY RESULT IN DAMAGE TO THE VEHICLE TRANSMISSION OR BRAKES.

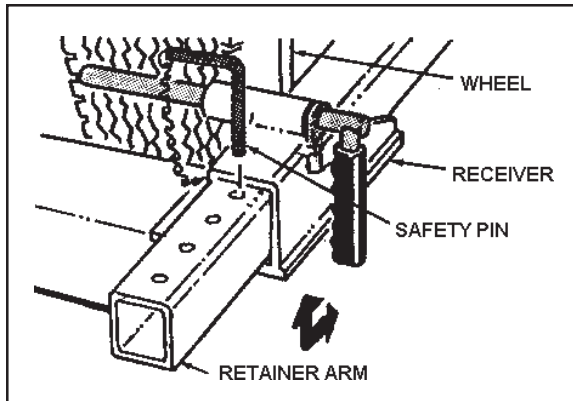

Figure 4-6.

LOADING THE UNDERLIFT USING WHEEL RETAINERS (cont'd)

12. At each wheel, position the stop pin so it is directly in front of the tire. (Refer to Figure 4-6.) In the case of a broken tie rod or flat tire, the extra safety pin should be used to lock horizontal movement of the wheel retainer receiver. (Refer to Figure 4-3).
13. On the towed vehicle, release the parking brake and shift the transmission into NEUTRAL.
14. Position the underlift so the towed vehicle is in position for towing. You may need to temporarily tilt the stinger to gain extra clearance at the vehicle's air dam or under parts as you move it into position for towing. The vehicle should be positioned as far forward as possible while maintaining clearance for turns. This keeps more weight on the front wheels of the tow truck for safer steering. Tilt the stinger as needed to clear the under carriage of the disabled vehicle, but keep the stinger as close to horizontal as possible. (See figure 4-7.)

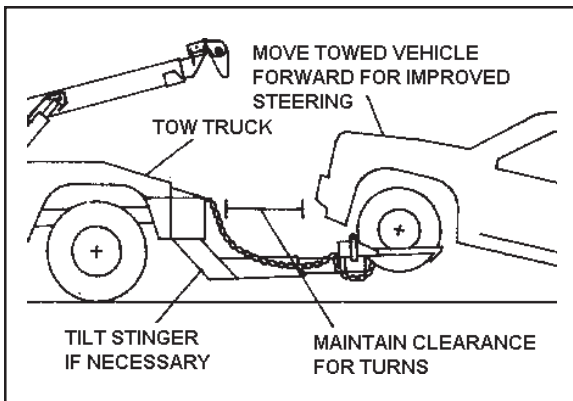

Figure 4-7.

LOADING THE UNDERLIFT USING WHEEL RETAINERS (cont'd)

15. Connect two safety chains from the eyes in the body of the tow truck to the axle or frame of the towed vehicle. Be sure to cross the chains and leave only enough slack in them to permit free turning of the vehicles. Near the middle of each chain, attach it to the grab hooks on the wheel grids. Make sure there is enough slack in the aft ends of the chains so the suspension of the vehicle can operate freely. (See Figure 4-8.)



16. Check the trailing end of the vehicle for adequate ground clearance. Remove wheel chocks if used.

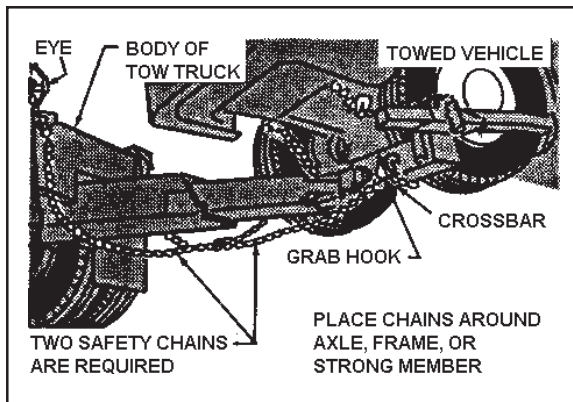

Figure 4-8.

17. If you loaded the drive wheels into the underlift, shift the transmission into PARK or into REVERSE. If you are towing with the drive wheels on the ground, make sure the transmission is in NEUTRAL.

LOADING THE UNDERLIFT USING WHEEL RETAINERS (cont'd)

18. Release the parking brakes.
19. Make sure the towed vehicle's wheels that remain on the ground are free to roll. Make sure they are not locked by the transmission or parking brakes.



IF YOU ATTEMPT TO START THE TOW WHILE THE WHEELS ON THE GROUND ARE LOCKED, YOU MAY DAMAGE THE UNDERLIFT AND THE TOWED VEHICLE.

20. Drive the tow truck with extra care.

UNLOADING THE WHEEL RETAINERS

1. Position the tow truck for unloading and apply its parking brakes.
2. Remove the safety chains.
3. At each wheel, withdraw the stop pin from the front of the tire. (See figure 4-9.)
4. At each wheel, remove the safety pin from the top of the retainer arm near the receiver. (See figure 4-9.)

UNLOADING THE WHEEL RETAINERS (cont'd)

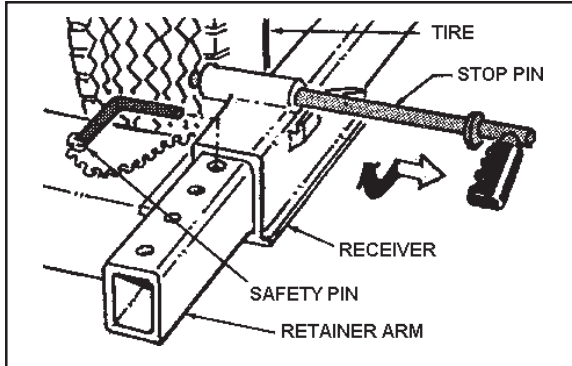



Figure 4-9.

5. Operate the underlift to lower the wheels to the ground until the tires barely touch. (See Figure 4-10.)

 **WARNING**

DO NOT LOWER THE UNDERLIFT FULLY AT THIS TIME. OTHERWISE THE WHEEL RETAINERS WILL UNLOCK, AND MAY ALLOW THE VEHICLE TO ROLL FREE.

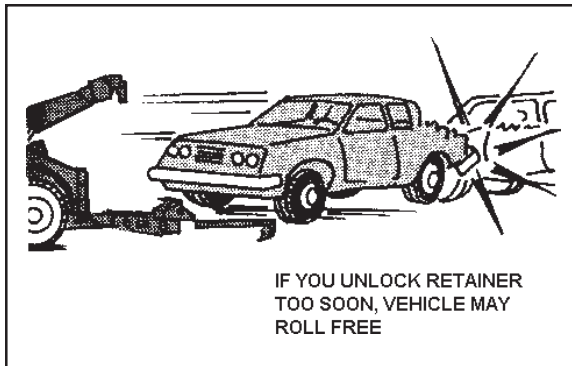

Figure 4-10.

UNLOADING THE WHEEL RETAINERS (cont'd)

6. On the towed vehicle, apply the parking brakes and shift the transmission into PARK or if manual transmission, shift into gear.
7. Operate the underlift to lower the cross bar all the way to the ground. This should automatically unlock the wheel retainers from the receivers. (See Figure 4-11.)

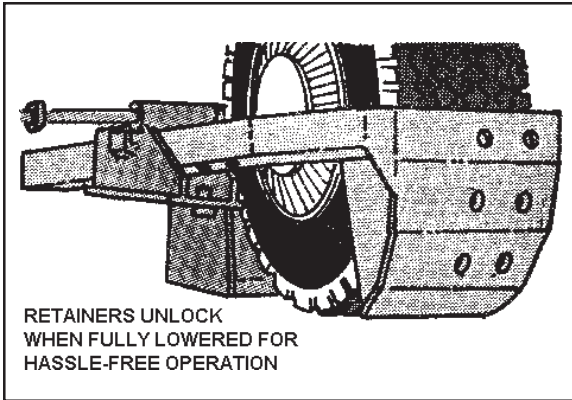

Figure 4-11.

8. Remove the wheel retainers and securely stow them in the storage area provided.
9. Swing the receivers inwards and lock them into place with the safety pins. Push in the tire stop pins.
10. Fully retract the stinger and raise it to about the height of the tailboard.

LOADING FLAT TIRES

Loading a wheel with a flat tire may not permit the retaining arm of the underlift to be positioned satisfactorily. As a result, the wheel may drop down too far in the retainer.

Using a 4-inch block may enable you to overcome this problem. Raise the wheel just enough to slide the block under the flat tire. Then lower the stinger and push the wheel retainer tight against the tire. Make sure the arm of the retainer locks into place. (See Figure 4-12.)

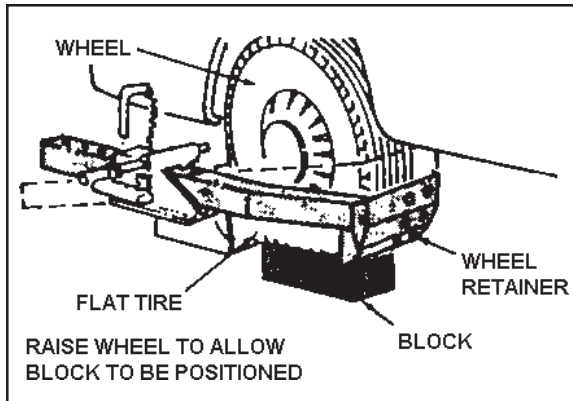

Figure 4-12.

If you can not use the underlift to raise the wheel with the flat tire, use a jack.

You may also need to use the wood block when unloading the wheel with the flat tire. Simply put the block under the tire before lowering the wheels.

LOADING THE UNDERLIFT USING FORKS (MODEL 890 ONLY)

To switch from the wheel retainer system to the fork holders, first remove the wheel grids.

After removing the grids, slide the fork holders on to the crossbar in order to use the forks. Make sure the lock pin of each fork holder engages a hole in the crossbar. (See Figure 4-13).

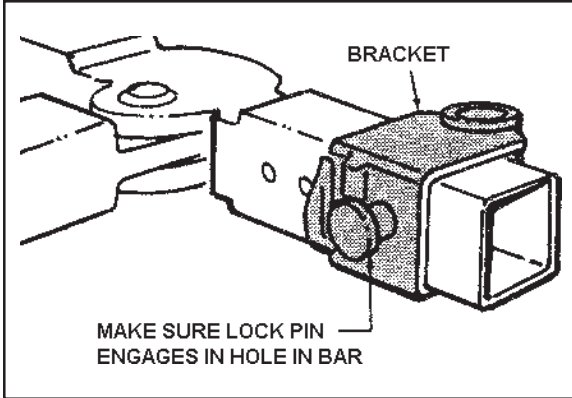

Figure 4-13.

1. Check the vehicle you are going to tow to make sure it can not roll free when hooking up for towing. To do that, either block its wheels, apply the parking brakes, or shift the transmission into PARK.
2. Turn the steering wheel of the vehicle to position its front wheels straight ahead.
3. When towing a vehicle so its front wheels remain on the ground, secure its steering wheel.

LOADING THE UNDERLIFT USING FORKS (cont'd)



**FAILURE TO PROPERLY SECURE THE STEERING WHEEL
COULD PERMIT THE VEHICLE TO SWING OUT INTO
ANOTHER LANE OF TRAFFIC AND CAUSE A SERIOUS
ACCIDENT.**

4. Fully retract the stinger of the underlift. Adjust the height of the crossbar so it is 1 or 2 inches above the ground. Make sure it is low enough to clear the underside of the vehicle being loaded.
5. Examine the underside of the vehicle and select pickup points suitable for towing. Your choice will usually be either the frame, axle or springs. (See Figure 4-14.)

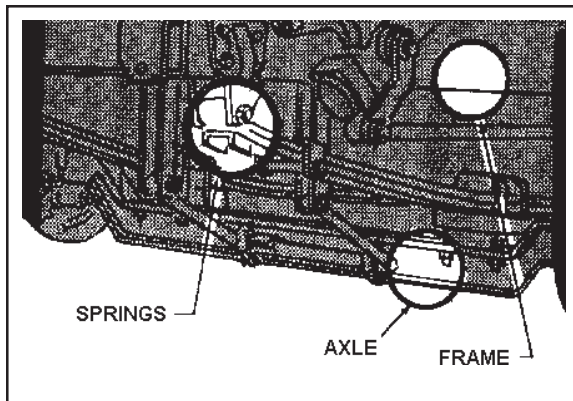

Figure 4-14.

6. Maneuver the tow truck into position for loading. The cross bar of the underlift should be slightly under the vehicle. Apply the tow truck's parking brakes.

LOADING THE UNDERLIFT USING FORKS (cont'd)

7. Position the fork holders on the crossbar to align with the pickup points on the vehicle. Make sure the lock pin of each fork holder engages a hole in the cross bar. (See Figure 4-15.)

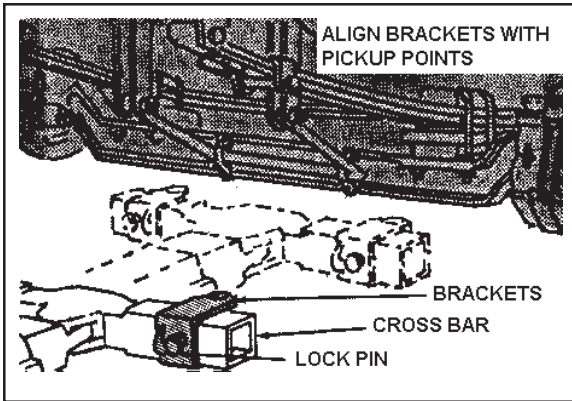

Figure 4-15.

8. Get out the underlift forks that are most suitable for the pickup points you picked earlier. Insert and secure the forks in the fork holders. Optional forks may need to be ordered from your Vulcan distributor to handle certain applications. (See Figure 4-16.)

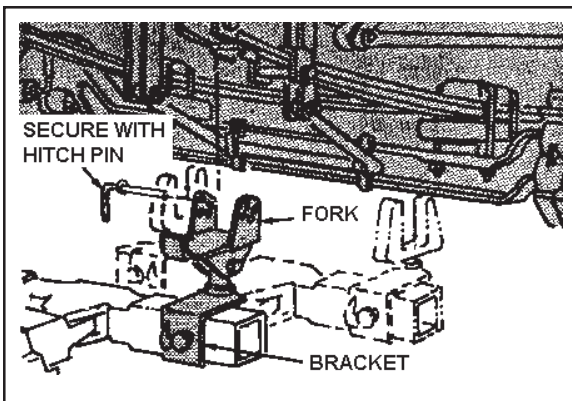

Figure 4-16.

LOADING THE UNDERLIFT USING FORKS (cont'd)

9. Position the stinger so the forks are in full contact with the pickup points.



KEEP CLEAR OF THE FORKS WHEN POSITIONING THE STINGER. FURTHERMORE, NEVER POSITION THE FORKS WHILE SOMEONE ELSE OPERATES THE CONTROLS. OTHERWISE, YOU COULD BE SERIOUSLY INJURED IF SOMETHING ACCIDENTLY SLIPS OR THERE IS A MISCUE WHEN USING THE CONTROLS.

10. On the towed vehicle, release the parking brake and shift the transmission into NEUTRAL.



FAILURE TO PERFORM THIS STEP BEFORE RAISING THE VEHICLE MAY RESULT IN DAMAGE TO THE VEHICLE TRANSMISSION OR BRAKES.

11. Operate the underlift to position the towed vehicle for towing. You may need to temporarily tilt the stinger to gain extra clearance at the vehicle's air dam or under parts as you move it into position for towing. The vehicle should be positioned as far forward as possible while maintaining clearance for turns. This keeps more weight on the front wheels of the tow truck for safer steering.

LOADING THE UNDERLIFT USING FORKS (cont'd)

12. Connect two safety chains from the tow truck to the axle or frame of the towed vehicle. The chains should be crossed and routed under the cross bar of the underlift. They should be attached to the axle or frame, then secured in the grab hooks on the fork holders, leaving some slack. The slack is needed because raising or lowering the stinger may cause the chains to tighten, depending on where they are attached to the vehicle. (See Figure 4-17.)

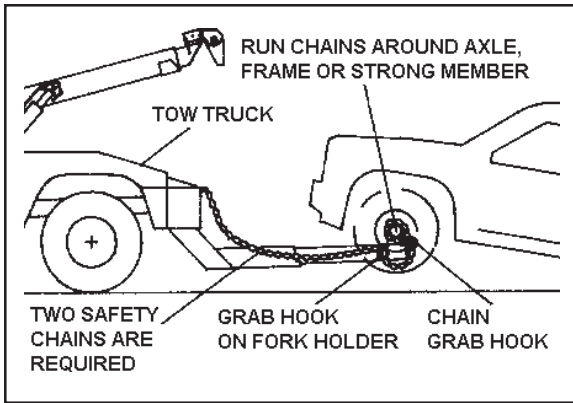

Figure 4-17.



FAILURE TO LEAVE SLACK IN THE SAFETY CHAINS COULD RESULT IN DAMAGE TO THE VEHICLE, TO THE CHAINS, OR TO THE GRAB HOOKS ON THE FORK HOLDERS.

The lengths of chain between the grab hooks and the body should have only enough slack to permit free turning of the vehicles. This slack can be adjusted at the key slots in the body.

LOADING THE UNDERLIFT USING FORKS (cont'd)

When properly used, the safety chains should prevent the towed vehicle from coming out of the forks and should prevent it from coming free of the wrecker in case the underlift fails.



**FAILURE TO USE SAFETY CHAINS WHEN TOWING
COULD CAUSE AN ACCIDENT WITH SERIOUS INJURIES
OR LOSS OF LIFE.**

13. Check the trailing end of the vehicle for adequate ground clearance. Remove wheel chocks if used.
14. If you raised the drive wheels for towing, shift the transmission into PARK or if manual transmission into REVERSE. If you are towing with the drive wheels on the ground. Make sure the transmission is in NEUTRAL.
15. Release the parking brakes.
16. Make sure the towed vehicle's wheels that remain on the ground are free to roll. Make sure they are not locked by the transmission or parking brakes.



**IF YOU ATTEMPT TO START THE TOW WHILE THE
WHEELS ON THE GROUND ARE LOCKED, YOU MAY
DAMAGE THE UNDERLIFT AND THE TOWED VEHICLE.**

17. Drive the tow truck with extra care.

UNLOADING THE UNDERLIFT WHEN USING FORKS

1. Position the tow truck for unloading and apply its parking brakes.
2. Remove the safety chains.
3. Operate the stinger to lower the wheels fully to the ground. Exercise extreme caution to ensure the forks continue to hold the vehicle.
4. On the towed vehicle, apply the parking brakes and shift the transmission into PARK or if manual transmission, into gear. Use wheel chocks if necessary.
5. Lower the stinger further and remove the underlift forks. Stow them in the tow truck.
6. Fully retract the stinger and tilt it to the stowed position.

OPTIONAL TOW SLING

If an optional tow sling is used, its lift ratings will differ from those of the underlift. Hence, when using a tow sling, observe its ratings instead of those for the underlift. Your Vulcan tow sling has a lift rating of 4,500 pounds. Do not lift anything with the tow sling that weighs more than 4,500 pounds on the end you are lifting.

OPTIONAL TOW SLING (cont'd)

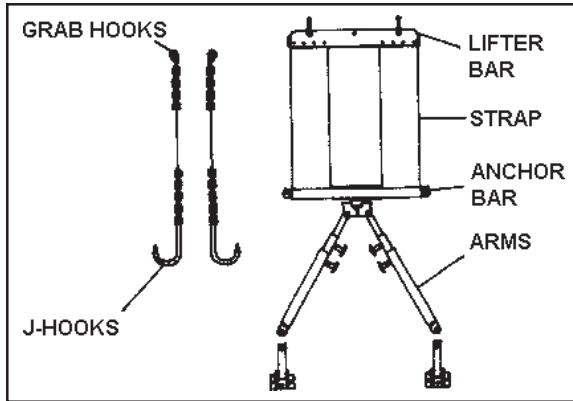

Figure 4-18.

HOOKING UP WITH THE TOW SLING

1. Set the parking brake on the disabled vehicle or use wheel chocks to prevent it from rolling free during hookup.
2. Raise the wrecker boom to about cab height of the tow truck. Lower the anchor bar of the tow sling to about bumper height of the disabled vehicle.
3. Back the tow truck, stopping with the anchor bar about 18 inches from the bumper of the disabled vehicle. Apply the tow truck's parking brakes.
4. Unlock the tow sling spacer bar extensions.
5. Let out the winch cable until the anchor bar rests on the ground and the sling straps are slackened.

HOOKING UP WITH THE TOW SLING (cont'd)

6. Extend the spacer bars until the anchor reaches under a member capable of supporting the weight of the vehicle without damage.
7. Attach a tow chain under each side of the vehicle to be towed.



WHEN USING "J" HOOKS, MAKE SURE THE LOAD IS APPLIED TO THE THROAT OR BEND. LOADS APPLIED TO THE TIP CAN CAUSE THE "J" HOOK TO FAIL, THEREBY RELEASING THE VEHICLE FROM THE TOW SLING, RESULTING IN AN ACCIDENT WITH SERIOUS INJURIES OR DEATH.

8. Pull each chain tight and secure it in the grab hook on the anchor bar. Make sure the chains are fully seated in the grab hooks. If the shanks of the "J" hooks are too long, use the grab hooks on the other ends of the chains.
9. Attach the free end of each chain to a grab hook on the lifter bar. Leave only a slight amount of slack. This is a safety precaution to insure that the chains will support the load in case the straps fail.
10. Set the spacer bar locks so that the extensions will automatically lock when retracted.

HOOKING UP WITH THE TOW SLING (cont'd)

11. Retract the winch cable until most of the slack is removed from the sling straps. Make sure the anchor bar is properly positioned. Make sure the chains do not contact fragile parts. Reposition the anchor bar and chains if necessary.
12. Place the transmission in NEUTRAL. Do that even if the drive wheels are raised to allow the wheels to spin should they contact the ground.
13. Release the parking brakes of the disabled vehicle.
14. Secure the steering wheel with the wheels straight. Use an approved steering wheel lock device. Do not rely on the vehicle's built in steering column lock. Do this even when the steering wheels are raised to reduce the hazard to other traffic should the vehicle break free from the tow sling.
15. Retract the winch cable until the tires of the disabled vehicle clear the ground at least 6 inches. Make sure the rear of the vehicle does not contact the ground or an obstruction. Make sure the spacer bar extensions are retracted and locked.



DO NOT RAISE THE ANCHOR BAR HIGHER THAN THE TOW SLING'S MOUNTING BRACKETS. OTHERWISE, A SUDDEN STOP COULD CAUSE THE TOWED VEHICLE TO PIVOT OVER THE SPACER BARS AND CRASH INTO THE BACK OF THE TOW TRUCK.

16. Attach the safety chains. Place safety stands under the vehicle or block it to keep it from falling accidentally before getting under it to attach the safety chains.



FAILURE TO USE SAFETY CHAINS COULD ALLOW THE VEHICLE TO COME FREE OF THE TOW TRUCK AND CAUSE A SERIOUS ACCIDENT.

17. Remove the safety stands or blocks. Check the trailing end of the towed vehicle for adequate ground clearance. Use a towing dolly to provide adequate ground clearance if necessary.

TOWING A VEHICLE

Always drive with extra caution while towing. Remember, you have less stopping ability and steering control when towing.

Allow greater distances between you and other vehicles when passing or changing lanes because of your extra length with the towed vehicle.

Be sure to use lights on the towed vehicle as required by state and local regulations and ordinances. Use auxiliary towing lights on the trailing end of the towed vehicle. Never use the headlights of the towed vehicle.

Federal, state, and municipal regulations require the use of safety chains when towing. Safety chains can prevent accidents. Failure to use them can cause serious accidents with bodily injuries or death. Use them for all towing, short distance and long distance.

When towing a vehicle, make sure the wheels remaining on the road are free from damage.

When towing a vehicle from the rear be sure to secure the front wheels straight. Do not rely on the vehicle's built in steering lock. Use an approved steering wheel lock instead. (See Figure 4-19.)

TOWING A VEHICLE (cont'd)

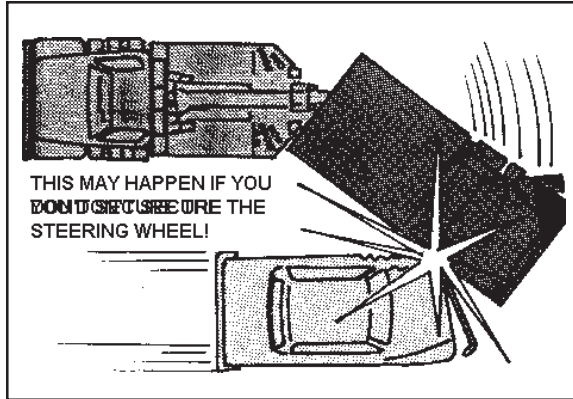

Figure 4-19.

Always consult the towing information for the disabled vehicle before hooking up for a tow.

Always follow the towing recommendations of the vehicle manufacturer regarding speed and distance to avoid damage to transmissions and drive lines. If necessary, disconnect the vehicle's drive shaft or use a dolly to support the vehicle's drive wheels.

Tow only on solid, level surfaces. Your equipment is not designed to tow off-road. Towing through mud or over rough terrain can damage your equipment or the vehicle in tow.

Never allow anyone to ride in a vehicle while it is being towed.



IF YOU MUST GET UNDER A RAISED VEHICLE FOR ANY REASON, MAKE SURE IT IS SUPPORTED BY JACK STANDS RATED FOR THE LOAD IMPOSED BY THE VEHICLE. FAILURE TO TAKE THIS PRECAUTION COULD RESULT IN SERIOUS INJURY OR DEATH.

TOWING A VEHICLE (cont'd)

Avoid jack-knifing the towed vehicle while maneuvering it into a parking space. Jack-knifing can damage your towing equipment making it unsafe for continued use.

POINTS TO CHECK WHEN POSITIONING A VEHICLE FOR TOWING

- * Raise the tires at least eight inches above the ground.
- * Raise the tires at least eight inches above the ground.
- * Make sure the trailing end of the vehicle does not drag the ground.
- * Make sure there is enough clearance to prevent the towed vehicle from contacting the tow truck when making turns.
- * Position the towed vehicle forward as much as possible for better weight distribution while maintaining the conditions listed above.
- * Check for adequate slack in safety chains to prevent them from lightening when making turns.

RECOVERY

By following the instructions presented here you reduce the possibility of a serious accident.

Recovery usually involves getting a wrecked or stuck vehicle onto a roadway and into position where it can be towed. It may be overturned, stuck in the mud, in a ditch, or off the side of a hill.

Recovery involves pulling and lifting. The boom and winches are well-suited for that, within their limits.

Although pulling and lifting sounds simple, there are many things that can go wrong. Vehicles weigh thousands of pounds. Powerful forces are required to move them. Hazards abound.

Some hazards can be predicted. Others can not. Operating safely requires a clear mind and a very high degree of alertness. You should try to anticipate what could go wrong with every move you make.

CHECKING OUT THE SCENE

You should start your recovery by checking out the scene. Check for spilled gasoline, acid or other hazardous materials. Check the position and condition of each vehicle you are to recover.

Check the contents of the vehicles and estimate their weights. Choose a recovery path. Estimate the amount of pull your winches will have to exert to reel in the vehicle.

Remember, the amount of pull needed depends on the weight of the vehicle, whether its wheels roll, and the slope and type of surface it must cross.

CHECKING OUT THE SCENE (cont'd)

Accordingly, a vehicle that weighs 10,000 pounds may require a pulling force as low as 2,000 pounds or as high as 28,000 pounds.

Ask authorities to keep traffic and bystanders clear of your work area. Do not start recovery until all accident victims are out of the area unless authorities specifically direct you to do so.

POSITIONING AND STABILIZING YOUR TOW TRUCK

Position your tow truck so that the truck faces the direction of pull. When the winch cable is used it should be in line with the boom. This will help avoid side loads on the boom. (See Figure 4-20.)

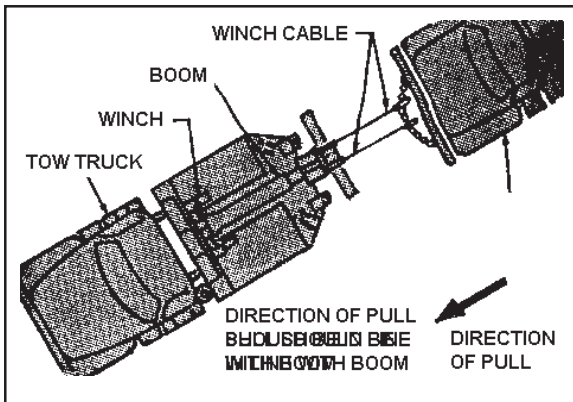

Figure 4-20.

Keep your truck on the pavement or firm ground if possible. To stabilize your truck for very light pulls apply the parking brakes and place a 4" x 4" wood chock behind each rear wheel.

To stabilize your truck for heavier pulls, use scotch blocks under the rear wheels and apply the parking brakes.

POSITIONING AND STABILIZING YOUR TOW TRUCK (cont'd)

For unusually heavy pulls, use a tree or some other anchor point to share the load. That way you can reduce pull on the truck. Using anchor points requires the use of snatch blocks (See Figure 4-21.)

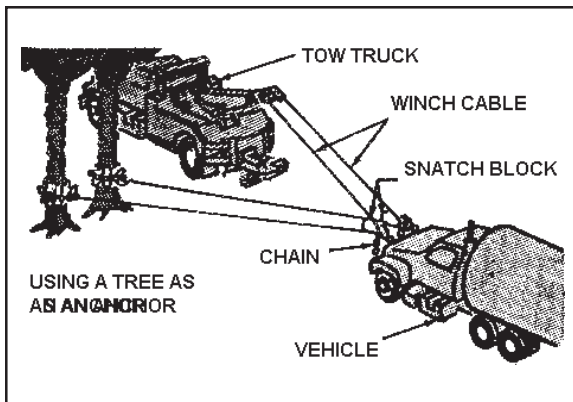

Figure 4-21.



DO NOT USE THE UNDERLIFT STINGER AND CROSS BAR TO ANCHOR THE WRECKER FOR RECOVERY. OTHERWISE, YOU MAY CAUSE EXTENSIVE DAMAGE TO THE STINGER AND OTHER PARTS OF THESE UNITS.

RIGGING WINCH CABLES

Before rigging, make sure the vehicle's ignition is OFF. If flammable materials are present, cautiously disconnect the vehicle's battery. Keep lighted flares, cigarettes, and other sources of ignition away from the area.

Do not attach winch cables directly to the vehicle. Instead, attach recovery chains to the vehicle and attach the hooks of the winch cable to the chains.

RIGGING WINCH CABLES (cont'd)

Attach hooks so that their tips are up. That way, if a hook accidentally pulls loose, it should fly towards the ground with less chance of injuring someone. Make sure that there is always at least 5 wraps of cable on the winch drum. Otherwise, the cable could pull loose from the drum.

If the estimated pull is less than the working limit for your cable (see ratings section of this manual for cable working limit) then you can attach the cable from one winch to the load. If the estimated pull is greater than the working limit for one cable, then you must use a second winch cable or snatch blocks or both. (See Figure 4-22.)

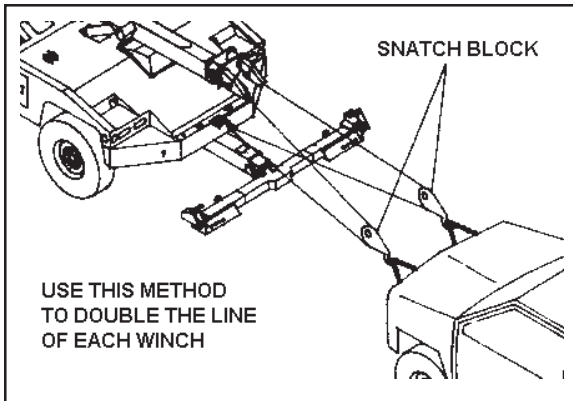

Figure 4-22.

WINCHING THE LOAD

Operate the winches to take the slack out of the cables. Before starting the pull, recheck the rigging.

Make sure no one is close enough to be injured by flying parts if a cable breaks or if the vehicle breaks free and rolls out of control.

WINCHING THE LOAD (cont'd)

Operate the winch controls on the side of the truck that gives you the most protection. Choose the side that might shield you from flying parts in case the cable breaks. Do not stand between your truck and the vehicle you are recovering. Do not stand behind the rear of your truck where you could be run over if the brakes on your truck fail. (See Figure 4-23.)

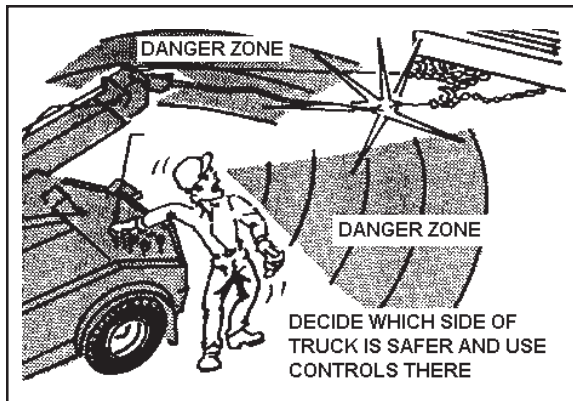

Figure 4-23.

Operate the winches to begin the pull. Constantly scan everything within your view. While winching make sure:

- * Your truck remains stable.
- * Winch cables wind evenly on the drums.
- * Cables do not become tangled.
- * Snatch blocks stay aligned with the load.
- * No one has moved into the danger area.
- * The vehicle continues to move smoothly without encountering any obstacles.

WINCHING THE LOAD (cont'd)

If the vehicle stops moving while you continue to wind in cable, stop and investigate. A cable may have come loose or something may have broken.

Also be alert for sounds that may indicate trouble. A sharp popping sound from the winch or cable may indicate the winch cable or some other part is about to break. Stop and investigate. But be careful not to get in the path of danger from whatever may be happening.

You should also listen for sounds produced by the hydraulic relief valves of the hydraulic system. The relief valves usually make no noticeable sound when winching loads within the capacity of the winch. However, if a winch quits pulling and you can hear sounds from its relief valve, the winch may be overloaded.

You may need to re-rig your winch cables if you detect overloading. Use snatch blocks in the winch line to connect additional line parts to the vehicle.

Be especially wary when winching vehicles stuck in mud. Mud may create suction that can not be easily overcome by the winches. It is best to tighten the winch cables and let just that tension, helped by the truck springs, do the work. It may take several minutes for it to produce any results. And it may be necessary to repeat the process several times.

Also be wary when winching vehicles stuck in frozen ground. If the ground froze after the vehicle got stuck, you will probably have to thaw the ground before it can be freed. Attempting to winch a vehicle from frozen ground is likely to be fruitless and cause damage.

USING THE BOOM IN RECOVERY

Winch cables are routed around sheaves mounted on the end of the recovery boom. This arrangement enables the winch to pull from the end of the boom.

Also, this enables the winch cable to lift as well as pull, an important advantage often needed in recovery. (See Figure 4-24.)

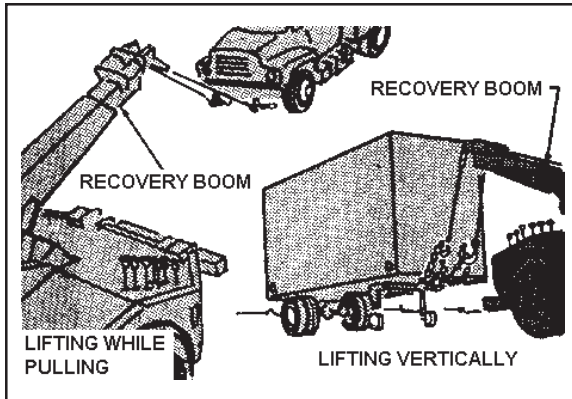

Figure 4-24.

Lift from an even higher point is possible when the boom is extended. You can lift loads vertically, completely free of the ground. When you extend the boom for recovery work, take special care to avoid side loads.

In recovery, the boom provides less lift for vehicles further from the tow truck than for ones closer. But the lift increases as the vehicle is pulled closer. Lift helps a vehicle being winched in to cross over uneven ground, rocks or other obstacles in its path.

USING THE BOOM IN RECOVERY (cont'd)

If you lower the boom during a recovery, some weight will be restored to the front end of the truck. Likewise, retracting the boom will restore some weight to the front end. Never tie down the front of your truck to keep it down. Otherwise, you may cause extensive damage to the truck frame or to the boom. (See Figure 4-25.)

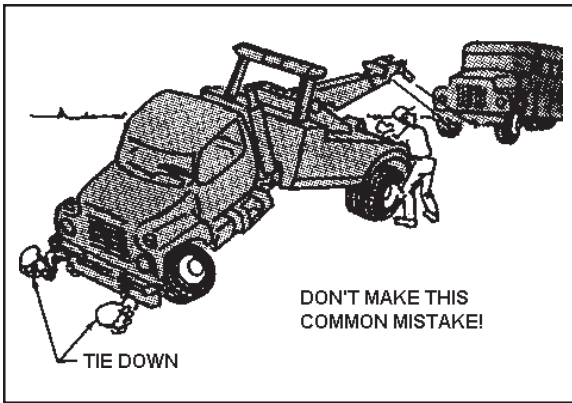

Figure 4-25.

SAFE STEERING LOAD, GVWR, GAWR, & GCWR

CHASSIS LIMITATIONS

Safe operation of your equipment is limited not only by the ratings of your equipment, but also by the amount of weight remaining on the front axle when towing and by your chassis ratings.

When towing a vehicle it is important that you:

1. Maintain at least 50% of the original weight on your front axle for steering. 50% is generally accepted by the towing industry as the amount of original front axle weight that should be maintained on the front axle for safe steering under good towing conditions on paved surfaces. More than 50% of the original front axle weight should be maintained on the front axle when towing on gravel roads, wet surfaces, snow or other adverse towing conditions.

Furthermore, information may be available from your chassis manufacturer that tells you to maintain a specific amount of weight on the front axle of your chassis for safe steering. If the chassis manufacturer recommends that you should maintain more weight on your front axle than safe steering formula indicates, then you should adhere to the manufacturer's recommendation.

2. Do not exceed the GVWR (Gross Vehicle Weight Rating) of your chassis when you are towing a load. Exceeding the GVWR of your chassis can affect its braking and handling.
3. Do not exceed the GAWR (Gross Axle Weight Rating) of your truck.

CHASSIS LIMITATIONS (cont'd)

4. Do not exceed the GCWR (Gross Combination Weight Rating) of your truck. Exceeding the GCWR can affect braking and handling of your chassis.

CALCULATING SAFE STEERING LOAD

When you obtain a tow truck, you should calculate its maximum load for safe steering. If it has more than one towing device installed, you should make the calculation for each device. You should record that information on a sticker and put it in the cab within easy view of the driver/operator. All drivers should be required to observe the limits shown on the sticker. Decals for this purpose are available from Vulcan.

The maximum towing load for safe steering is the maximum load that can be lifted without making the tow truck's steering traction unreliable and dangerous. It should be calculated after all equipment is mounted.

Weight on the steering wheels should NOT be reduced to less than one-half of their unladen weight.

A simple formula for calculating the maximum lifted load for safe steering is shown below. It is based on the requirement for maintaining one-half the unladen steering weight.

This formula has been used by the towing industry for many years and has proven reliable for determining the maximum lifted load for safe steering under good towing conditions as stated above.

CALCULATING SAFE STEERING LOAD (cont'd)

$$ML = 1/2 FAW \times WB / OH$$

Where:

AL = maximum lifted load for safe steering.

FAW = the unladen (unloaded) weight at the front axle.

WB = wheel base (distance between the center of the front axle and the center of the rear axle(s))

OH = overhang (distance from the center of the rear axle(s) to the lift point of the towing device).

To use the formula, divide the unladen weight at the front axle by two. Multiply the result by the wheel base. Then divide that result by the overhang. The last number you get is the maximum lifted load for safe steering.

Use the step by step instructions that follow to calculate safe steering tow loads for various types of towing devices. Do the calculations for each type of towing device installed on your tow truck.

Use this procedure to calculate the maximum tow load when using a wheel lift, under lift, towing sling, tow bar, or truck hitch. Use this procedure only for those devices mounted on a tow truck.

Calculations for car carriers are not covered in this manual. They require additional calculations because vehicles may be carried on their beds.

CALCULATING SAFE STEERING LOAD (cont'd)

You can use pounds and inches or centimeters and kilograms in your calculations. If you use kilograms instead of pounds and centimeters instead of inches. The safe steering limits will be in kilograms. Do not mix pounds and kilograms, nor inches and centimeters in the same calculation. If you use kilograms, convert the chassis ratings to kilograms before making calculations.

1. Weigh the truck at its front and rear wheels and note the weight in either pounds or kilograms. Make sure the truck has a full tank of fuel, that the driver is in the cab, and that the truck is unloaded, except for usual towing equipment. On trucks with tandem axles, include the combined weight of both rear axles. (See Figure 5-1.)

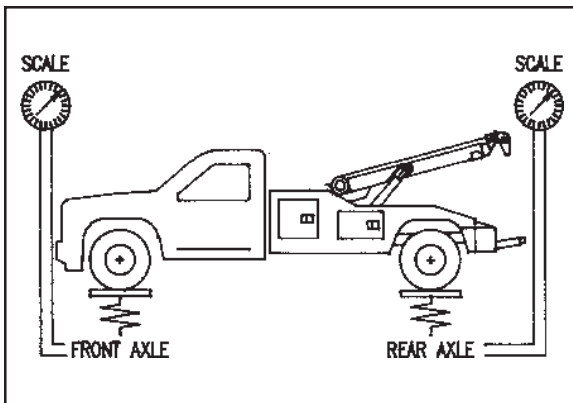

Figure 5-1.

2. Carefully measure the wheel base and note the distance in either inches or centimeters. (See Figures 5-2 & 5-3.)

CALCULATING SAFE STEERING LOAD (cont'd)

3. Measure the overhang and note the distance in either inches or centimeters.
(Refer to Figures 5-2 & 5-3.)

NOTE
THE TOWING DEVICE MUST BE IN ITS POSITION NORMALLY USED FOR TOWING! OTHERWISE, THE TOWING LIMITS WILL BE WRONG.

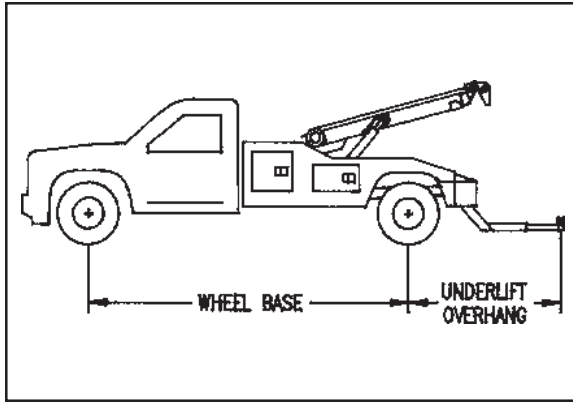

Figure 5-2.

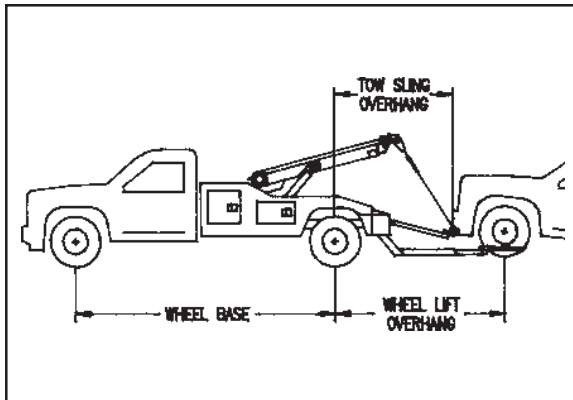

Figure 5-3.

CALCULATING SAFE STEERING LOAD (cont'd)

4. Divide the front axle weight by 2.
5. Multiply the result of step 4 by the wheel base.
6. Divide the result of step 5 by the overhang. The result is the maximum load that the truck can lift and maintain safe steering.

Example for a wheel lift:

Assume you found the following for your tow truck:
(See Figure 5-4.)

3350 pounds front axle weight
3600 pounds rear axle weight
135 inches wheel base distance
105 inches overhang distance

Now, make these calculations:

3350 divided by 2 is 1675
1675 multiplied by 135 is 226125
226125 divided by 105 is 2154

In the above example, 2154 pounds is the maximum safe steering load that should be lifted by the wheel lift at its usual towing position.

CALCULATING SAFE STEERING LOAD (cont'd)

Remember, this is the maximum load that should be lifted with the wheel lift under good towing conditions.

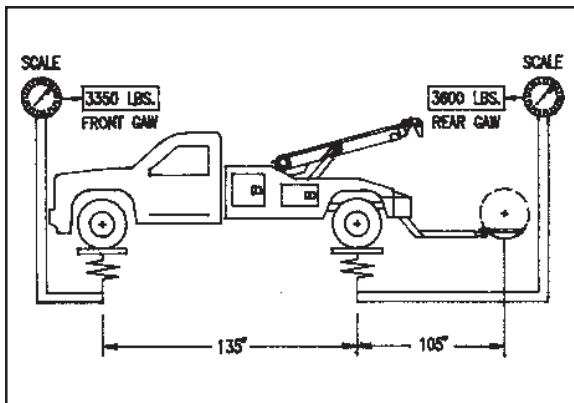

Figure 5-4

CALCULATING GAW, GVW, & GCW

For many tow trucks, the maximum load for safe steering will limit your tow load more than any other factor. The rear axle rating is usually the next most important factor. If the chassis is larger than usual, the lift rating of the towing devices is likely to be the limiting factor.

Always consider those other factors and adjust tow load limits so you will not exceed the lowest limit or rating.

For example, consider a light duty wheel lift on a Ford Super Duty chassis with an 84-inch CA. The wheel lift rating is likely to be lower than the maximum load for safe steering. If so, the wheel lift rating may be the limiting factor.

CALCULATING GAW, GVW, & GCW (cont'd)

GAWR and GVWR are often the limiting factors when tow equipment is mounted on the minimum recommended chassis. Always compute the GAW and GVW and compare them to the chassis GAWR and GVWR to see if you should reduce your tow loads to avoid exceeding those chassis ratings.

Simply add certain numbers from previous calculations to determine GAW (Gross Axle Weight) and GVW (Gross Vehicle Weight). Compare what you get with the chassis GAWR and GVWR. That will tell you if your chassis will be loaded within its ratings when towing the maximum load for safe steering.

EXAMPLE OF CALCULATING REAR AXLE GAW

This example uses numbers from the previous example to show the types of information to use:

1675	(1/2 the front axle weight)
+ 2154	(maximum load for safe steering)
+ 3600	(unloaded rear axle weight)
<hr/>	
7429	(GAW of rear axle)
	(See figure 5-5.)

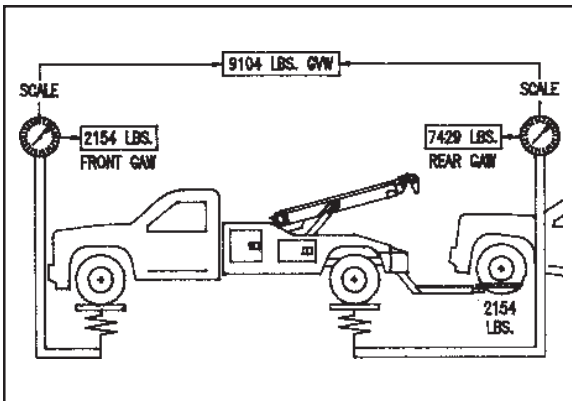

Figure 5-5.

EXAMPLE OF CALCULATING REAR AXLE GAW (cont'd)

Thus, the rear GAWR of the truck chassis used in the example should be at least 7429 pounds.

EXAMPLE OF CALCULATING GVW

This example uses numbers from the previous example to show the types of information to use:

3350	(unloaded weight of the front axle)
+ 3600	(unloaded weight of the rear axle)
+ 2154	(maximum load for safe steering)
<hr/>	
9104	(GVW)
	(Refer to figure 5-5.)

Thus, the GVWR of the truck chassis used in the example should be at least 9104 pounds.

EXAMPLE OF CALCULATING GCW

To calculate GCW, simply add the total weight of your tow truck plus the total weight of the vehicle you intend to tow.

For example, suppose you intend to tow a vehicle that weighs 4,000 pounds.

The following example uses numbers from the earlier example to show the types of information to use:

3350	(unloaded weight of the front axle)
+ 3600	(unloaded weight of the rear axle)
+ 4000	(weight of towed vehicle)
<hr/>	
10,950	(GCW)

Thus, the GCWR of the truck chassis used in the example should be at least 10,950 pounds.

EXAMPLE OF CALCULATING GCW (cont'd)

Remember, these are only examples. You must use the actual weights and dimensions of your tow truck when calculating GAW, GVW and GCW.

Weights for most vehicles that you might encounter when towing can be obtained from various trade sources and consumer report magazines. We suggest that you acquire such information to help you stay within the ratings of your equipment and chassis.

MAINTENANCE

GENERAL

Any equipment requires proper maintenance for long life and normal operation. You should always take the time to lubricate any moving parts and replace any damaged or worn parts. If you follow these guidelines your Vulcan wrecker should operate dependably, efficiently, and safely.

PRECAUTIONS

Always observe these precautions when performing routine maintenance on any hydraulic wrecker.

- * Do not disconnect any hydraulic line that could allow a component to fall or move under its own weight when the hydraulic oil is discharged. Make sure the component is properly supported first.
- * Do not place your hands near any leaking hydraulic oil that produces a stream or spray. Oil leaking in this manner could inject into you skin, resulting in serious bodily injury.
- * Never apply lubricant or perform any kind of maintenance while the wrecker is operating under power.

INSPECTION AFTER EACH USE

It is important to visually inspect your equipment after each use. Pay particular attention to the following area's:

1. Make sure the winch cable(s) show no obvious damage and that the swagged cable termination at each hook is in good condition. Cable clips are not acceptable. (See Figure 6-1.)

INSPECTION AFTER EACH USE (cont'd)

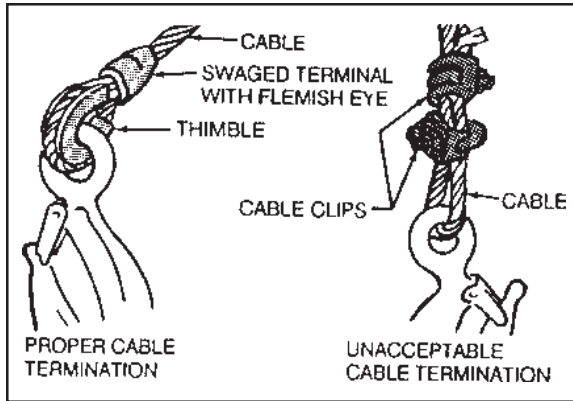

Figure 6-1

2. Sheave wheel housings should be inspected for any sign of wear, bending, or damage.
3. Carefully inspect all parts of the recovery boom and all parts of the underlift including the wheel retainer scoops and forks. Check for any bending, cracking or deformation of any parts or welds. Pay attention to paint cracking in the structure beneath.
4. Inspect all safety chains and hook up chains and hooks for bending or damage.
5. Check for loose or missing parts.

NOTE

UNLESS OTHERWISE STATED TORQUE ALL FASTENERS TO THE VALUES GIVEN IN THE TABLE IN SECTION VII

INSPECTION AFTER EACH USE (cont'd)



IF ANY DEFECT IS FOUND OR THERE IS A MISSING PART, DO NOT OPERATE THE EQUIPMENT UNTIL REPAIRS ARE MADE OR THE MISSING PART REPLACED WITH ORIGINAL VULCAN PARTS. TIGHTEN ANY LOOSE HARDWARE. DO NOT ATTEMPT TO BEND METAL BACK TO ITS ORIGINAL SHAPE OR MAKE REPAIRS BY WELDING. FAILURE TO HEED THIS WARNING COULD CAUSE EQUIPMENT FAILURE THAT LEADS TO SERIOUS INJURY OR LOSS OF LIFE.

DAILY SAFETY INSPECTION

Inspect your wrecker daily to be sure there are no conditions that would adversely affect safety. Inspect items 1 through 5 above regardless of whether the equipment has been used.

In addition, inspect the following each day:

1. Inspect all hydraulic hoses for any sign of wear or leakage.
2. Check the truck chassis including the engine compartment, vehicle under clearance, wheels, tires, lights, horns, mudflaps, windshield wipers, and transmission fluid level.
3. Inspect all pivot pins to ensure they are properly attached and not loose.
4. Inspect for any loose or missing hardware, bolts, or nuts.

DAILY SAFETY INSPECTION (cont'd)

5. Check all optional equipment and accessories for any wear or damage. Make sure all equipment is stored properly so that it will not fall off and become a hazard to other traffic.
6. Make sure the wheel grid system is locked on the crossbar.
7. Check all moving parts to make sure there is no excessive wear. Carefully inspect all parts of the recovery boom and all parts of the underlift including the wheel retainer scoops and forks. Check for any bending, cracking, or deformation of any parts or welds. Pay attention to paint cracking which may indicate a dangerous condition in the structure beneath.

NOTE

UNLESS OTHERWISE STATED, TORQUE ALL FASTENERS TO THE VALUE GIVEN IN SECTION VII.



IF ANY DEFECT IS FOUND OR THERE IS A MISSING PART, DO NOT OPERATE THE EQUIPMENT UNTIL REPAIRS ARE MADE OR THE MISSING PART REPLACED WITH ORIGINAL VULCAN PARTS. TIGHTEN ANY LOOSE HARDWARE. DO NOT ATTEMPT TO BEND METAL BACK TO ITS ORIGINAL SHAPE OR MAKE REPAIRS BY WELDING. FAILURE TO HEED THIS WARNING COULD CAUSE EQUIPMENT FAILURE THAT LEADS TO SERIOUS INJURY OR LOSS OF LIFE.

MONTHLY SERVICE

You should do a thorough safety check on your truck and equipment every month. This check should be far more thorough than you daily checks.

Check the chassis carefully. In addition to the usual chassis maintenance, check wrecker hydraulic hoses and wiring that may be in the engine compartment. Make sure that hoses are not leaking. Make sure all wiring is secure and the insulation is free from damage, especially switch panel wiring.

Make sure there are no loose parts dangling from under the chassis. Make sure wheels and tires are free from damage and excess wear. Key points to check are as follows:

1. Check the oil level of the reservoir with all cylinders fully retracted. The oil should be about two inches from the top of the reservoir filler neck. Add oil if it is lower than that.
2. Unwind the winch cables. Inspect them throughout their lengths. Make sure the cable has no damage and that the swagged cable termination at the hook is in good condition. Check the winches to make sure their mounting bolts are tight and that their parts are free from damage.
3. Check all mounting bolts to make sure they are tight and free from damage.
4. Check all structural members including the underlift wheel retainers, forks and related components. Extend the stinger to inspect it. Be sure no damaged parts or signs of impending failure are present. Look closely for hairline cracks, especially in welds. Also look for bent or distorted parts. Make sure no part is missing.

MONTHLY SERVICE (cont'd)

5. Extend the wrecker and underlift booms. Inspect sliding surfaces for excess wear. Lubricate the wear pads and sliding surfaces. Replace the wear pads when the sliding surfaces show signs of metal to metal contact.
6. Lubricate all grease fittings. See Lubrication Diagram in Section VII.
7. With the PTO disengaged, operate the control handles. Make sure they do not stick or have excessive play. Make sure they have a full range of travel when actuated.
8. Make sure the wrecker hydraulics system is free from leaks. Make sure hydraulic hoses are secure and have proper clearance from exhaust components, wheels and drive line parts. Make sure there are no kinks or worn places on hydraulic hoses.
9. Check the wrecker unit for loose or missing parts. Pay particular attention to fasteners.
10. Pull out the safety chains from their storage compartments and make sure no part of them is damaged or missing.
11. Place towing chains and chains used for recovery on the ground so you can examine all their parts. Make sure no part of them is damaged or missing.
12. Make sure that all loose equipment is properly stowed and none is missing.

NOTE

UNLESS OTHERWISE STATED, TORQUE ALL FASTENERS TO THE VALUES GIVEN IN THE TABLE IN SECTION VII.

HYDRAULIC OIL

Check the oil level in the hydraulic reservoir at least once a month. Avoid overfilling the reservoir. The oil level in the tank should be about two inches below the top of the filler neck. The air space compensates for oil in partially extended hydraulic cylinders and for expansions which occurs when the oil gets hot.

The following is a list of recommended hydraulic oils for your system. Be sure to use the proper oil for your temperature range. If you are unable to find the oils on this list, use an oil conforming to ISO Grade 46.

Ambient Temperature
Range:
Above 0 Degrees F.

Ambient Temperature
Range:
-20 to 100 Degrees

Exxon Nuto H 46
Amoco AW 46
Arco Duro AWS-215
Chevron AW-46
Citgo AW-46
Mobil DTE 25
Sun Sunvis 8821 WR
Conoco AW-46 Super

Exxon Univis N 46
Amoco Rycon 46
Citgo AW-46 All Temp
Mobil DTE 15
Shell Tellus T 46
Texaco Rando HD AZ 46
Shell Tellus 46
Texaco Rando Oil HD 46

Make sure the hydraulic oil remains clean and free of contamination at all times. Contaminated oil shows signs of turning black when over heated or filled with suspended dirt particles. Oil polluted with water becomes milky in appearance.

During very cold winters, it may become necessary to change to a lighter weight.

OIL FILTER

Replace the oil filter after the first month of service or the first thirty hours, whichever comes first. Replace the filter every six months after the first change, Use a filter that is the exact same type as the one furnished.

Always follow the applicable local, state, and federal guidelines when disposing of used oil.

LUBRICATION

Lubricate the wrecker at least once a month. Lubricate the underlift pivot at least once a week.

Use the Lithium EP multipurpose grease, NLGI Grade 2, containing three to five percent molybdenum disulfide. It is important to use this type of grease when lubricating the underlift pivot pin. The following brands conform to the proceeding specifications:

- * Exxon Beacon Q-2
- * Texaco MolyTex EP-2
- * Chevron Moly-2
- * Amoco Moly-Lith

OIL

Use motor oil to lubricate moving joints that do not have grease fittings.

CABLE LUBRICANT

Lubricate the winch cables with a lubricant made specifically for wire rope. Do not use motor oil. Wire rope lubricants have specific design qualities. These lubricants penetrate the rope braid. They are free of acids and alkalis. Wire rope lubricants have good adhesive strength. They also resist water and prevent rust.

WINCH GEAR BOX LUBRICANT

Refer to the winch manufacturer recommendations for gear box lubricants and filling procedures.

REPLACING PARTS

Use only genuine Vulcan parts. Never replace factory parts with homemade parts or unknown substitutes.

Vulcan recommends that you return you equipment to your authorized Vulcan distributor for an annual safety inspection and preventative maintenance evaluation.



ALTHOUGH VULCAN MANUFACTURES EQUIPMENT TO WITHSTAND THE RATED LOADS AND DAY TO DAY OPERATION, CERTAIN PARTS OF THE EQUIPMENT WILL WEAR OUT OVER TIME. IT IS YOUR RESPONSIBILITY TO REPLACE WORN PARTS BEFORE THEY FAIL, TO AVOID EQUIPMENT DAMAGE OR INJURY. A THOROUGH SAFETY INSPECTION WILL ALERT YOU TO PARTS NEEDING REPLACEMENT. REFER TO PAGES VI-2 THRU VI-10 OF THIS MANUAL WHEN INSPECTING YOUR UNIT.

LUBRICATION DIAGRAM

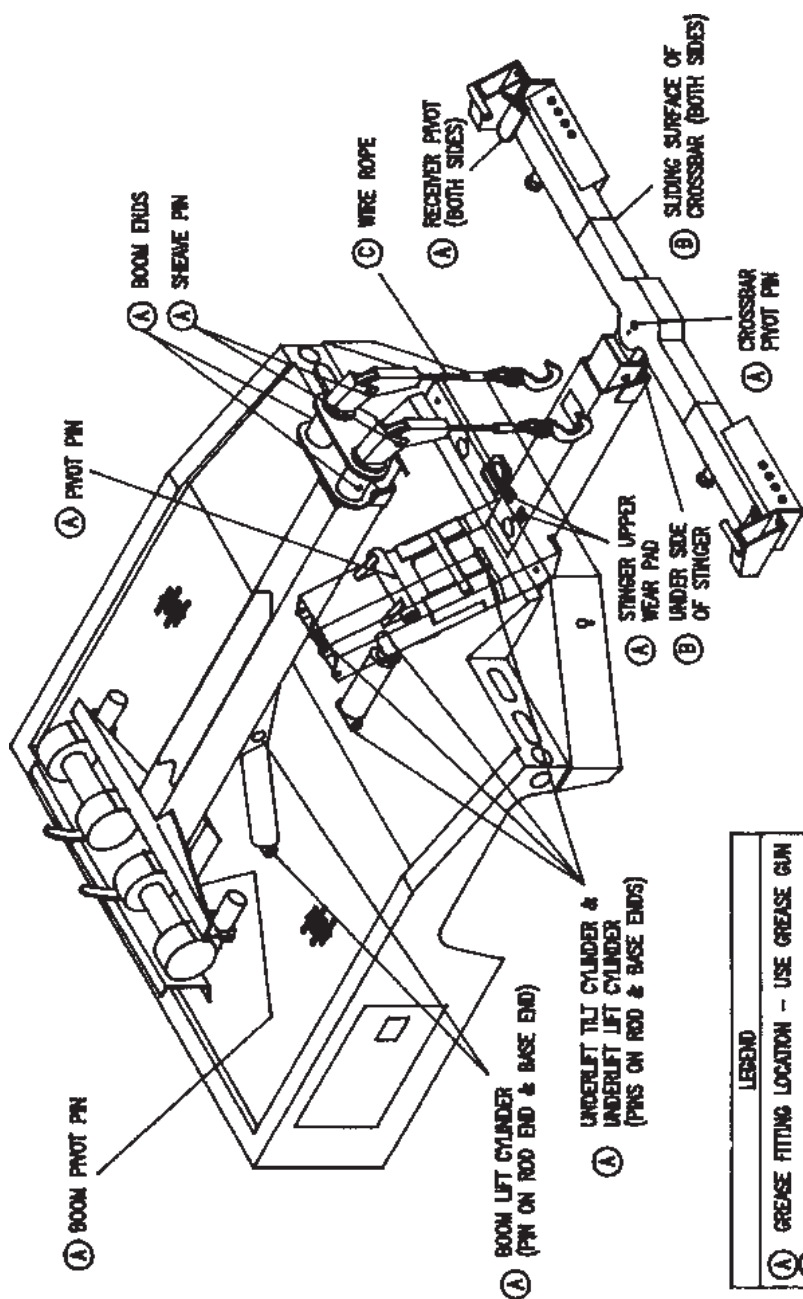

LEGEND	
(A)	GREASE FITTING LOCATION - USE GREASE GUN
(B)	APPLY GREASE MANUALLY TO SLIDING SURFACE
(C)	USE WIRE ROPE LUBRICANT

TROUBLESHOOTING

If a functional problem occurs, you should be able to correct it by replacing malfunctioning parts with new ones. Your main concern will be to determine with reasonable certainty what parts are defective. The troubleshooting section that follows should help you isolate the defective parts.



NEVER ATTEMPT TO DISCONNECT A HYDRAULIC HOSE WITHOUT FIRST BLOCKING THE EQUIPMENT SO THAT IT CAN NOT FALL.

PROBLEM: OIL GETS EXCESSIVELY HOT

Probable cause:	Remedy:
Oil level low	Fill to proper level.
Dirty oil	Drain oil reservoir, change oil and filter.
Defective pump	Replace pump.

PROBLEM: OIL FOAMY

Probable cause:	Remedy:
Air Leak in suction line	Tighten connections.
Wrong type of oil	Change oil.
Oil level low	Fill to proper level.

TROUBLESHOOTING (cont'd)

PROBLEM: ALL CONTROL FUNCTIONS SLUGGISH

Probable cause:	Remedy:
Collapsed or blocked suction hose	Repair or replace hose.
Defective pump	Operate engine speeds higher than normal. If functions improve change pump.
Oil level low	Fill to proper level.

PROBLEM: BOOM DROPS WHILE TOWING

Probable cause:	Remedy:
Improper lock valve adjustment	Adjust the lock valve.
Dirt between seat of lock valve or bad lock valve	Clean and reassemble or replace the lock valve.
Defective lift cylinder	Repair or replace the lift cylinder.

PROBLEM: BOOM WILL NOT LOWER

Probable cause:	Remedy:
Improper adjustment of lock valve	Adjust lock valve
Defective directional control valve	Repair or replace valve.

TROUBLESHOOTING (cont'd)

PROBLEM: ENGINE STALLS UNDER LOAD

Probable cause:	Remedy:
Engine speed to low	Adjust engine RPM.
Improper adjustment of relief valve	Adjust pressure to 2500 PSI.

PROBLEM: BOOM STALLS UNDER LOAD

Probable cause:	Remedy:
Improper relief valve setting	Lubricate and replace pads if necessary.

PROBLEM: UNDERLIFT WILL NOT RETRACT LOAD

Probable cause:	Remedy:
Slide pads worn or not lubricated	Lubricate and replace pads if necessary.
Low pressure setting	Set pressure to 2500 PSI.
Collapsed or blocked cylinder hoses	Repair or replace hoses as necessary.

INSTALLATION

PRELIMINARY INSTRUCTIONS

Before you go any further, check the serial plate to make sure that it is one of the models covered by this manual.

Inspect the unit to make sure it has not been damaged.

Make sure that you have received all parts and components shown on the packing list.

Make sure that you have the proper PTO for your truck chassis. We recommend a 100 percent (minimum) PTO for chassis with diesel engines and a 80% (minimum) PTO for chassis with gasoline engines.

Be careful to avoid damaging the unit when handling it with a lift truck.

INSTALLATION PROCEDURES

1. Disconnect the electrical cables from the truck battery.
2. Install the PTO and control cable according to the manufactures instructions. (See Figure 7-1.)

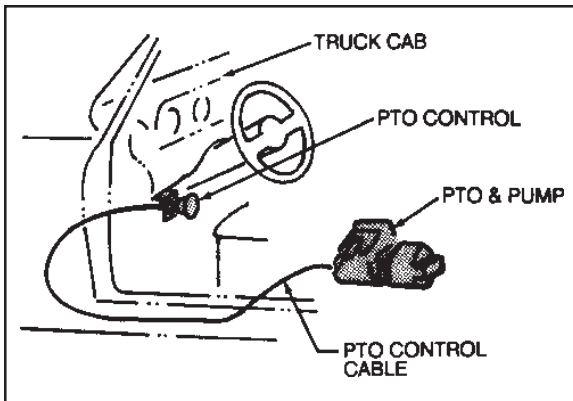

Figure 7-1.

INSTALLATION PROCEDURES

3. Install the hydraulic pump to the PTO.
4. Make sure exhaust components do not interfere with the body, mudflaps or underlift. Modify if necessary. (See Figure 7-2.)



Figure 7-2.

5. Remove all frame crossmembers, fuel tanks, tail lights, etc., aft of rear axle, that would interfere with the installation and operation of the underlift.
6. Alter the brake proportioning valve only if recommended by the chassis manufacturer. Make the changes in strict accordance with the chassis manufactures instructions. If you have questions about the brake proportioning valve, please contact the chassis manufacturer or dealer. (See Figure 7-3.)

INSTALLATION PROCEDURES (cont'd)

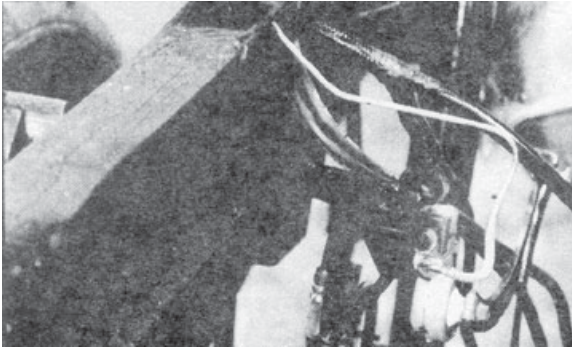

Figure 7-3.

NOTE

NORMALLY, THE BRAKE PROPORTIONING VALVE INCREASES THE BRAKING POWER OF THE REAR BRAKES WHEN A LOAD DEPRESSES THE REAR SUSPENSION. HOWEVER, OVERLOAD SPRINGS REDUCE THE DEPRESSION AND MAY DEFEAT THE EFFECTS OF THE PROPORTIONING.

7. Cut off the truck frame rails 36 inches behind the centerline of the rear axle. Discard the pieces you cut off. (See Figure 7-4.)

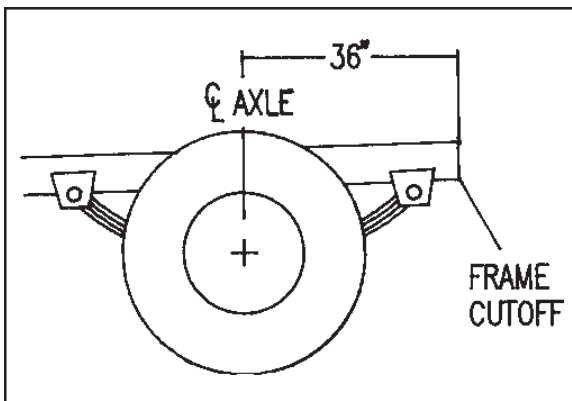

Figure 7-4.

INSTALLATION PROCEDURES (cont'd)

8. Make sure there is no interference with fuel lines, fuel tanks or brake lines. Make sure that there will not be any interferences when the unit is loaded. Do not modify or reposition fuel tanks. Always follow chassis manufactures guidelines concerning fuel tanks.
9. Trim any bolts at rear as close as possible to the shackle nut. (See Figure 7-5.)

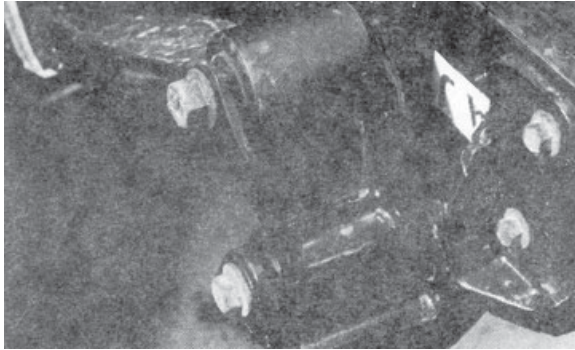

Figure 7-5.

10. Position the body on the truck frame rails. Center the body side to side.

NOTE

**SQUARE THE BODY WITH THE TRUCK FRAME RAILS. DO NOT SQUARE THE UNIT WITH THE CAB AS CABS ARE NOT ALWAYS MOUNTED SQUARE WITH THE FRAME.
(SEE FIGURE 7-6.)**

INSTALLATION PROCEDURES (cont'd)

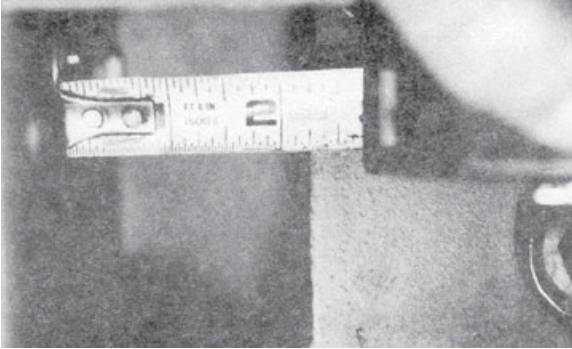

Figure 7-6.

11. Mark the front mounting plate holes. Use four holes per side. Space between the mounting brackets and the frame if necessary. (See Figure 7-7.)

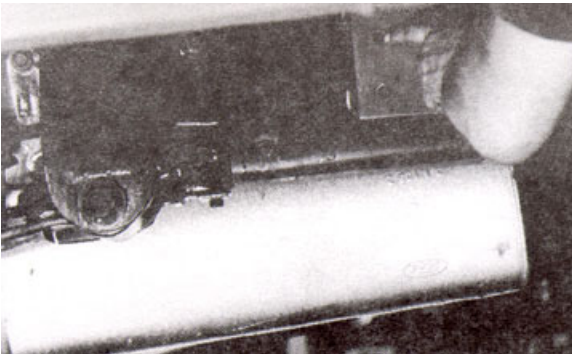

Figure 7-7.

12. Mark the two rear top-of-frame mounting holes using the tailgate mounting holes as a guide. (See Figure 7-8.)

INSTALLATION PROCEDURES (cont'd)

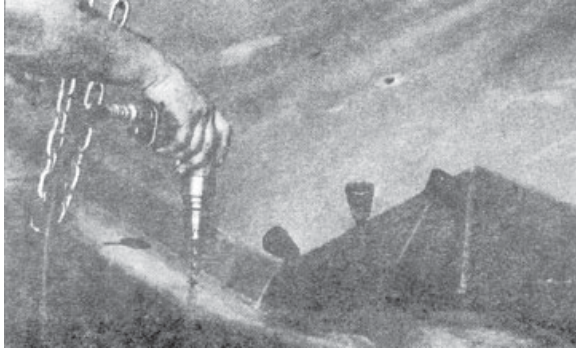

Figure 7-8.

13. Make sure that the lower frame rails are aligned and 34 inches apart. Tack the rear mounting plates to the tailgate and mark the three mounting holes on each side. (See Figure 7-9.)



Figure 7-9.

14. Remove the body from the truck chassis. Drill all mounting holes at locations previously marked.
15. Finish-weld the rear mounting plates to the tailgate.

INSTALLATION PROCEDURES (cont'd)

16. Reinstall the unit with 5/8 inch mounting bolts at front (four per side), 1/2 inch mounting bolts at top of tailgate (one per side), and 1/2 inch bolts at tailgate mounting bracket (at least two per side).
17. Install the high pressure hose between the pump and the control valve. Install the suction line from the tank to the pump.
18. Cut hole in body for fuel tank filler neck if required. (See Figure 7-10.)

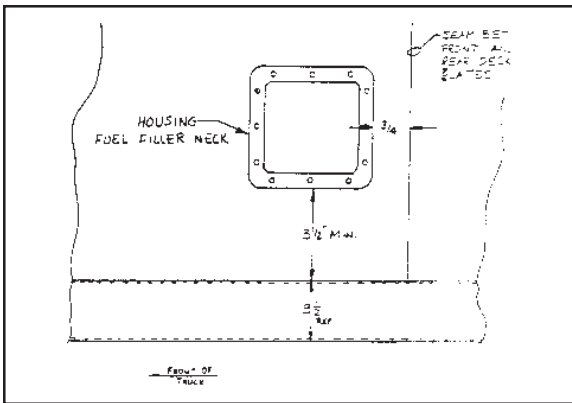

Figure 7-10.

19. Install all body lights, the magnetic light socket, and connect the chassis wiring to the wiring junction box on the wrecker body. (See Figure 7-11.)

INSTALLATION PROCEDURES (cont'd)

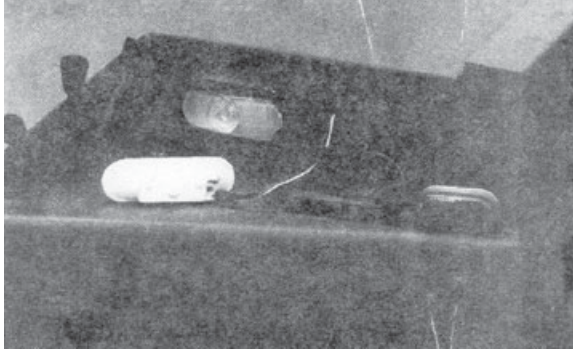

Figure 7-11.

20. Install optional remote throttle control.
21. Install all optional equipment and accessories such as light pylon, mud flaps, etc. (See Figure 7-12.)



Figure 7-12.

NOTE

WHEN TOW SLING BRACKETS ARE INSTALLED, 1/2 INCH COUNTERSUNK SCREWS MUST BE USED (INSTEAD OF 1/2 INCH HEX HD CAP SCREWS) FOR THE MOUNTING BOLTS ON TOP OF THE TAILGATE.

INSTALLATION PROCEDURES (cont'd)

23. Reconnect the trucks battery cables.
24. Fill the hydraulic reservoir with the recommended oil. The oil level should be about two inches below the top of the filler neck. See Section VI for recommended hydraulic oils.
25. Lubricate the wrecker and underlift. See section VI for recommended types of grease.
26. Check the installation of hoses and wiring. Be sure they are secure and away from exhaust components.
27. Check all newly installed fasteners for tightness. Torque all fasteners to values given on page VII-13 & VII 14.
28. Check the wrecker units control levers. Be sure they are free from sticking and return to their center positions when released.
29. Start the truck engine and set the speed to approximately 1200 to 1500 RPM using the remote throttle control.
30. To break in the pump, engage the PTO and allow it to run for ten to fifteen minutes. Make sure the pump does not cavitate and over heat. A loud rattling noise indicates cavitation. I the pump does cavitate, check for the proper hose connections at the reservoir and pump.
31. Briefly operate the controls, be sure the components move in the directions indicated by the decals.

INSTALLATION PROCEDURES (cont'd)

32. Purge air from the lift cylinders by raising and lowering the underlift and wrecker boom through several cycles. Purge air from the extension cylinders by extending and retracting the wrecker and underlift booms through several cycles. Purge air from the underlift up and down through several cycles. The wrecker and underlift should operate smoothly after purging the air.
33. Add oil to the reservoir to bring it back up to the proper level.
34. Load a vehicle on the underlift. Raise and lower the vehicle through several cycles. Extend and retract the boom through several cycles. Check for interference with fuel lines, fuel tanks, exhaust or other components.
35. Check all hydraulic connections and stop any leaks.

TIGHTENING TORQUES FOR SCREWS & NUTS

Notes:

1. All values are given in foot-pounds (ft.-lbs.)
2. When screws are used in parts with internal threads, tighten screws to torques shown for screws.
3. When nuts are used, tighten nuts to torques shown for nuts (screws or bolts should be held but not turned).

(Size 1/4"-20 - 1/2"-20)

<u>SIZE</u>	GRADE 5 ZINC PLATED (or lubricated)		GRADE 8 ZINC PLATED (or lubricated)	
	<u>SCREW</u>	<u>NUTS</u>	<u>SCREWS</u>	<u>NUTS</u>
1/4"-20 UNC	9	6	12	8
1/4"-28 UNF	10.5	7	13	10
5/16"-18 UNC	17	11	22	15
5/16"-24 UNF	18.5	13.5	24	19
3/8"-16 UNC	30.5	19.5	35	26
3/8"-24 UNF	32	24	39	33
7/16"-14 UNC	44	32	64	48
7/16"-20 UNF	48	40	70	60
1/2"-13 UNC	68	50	96	72
1/2"-20 UNF	76	64	106	90

TIGHTENING TORQUES FOR SCREWS & NUTS

Notes:

1. All values are given in foot-pounds (ft.-lbs.)
2. When screws are used in parts with internal threads, tighten screws to torques shown for screws.
3. When nuts are used, tighten nuts to torques shown for nuts (screws or bolts should be held but not turned).

(Size 1/4"-20 - 1/2"-20)

<u>SIZE</u>	GRADE 5 ZINC PLATED (or lubricated)		GRADE 8 ZINC PLATED (or lubricated)	
	<u>SCREW</u>	<u>NUTS</u>	<u>SCREWS</u>	<u>NUTS</u>
9/16"-12 UNC	100	72	128	96
9/16"-18 UNF	112	89	141	120
5/8"-11 UNC	140	102	192	144
5/8"-18 UNF	168	128	211	180
3/4"-10 UNC	240	187	330	248
3/4"-16 UNF	264	234	363	310
7/8"-9 UNC	360	255	533	400
7/14"-20 UNF	392	289	586	500
1"-8 UNC	544	340	810	608
1"-14 UNF	572	425	891	760

REPLACEMENT PARTS

FIG 1. 88040040000. 8 TON BOOM, SINGLE WINCH

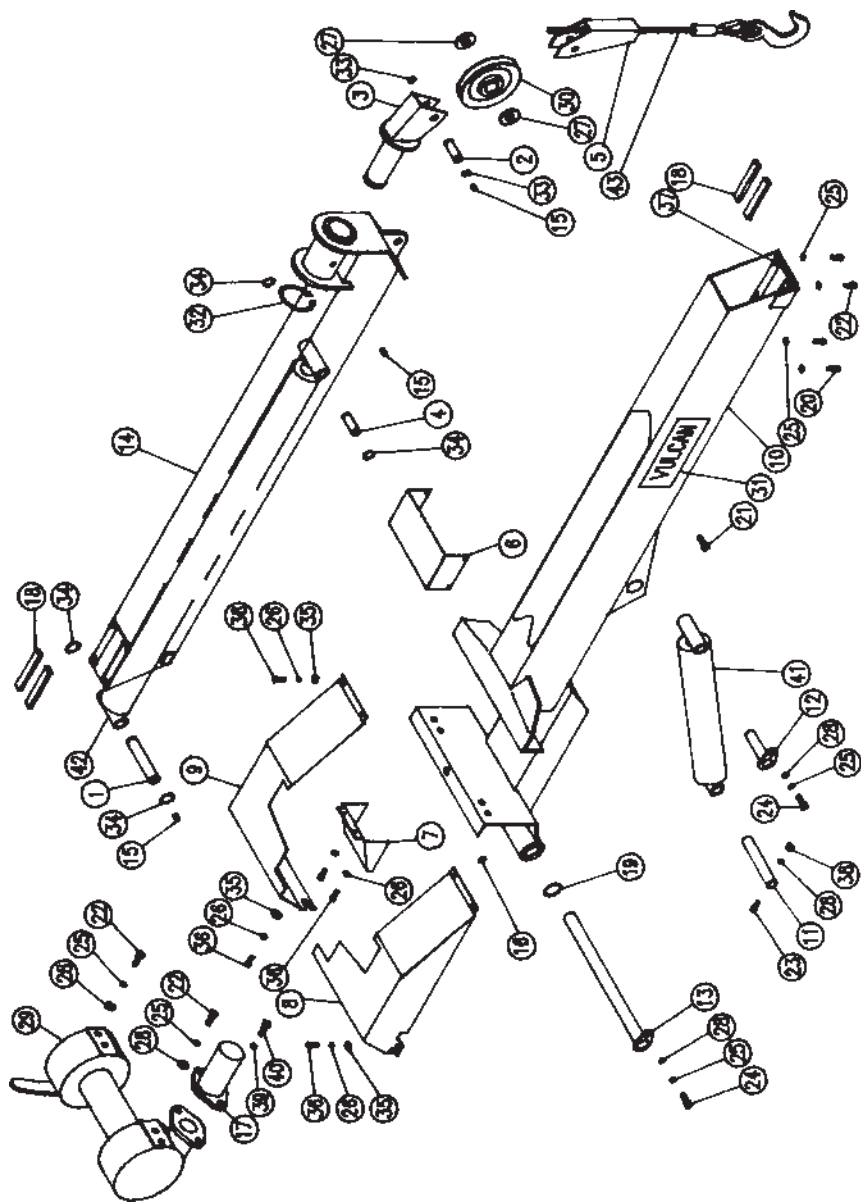

FIG 1. 880040000. 8 TON BOOM, SINGLE WINCH

ID NO	PART NO	DESCRIPTION	QTY
1	7760006	PIN, BOOM EXTEND CYLINDER (FRONT)	1
2	805180001	SHEAVE, SHAFT	1
3	804181500	SHEAVE HOUSING	1
4	851010003	PIN, EXTEND CYLINDER (REAR)	1
5	852060100	ROPE GUIDE ASSEMBLY	1
6	880042501	CHANNEL (HOSE PROTECTOR)	1
7	880090009	HOSE COVER PLATE	1
8	880091000	BOOM PIVOT COVER, LH	1
9	880098000	BOOM PIVOT COVER, RH	1
10	880240000	SINGLE WINCH, 4 TON OUTER BOOM	1
11	880400005	PIN, BOOM LOWER LIFT CYLINDER	1
12	880401500	BOOM LIFT CYLINDER, UPPER PIN	1
13	880402000	BOOM PIVOT PIN	1
14	880540000	INNER BOOM (S/SHEAVE)	1
15	9012501	1/4"-28 GREASE NIPPLE	2
16	9012532	1/8" NPT STRAIGHT GREASE NIPPLE	1
17	9016706	HYDRAULIC MOTOR	1
18	9031088	TEFLON STRIP	4
19	9056150	1-1/2" RETAINING RING	1
20	9041202	3/8" NC X 5/8" HEX HD CAP SCREW	2
21	9046572	POP RIVET	6
22	9041205	3/8" NC X 1" HEX HD CAP SCREW	8
23	9041212	3/8" NC X 2-3/4" HEX HD CAP SCREW	1
24	9041206	3/8" NC X 1-1/4" HEX HD CAP SCREW	2
25	9045051	3/8" BS LOCKWASHER, PLATED	14
26	9045055	1/4" BS LOCKWASHER, PLATED	10
27	9045215	1" BS FLAT WASHER	2
28	9045255	3/8" BS FLAT WASHER	14
29	9048136	HYDRAULIC WINCH (4 TON)	1
30	9050504	SHEAVE WHEEL	1
31	9033212	VULCAN NAME PLATE	2
32	9055215	2-3/4" EXTERNAL RETAINER RING	1
33	9056098	1" EXTERNAL RETAINER RING	2
34	9056125	1-1/4" EXTERNAL RETAINER RING	4
35	9045302	1/4" FLAT WASHER	8
36	9041005	1/4" NC X 1" HEX HD CAP SCREW	10
37	8700110	PAD RETAINING PLATE	1
38	9043306	3/8" NC HEX NUT (NYLOK)	1
39	9045059	1/2" BS LOCKWASHER	2
40	9041402	1/2" NC X 1-1/4" HEX HD CAP SCREW	2
41	880660000	LIFT CYLINDER (BOOM)	1
42	880680000	EXTENSION CYLINDER (BOOM)	1
43	9048005	CABLE, 3/8" DIA. W/HOOK	1

FIG 2. 880041000. 8 TON BOOM, DUAL WINCH

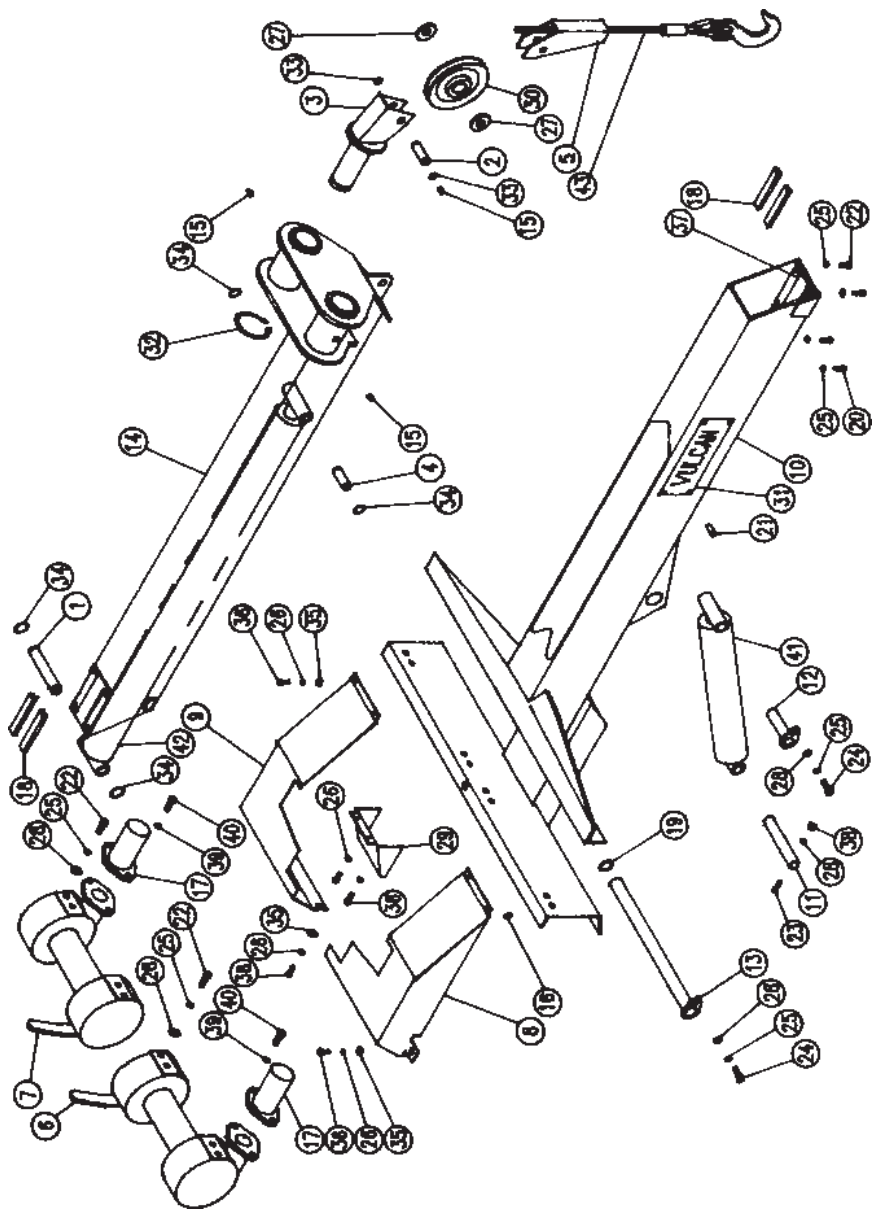

FIG 2. 880041000. 8 TON BOOM, DUAL WINCH

ID NO	PART NO	DESCRIPTION	QTY
1	7760006	PIN, BOOM EXTEND CYLINDER FRONT	1
2	805180001	SHEAVE, SHAFT	2
3	804181500	SHEAVE HOUSING	2
4	851010003	PIN, EXTEND CYLINDER REAR	1
5	852060100	ROPE GUIDE ASSEMBLY	2
6	9048136	HYDRAULIC WINCH, LH 4 TON	1
7	9048137	HYDRAULIC WINCH, RH 4 TON	1
8	880091500	BOOM PIVOT COVER, LH	1
9	880098500	BOOM PIVOT COVER, RH	1
10	880230000	D.W. 10T OUTER BOOM	1
11	880400005	PIN, BOOM LOWER LIFT CYLINDER	1
12	880401500	BOOM LIFT CYLINDER UPPER PIN	1
13	880402000	BOOM PIVOT PIN	1
14	880530000	INNER BOOM, D/SHEAVE	1
15	9012501	1-1/4"-28 GREASE NIPPLE	4
16	9012532	1/8" NPT STRAIGHT GREASE NIPPLE	1
17	9016706	HYDRAULIC MOTOR	2
18	9031088	TEFLON STRIP	4
19	9056150	1-1/2" RETAINING RING	1
20	9041202	3/8" NC X 5/8" HEX HD CAP SCREW	2
21	9046512	POP RIVET	6
22	9041205	3/8" NC X 1" HEX HD CAP SCREW	14
23	9041212	3/8" NC X 2-3/4" HEX HD CAP SCREW	1
24	9041206	3/8" NC X 1-1/4" HEX HD CAP SCREW	2
25	9045051	3/8" BS LOCKWASHER-PLATED	20
26	9045055	1/4" BS LOCKWASHER-PLATED	10
21	9045215	1" BS FLAT WASHER	4
28	9045255	3/8" BS FLAT WASHER	20
29	880090009	HOSE COVER PLATE	1
30	9050504	SHEAVE WHEEL	2
31	9033212	VULCAN NAME PLATE	2
32	9055275	2-3/4" EXTERNAL RETAINER RING	2
33	9056098	1" EXTERNAL RETAINER RING	4
34	9056125	1-1/4" EXTERNAL RETAINER RING	4
35	9045302	1/4" FLAT WASHER	8
36	9041005	1/4" NC X 1" HEX HD CAP SCREW	10
37	8100110	PAD RETAINING PLATE	1
38	9043306	3/8" NC HEX NUT NYLOK	1
39	9045059	1/2" BS LOCKWASHER	4
40	9041402	1/2" NC X 1-1/4" HEX HD CAP SCREW	4
41	880660000	LIFT CYLINDER BOOM	1
42	880680000	EXTENSION CYLINDER BOOM	1
43	9048005	CABLE, 3/8" DIA. W/HOOK	2

FIG 3. 880042000. 10 TON BOOM, SINGLE WINCH

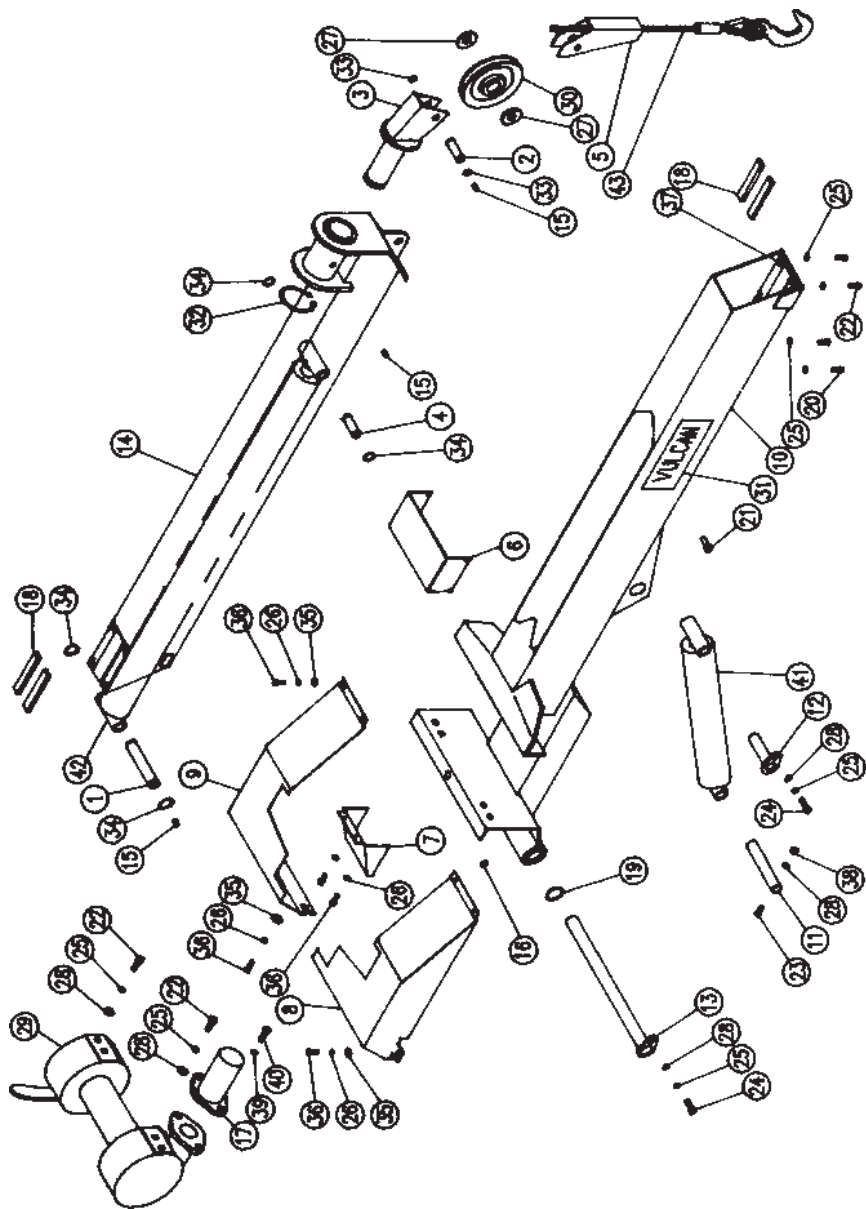
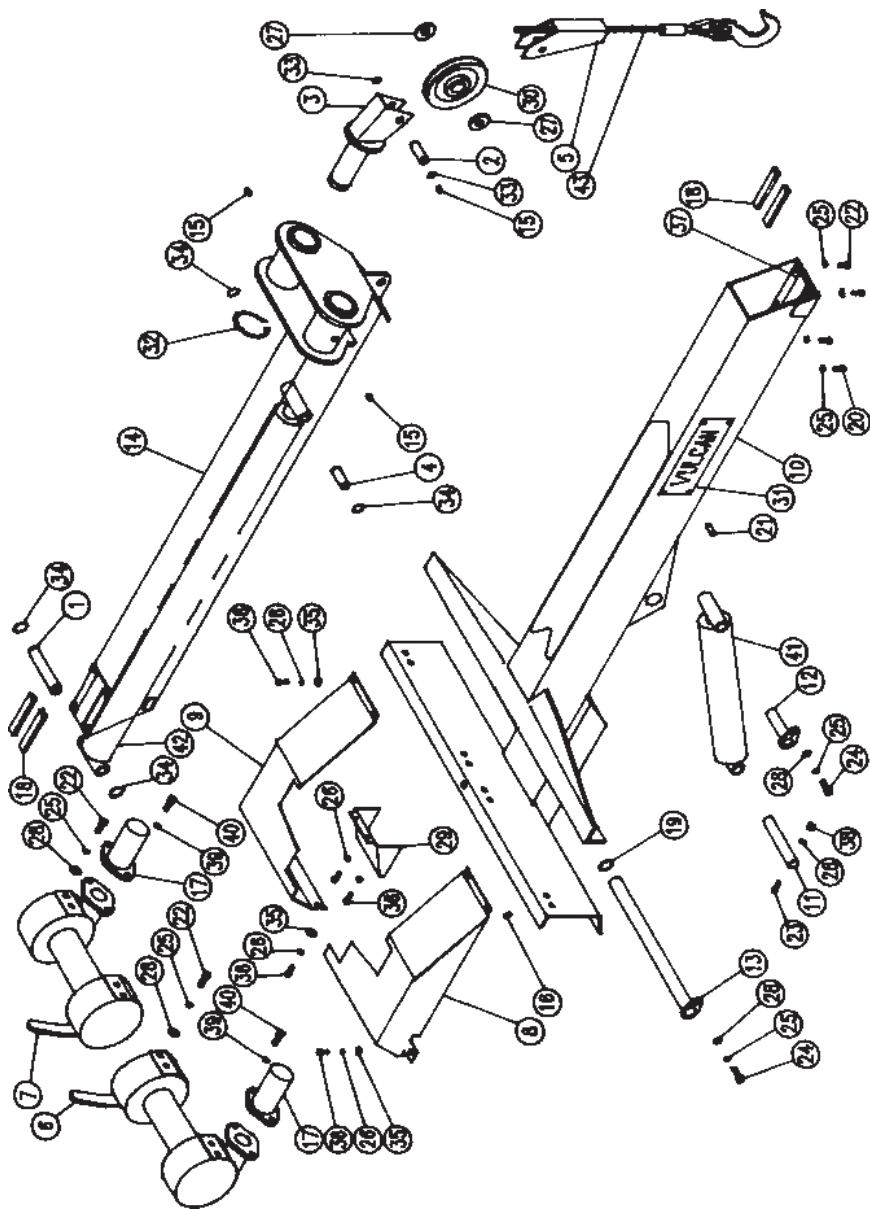

FIG 3. 880042000. 10 TON BOOM, SINGLE WINCH

ID NO	PART NO	DESCRIPTION	QTY
1	1760006	PIN, BOOM EXTEND CYLINDER FRONT	1
2	805180001	SHEAVE, SHAFT	1
3	804181500	SHEAVE HOUSING	1
4	851010003	PIN, EXTEND CYLINDER (REAR)	1
5	852060100	ROPE GUIDE ASSEMBLY	1
6	880042501	CHANNEL HOSE PROTECTOR	1
7	880090009	HOSE COVER PLATE	1
8	880091000	BOOM PIVOT COVER, LH	1
9	880098000	BOOM PIVOT COVER, RH	1
10	880200000	S.W. 10T OUTER BOOM	1
11	880400005	PIN, BOOM LOWER LIFT CYLINDER	1
12	880401500	BOOM LIFT CYLINDER. UPPER PIN	1
13	880402000	BOOM PIVOT PIN	1
14	880500000	INNER BOOM S/SHEAVE	1
15	9012501	1/4"-28 GREASE NIPPLE	2
16	9012532	1/8" NPT STRAIGHT GREASE NIPPLE	1
17	9016706	HYDRAULIC MOTOR	1
18	9031088	TEFLON STRIP	4
19	9056150	1-1/2" RETAINING RING	1
20	9041202	3/8" NC X 5/8" HEX HD CAP SCREW	2
21	9046512	POP RIVET	6
22	9041205	3/8" NC X 1" HEX HD CAP SCREW	8
23	9041212	3/8" NC X 2-3/4" HEX HD CAP SCREW	1
24	9041206	3/8" NC X 1-1/4" HEX HD CAP SCREW	2
25	9045051	3/8" BS LOCKWASHER-PLATED	14
26	9045055	1/4" BS LOCKWASHER-PLATED	14
27	9045215	1" BS FLAT WASHER	2
28	9045255	3/8" BS FLAT WASHER	10
29	9048136	HYDRAULIC WINCH 4 TON	1
30	9050504	SHEAVE WHEEL	1
31	9033212	VULCAN NAME PLATE	2
32	9055215	2-3/4" EXTERNAL RET RING	1
33	9056098	1" EXTERNAL RETAINER RING	2
34	9056125	1-1/4" EXTERNAL RETAINER RING	4
35	9045302	1/4" FLAT WASHER	8
36	9041005	1/4" NC X 1' HEX HD CAP SCREW	10
37	8100110	PAD RETAINING PLATE	1
38	9043306	3/8" NC HEX NUT NYLOK	1
39	9045059	1/2" BS LOCKWASHER	2
40	9041402	1/2" NC X 1 1/4" HEX HD CAP SCREW	2
41	880140000	LIFT CYLINDER BOOM	1
42	880680000	EXTENSION CYLINDER BOOM	1
43	9048005	CABLE, 3/8" DIA. W/HOOK	1

FIG 4. 880043000. 10 TON BOOM, DUAL WINCH
(4T)



**FIG 4. 880043000. 10 TON BOOM, DUAL WINCH
(4T)**

ID NO	PART NO	DESCRIPTION	QTY
1	7160006	PIN, BOOM EXTEND CYLINDER FRONT	1
2	805180001	SHEAVE, SHAFT	2
3	804181500	SHEAVE HOUSING	2
4	851010003	PIN, EXTEND CYLINDER (REAR)	1
5	852060100	ROPE GUIDE ASSEMBLY	2
6	9048136	HYDRAULIC WINCH, LH 4 TON	1
7	9048137	HYDRAULIC WINCH, RH 4 TON	1
8	880091500	BOOM PIVOT COVER, LH	1
9	880098500	BOOM PIVOT COVER, RH	1
10	890220000	D.W. 10T OUTER BOOM	1
11	880400005	PIN, BOOM LOWER LIFT CYLINDER	1
12	880401500	BOOM LIFT CYLINDER. UPPER PIN	1
13	880402000	BOOM PIVOT PIN	1
14	880510000	INNER BOOM (D/SHEAVE)	1
15	9012501	1/4"-28 GREASE NIPPLE	4
16	9012532	1/8" NPT STRAIGHT GREASE NIPPLE	1
17	9016706	HYDRAULIC MOTOR	2
18	9031088	TEFLON STRIP	4
19	9056150	1-1/2" RETAINING RING	2
20	9041202	3/8" NC X 5/8" HEX HD CAP SCREW	2
21	9046572	POP RIVET	6
22	9041205	3/8" NC X 1" HEX HD CAP SCREW	16
23	9041212	3/8" NC X 2-3/4" HEX HD CAP SCREW	1
24	9041206	3/8" NC X 1-1/4" HEX HD CAP SCREW	2
25	9045057	3/8" BS LOCKWASHER-PLATED	20
26	9045055	1/4" BS LOCKWASHER-PLATED	10
21	9045215	1" BS FLAT WASHER	4
28	9045255	3/8" BS FLAT WASHER	16
29	880090009	HOSE COVER PLATE	1
30	9050504	SHEAVE WHEEL	2
31	9033212	VULCAN NAME PLATE	2
32	9055275	2-3/4" EXTERNAL RETAINER RING	2
33	9056098	1" EXTERNAL RETAINER RING	4
34	9056125	1 1/4" EXTERNAL RETAINER RING	4
35	9045302	1/4" FLAT WASHER	8
36	9041005	1/4" NC X 1" HEX HD CAP SCREW	10
37	8700110	PAD RETAINING PLATE	1
38	9043306	3/8" NC HEX NUT (NYLOK)	1
39	9045059	1/2" BS LOCKWASHER	4
40	9041402	1/2" NC X 1-1/4" HEX HD CAP SCREW	4
41	880740000	LIFT CYLINDER BOOM	1
42	880680000	EXTENSION CYLINDER BOOM	1
43	9048005	CABLE, 3/8" DIA. W/HOOK	2

FIG 5. 880044000. 10 TON BOOM, DUAL WINCH
(5T)

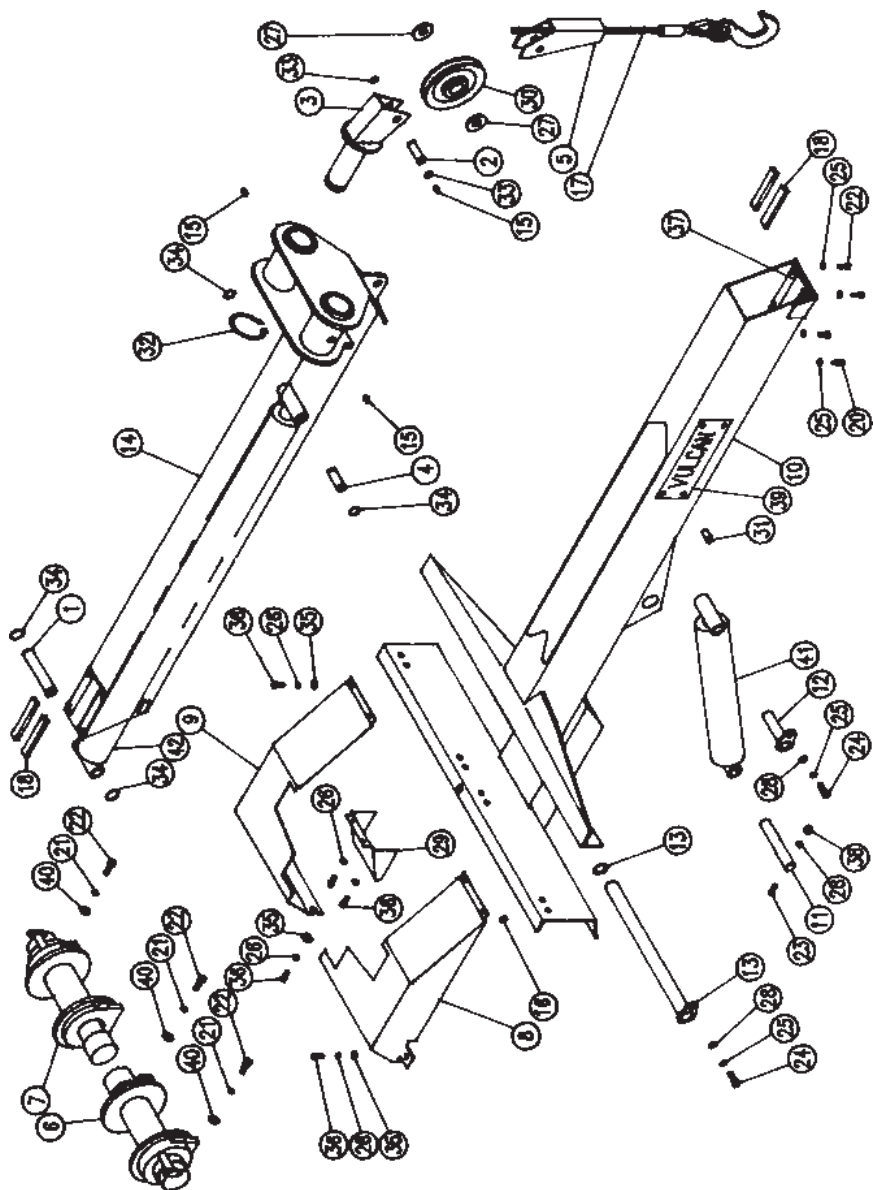

**FIG 5. 880044000. 10 TON BOOM, DUAL WINCH
(5T)**

ID NO	PART NO	DESCRIPTION	QTY
1	7760006	PIN, BOOM EXTEND CYLINDER FRONT	1
2	805180001	SHEAVE, SHAFT	2
3	804181500	SHEAVE HOUSING	2
4	851010003	PIN, EXTEND CYLINDER REAR	1
5	852060100	ROPE GUIDE ASSEMBLY	2
6	9048160	HYDRAULIC WINCH, RH 15 TON	1
7	9048161	HYDRAULIC WINCH, LH 15 TON	1
8	880091500	BOOM PIVOT COVER, LH	1
9	880098500	BOOM PIVOT COVER, RH	1
10	890210000	D.W. 10 TON OUTER BOOM	1
11	880400005	PIN, BOOM LOWER LIFT CYLINDER	1
12	880401500	BOOM LIFT CYLINDER. UPPER PIN	1
13	880402000	BOOM PIVOT PIN	1
14	880510000	INNER BOOM ID/SHEAVE	1
15	9012501	1/4"-28 GREASE NIPPLE	4
16	9012532	1/8" NPT STRAIGHT GREASE NIPPLE	1
17	9048005	CABLE, 3/8" DIA. W/HOOK	2
18	9031088	TEFLON STRIP	4
19	9056150	1-1/2" RETAINING RING	1
20	9041202	3/8" NC X 5/8" HEX HD CAP SCREW	2
21	9045058	7/16" LOCKWASHER	16
22	9041304	7/16" NC X 1-1/4" HEX HD CAP SCREW	16
23	9041212	3/8" NC X 2-3/4" HEX HD CAP SCREW	1
24	9041207	3/8" NC X 1 -1/2" HEX HD CAP SCREW	2
25	9045057	3/8" BS LOCKWASHER-PLATED	20
26	9045055	1/4" BS LOCKWASHER-PLATED	10
27	9045215	1" BS FLAT WASHER	4
28	9045255	3/8" BS FLAT WASHER	17
29	880090009	HOSE COVER PLATE	1
30	9050504	SHEAVE WHEEL	2
31	9046572	POP RIVET	6
32	9055275	2-3/4" EXTERNAL RETAINER RING	2
33	9056098	1" EXTERNAL RETAINER RING	4
34	9056125	1-1/4" EXTERNAL RETAINER RING	4
35	9045302	1/4" FLAT WASHER	8
36	904100	5-1/4" NC X 1" HEX HD CAP SCREW	10
37	8700110	PAD RETAINING PLATE	1
38	9043306	3/8" NC HEX NUT NYLOK	1
39	9033212	VULCAN NAME PLATE	2
40	9045355	7/16" FLAT WASHER	16
41	880740000	LIFT CYLINDER BOOM	1
42	880680000	EXTENSION CYLINDER BOOM	1

FIG 6. 8800700. 880 CROSSBEAM ASSEMBLY W/
WHEEL RETAINERS

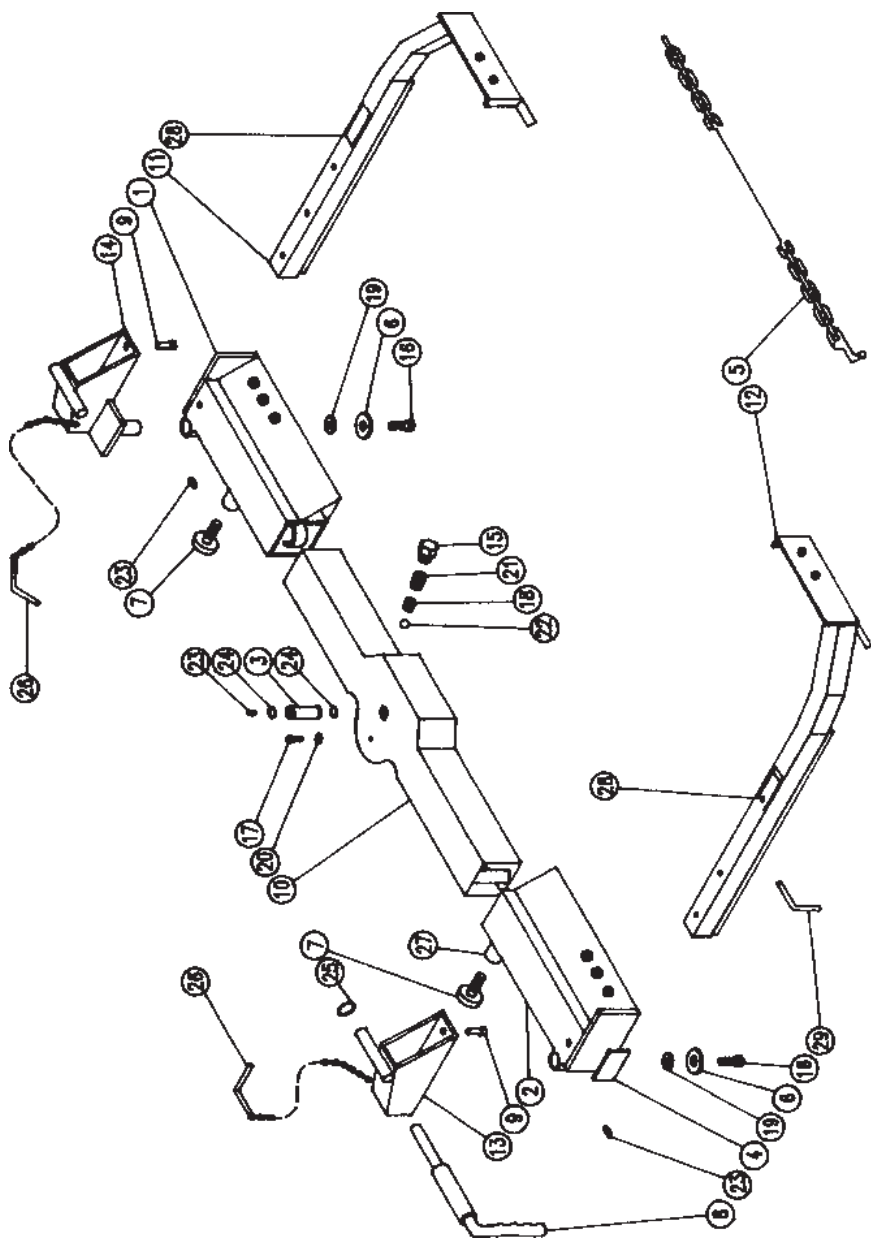

**FIG 6. 8800700. 880 CROSSBEAM ASSEMBLY W/
WHEEL RETAINERS**

ID NO	PART NO	DESCRIPTION	QTY
1	880417000	WHEEL GRID, RH	1
2	880410000	WHEEL GRID, LH	1
3	8609001	CROSSBAR PIVOT PIN	1
4	9025068	REFLECTOR	2
5	8622850	SAFETY CHAIN, 10 FT.	2
6	8600404	WASHER, 11/16" ID X 2" OD	2
7	8601900	SLIDE LOCK HANDLE KNOB ASSEMBLY	2
8	8621400	STOP PIN ASSEMBLY	2
9	8700109	SCOOP LOCK PIN	2
10	880360500	STINGER CROSSBAR	1
11	8700180	WHEEL RETAINER, RH	1
12	8700190	WHEEL RETAINER, LH	1
13	8701600	LH SCOOP BRACKET	1
14	8701500	RH SCOOP BRACKET	1
15	9012944	PIPE PLUG	1
16	9043950	5/8" NC X 1-1/2" HEX HD CAP SCREW	2
17	9043956	3/8" NC X 3/4" BUTTON HD ALLEN SCR	1
18	9045255	3/8" BS FIAT WASHER	4
19	9045354	5/8" SAE FIAT WASHER	2
20	8600406	1" OD X 3/8" ID FLAT WASHER	1
21	9047057	DIE SPRING	1
22	9052013	1" DIA. BALL BEARING	1
23	9012501	GREASE NIPPLE	3
24	9030214	O-RING	2
25	9046310	ROLL PIN HEAVY DUTY RETAINER RING	2
26	8621900	LOCK PIN W/CHAIN	2
27	8601608	SLIDE LOCK SOCKET	2
28	0033198	SAFETY CHAIN DECAL	2
29	8602001	LOCK PIN	2

FIG 7. 880050000. 880 UNDERLIFT ASSEMBLY

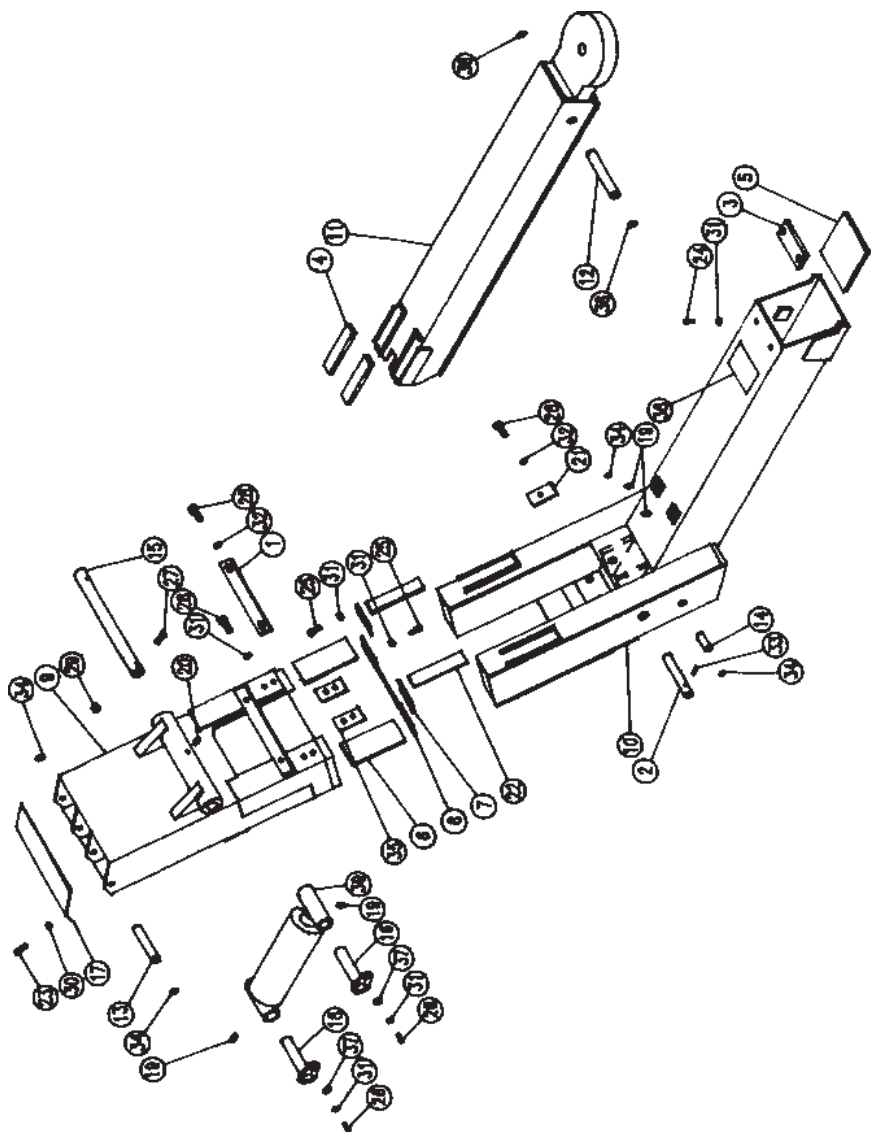
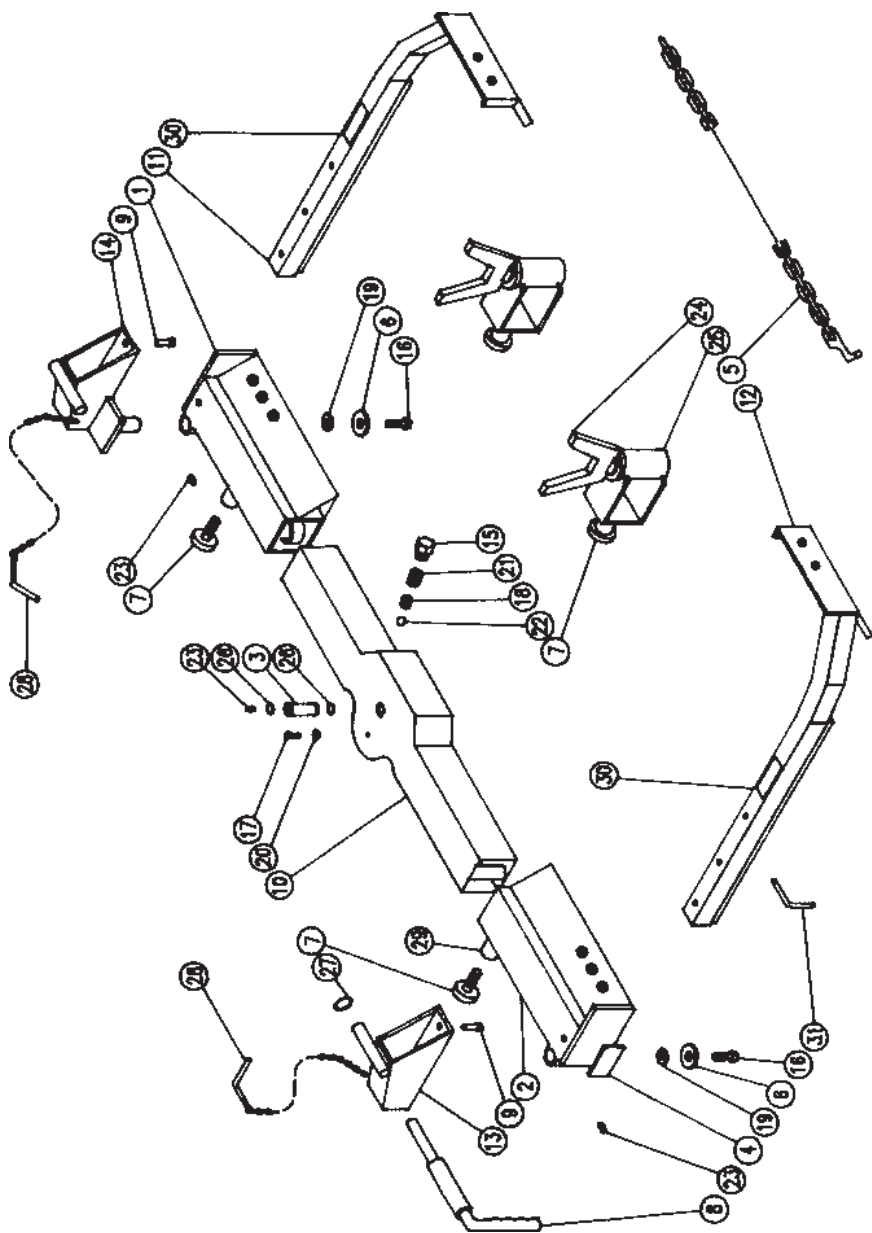

FIG 7. 880050000. 880 UNDERLIFT ASSEMBLY

ID NO	PART NO	DESCRIPTION	QTY
1	8602100	HOSE CLAMP	1
2	8600210	PIN, LIFT CYLINDER (LOWER)	1
3	880060001	SPACER BAR (STINGER)	1
4	880060002	UPPER PAD	2
5	880060003	LOWER PAD	1
6	880060004	REAR PAD	2
7	880060005	PAD HOLDER	2
8	880060007	PAD RETAINER PLATE	1
9	890250000	STINGER TILT COLUMN	1
10	880310000	OUTER BOOM	1
11	880330000	INNER BOOM	1
12	880400001	PIN, EXTEND CYLINDER, REAR	1
13	880400002	PIN, LIFT CYLINDER, UPPER	1
14	880400003	PIN, EXTEND CYLINDER, FRONT	1
15	880400004	TILT COLUMN PIVOT PIN	1
16	880400500	PIN, TILT CYLINDER, LOWER	1
17	880060006	COVER PLATE	1
18	880401000	PIN, TILT CYLINDER, UPPER	1
19	9012501	GREASE NIPPLE	4
20	9012536	GREASE NIPPLE, 1/8" NPT	1
21	8600203	HOSE CLAMP PLATE	2
22	9031158	UHMW REAR BAR	2
23	9041005	1/4" NC X 1" HEX HD CAP SCREW	2
24	9041201	3/8" NC X 1/2" HEX HD CAP SCREW	2
25	9041204	3/8" NC X 7/8" HEX HD CAP SCREW	7
26	9041205	3/8" NC X 1" HEX HD CAP SCREW	6
27	9041213	3/8" NC X 3" HEX HD CAP SCREW	1
28	9041353	7/16" NF X 3/4" HEX HD CAP SCREW	4
29	9043306	3/8" NC NYLOK HEX NUT	1
30	9045055	1/4" BS LOCK WASHER	2
31	9045057	3/8" BS LOCK WASHER	13
32	9045058	7/16" BS LOCK WASHER	4
33	9048061	HITCH PIN CLIP	1
34	9056098	1" HEAVY DUTY EXT. RETAINING RING	4
35	8600204	SPACER BAR (TILT COLUMNS)	2
36	9056125	1-1/4" HD EXT. RETAINER RING	2
37	9045255	3/8" BS FLAT WASHER	2
38	9033194	WARNING DECAL	1
39	880670000	TILT CYLINDER	1

FIG 8. 8900300. 890 CROSSBEAM ASSEMBLY W/
WHEEL RETAINERS



**FIG 8. 8900300. 890 CROSSBEAM ASSEMBLY W/
WHEEL RETAINERS**

ID NO	PART NO	DESCRIPTION	QTY
1	890407000	WHEEL GRID, RH	1
2	890400000	WHEEL GRID, LH	1
3	850020001	CROSSBAR PIVOT PIN	1
4	9025068	REFLECTOR	2
5	8622850	SAFETY CHAIN, 10 FT.	2
6	8600404	WASHER, 11/16" ID X 2" OD	2
7	8601900	SLIDE LOCK HANDLE KNOB ASSEMBLY	2
8	8621400	STOP PIN ASSEMBLY	2
9	8600405	SCOOP LOCK PIN	2
10	890360500	STINGER CROSSBAR	1
11	8500900	WHEEL RETAINER, RH	1
12	8501000	WHEEL RETAINER, LH	1
13	8501500	LH SCOOP BRACKET	1
14	8501400	RH SCOOP BRACKET	1
15	9012944	PIPE PLUG	1
16	9043950	5/8" NC X 1-1/2" HEX HD CAP SCREW	2
17	9043956	3/8" NC X 3/4" BUTON HD ALLEN SC	1
18	9045255	3/8" BS FLAT WASHER	4
19	9045354	5/8" SAE FLAT WASHER	2
20	8600406	1" OD X 3/8" ID FLAT WASHER	1
21	9047057	DIE SPRING	1
22	9052013	1" DIA. BALL BEARING	1
23	9012501	GREASE NIPPLE	3
24	850060200	FRAME FORK	2
25	850060100	FORK HOLDER	2
26	9030214	O-RING	2
27	9046310	ROLL PIN	2
28	8621900	LOCK PIN W/CHAIN	2
29	8601608	SLIDE LOCK SOCKET	2
30	9033198	SAFETY CHAIN DECAL	2
31	8602001	LOCK PIN	2

FIG 9. 890050000. 890050000. 890 UNDERLIFT
ASSEMBLY

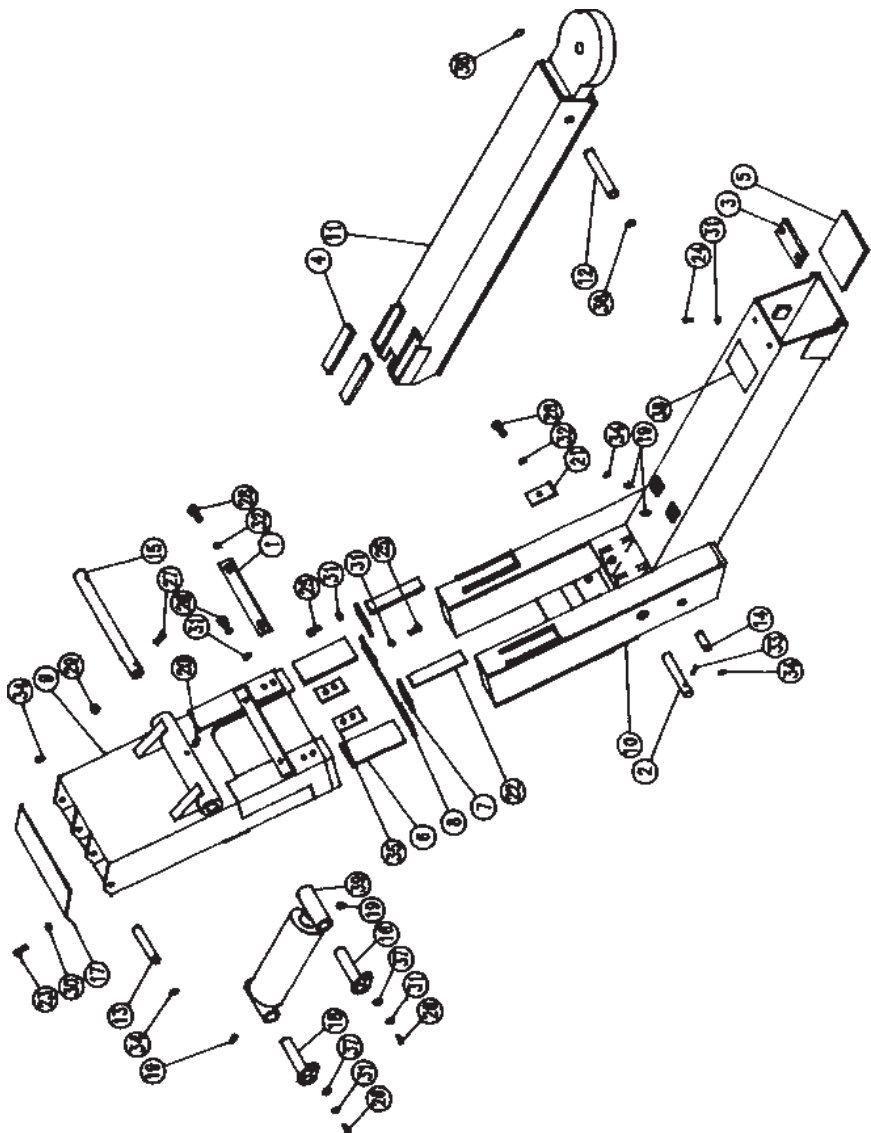

FIG 9. 890050000. 890 UNDERLIFT ASSEMBLY

ID NO	PART NO	DESCRIPTION	QTY
1	8602100	HOSE CLAMP	1
2	8600210	PIN, LIFT CYLINDER LOWER	1
3	880060001	SPACER BAR STINGER	1
4	880060002	UPPER PAD	2
5	880060003	LOWER PAD	1
6	880060004	REAR PAD	2
7	880060005	PAD HOLDER	2
8	880060007	PAD RETAINER PLATE	1
9	890250000	STINGER TILT COLUMN	1
10	890310000	OUTER BOOM	1
11	890330000	INNER BOOM	1
12	880400001	PIN, EXTEND CYLINDER, REAR	1
13	880400002	PIN, LIFT CYLINDER, UPPER	1
14	880400003	PIN, EXTEND CYLINDER, FRONT	1
15	880400004	TILT COLUMN PIVOT PIN	1
16	880400500	PIN, TILT CYLINDER, LOWER	1
17	880060006	COVER PLATE	1
18	880401000	PIN, TILT CYLINDER, UPPER	1
19	9012501	GREASE NIPPLE	2
20	9012536	GREASE NIPPLE, 1/8" NPT 90 DEG	1
21	8600203	HOSE CLAMP PLATE	2
22	9031158	UHMW REAR BAR	2
23	9041005	1/4" NC X 1" HEX HD CAP SCREW	2
24	9041201	3/8" NC X 1/2" HEX HD CAP SCREW	2
25	9041204	3/8" NC X 7/8" HEX HD CAP SCREW	7
26	9041205	3/8" NC X 1" HEX HD CAP SCREW	6
27	9041213	3/8" HC X 3" HEX HD CAP SCREW	1
28	9041353	7/16" NF X 3/4" HEX HD CAP SCREW	4
29	9043306	3/8" NC NYLOK HEX NUT	1
30	9045055	1/4" BS LOCK WASHER	2
31	9045057	3/8" 8S LOCKWASHER	13
32	9045058	7/16" BS LOCK WASHER	4
33	9048061	HITCH PIN CLIP	1
34	9056098	1" H.D. EXTEND RETAINING RING	4
35	8600204	SPACER BAR TILT COLUMNS	2
36	9056125	1-1/4" H.D. EXTEND RETAINER RING	2
37	9045255	3/8" BS FLAT WASHER	2
38	9033194	WARNING DECAL	1
39	880670000	TILT CYLINDER	1

FIG 10. 890032000. BODY ASSEMBLY

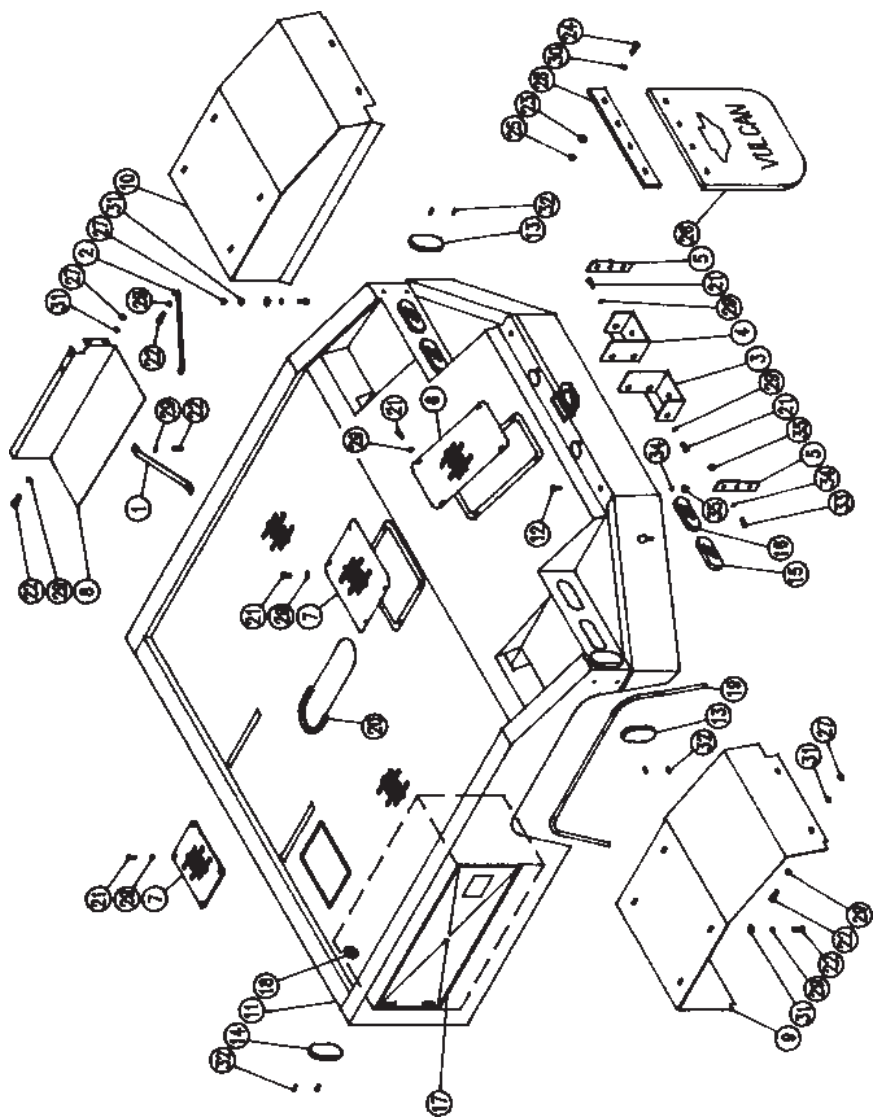

FIG 10. 890032000. BODY ASSEMBLY

ID NO	PART NO	DESCRIPTION	QTY
1	880030001	SUPPORT STRAP	1
2	880030002	SUPPORT STRAP, INNER FENDER	1
3	880030500	CHAIN POCKET, LH	1
4	880037500	CHAIN POCKET, RH	1
5	880090002	REAR CHASSIS MTG. PLATE	2
6	880090005	ACCESS COVER PLATE REAR DCV	1
7	880090006	ACCESS COVER PLATE	1
8	880090008	COVER PLATE FRONT COVER	1
9	880090500	INNER FENDER, LH	1
10	880097500	INNER FENDER, RH	1
11	890150000	BODY, 60" CA	1
12	9043948	1/2" HC X 1-1/2" CARRIAGE BOLT	2
13	9025059	MARKER LIGHT - RED	4
14	9025060	MARKER LIGHT - AMBER	2
15	9025069	STOP/TAIL LIGHT	2
16	9025070	BACK UP LIGHT	2
17	9032006	WEATHER STRIP	8.1'
18	9032053	RUBBER GROMMET	1
19	9032096	TRIM	8.5'
20	9032114	RUBBER TRIM	1.1'
21	9041001	1/4" NC X 1/2" HEX HD CAP SCREW	18
22	9041004	1/4" HC X 7/8" HEX HD CAP SCREW	20
23	9045204	5/16" FLAT WASHER	8
24	9041104	5/16" NC X 7/8" HEX HD CAP SCREW	8
25	9043102	5/16" NC HEX NUT	8
26	9032092	MUD FLAP OPTIONAL	2
27	9043125	1/4" NC HEX NUT	6
28	804500001	MUD FLAP PLATE	2
29	9045055	1/4" LOCK WASHER	40
30	9045056	5/16" LOCK WASHER	8
31	9045253	1/4" FLAT WASHER	16
32	9046527	3/16" POP RIVET	20
33	9044405	1/2" NC X 1-3/4" HEX HD GR 8 SCREW	4
34	9045257	1/2" FLAT WASHER	6
35	9043311	1/2" NYLOK HEX NUT	6

FIG 11. 890032000. BODY ASSEMBLY - ROD CONTROLS

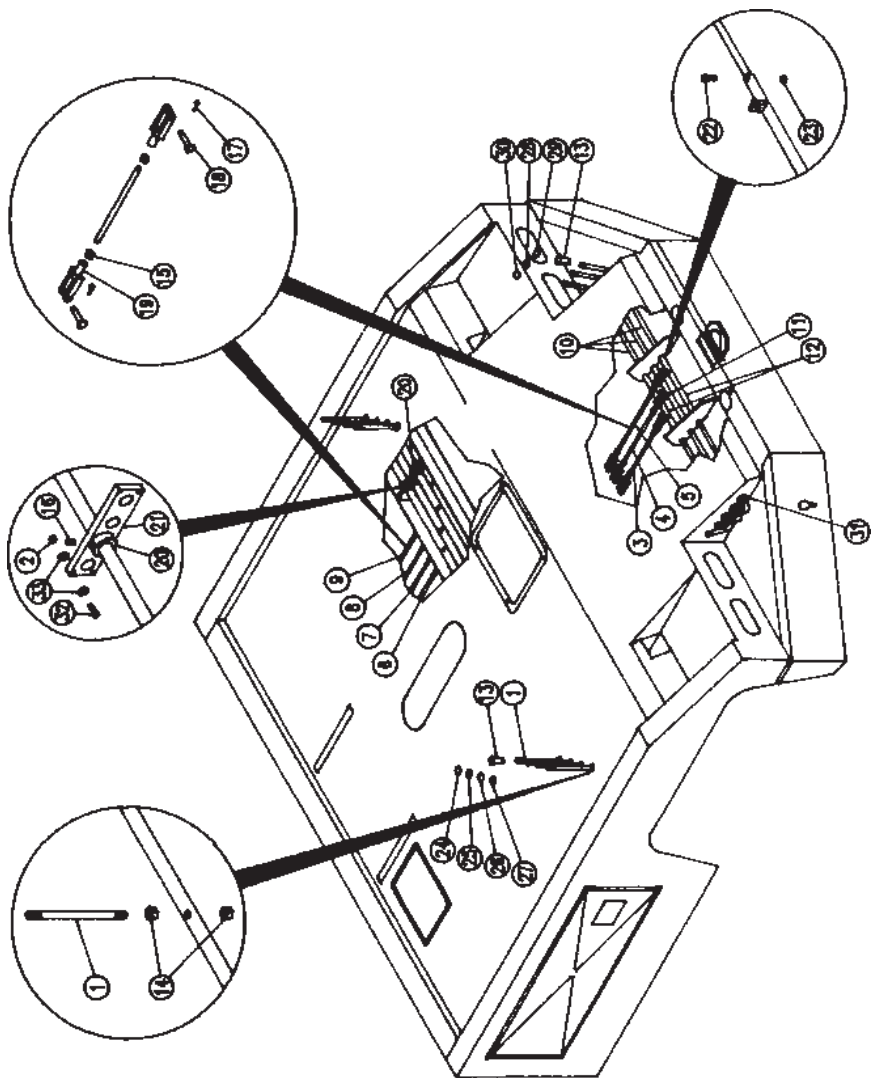

FIG 11. 890032000. BODY ASSEMBLY - ROD CONTROLS

ID NO	PART NO	DESCRIPTION	QTY
1	880460008	CONTROL HANDLE	8
2	9043334	5/16" NYLOK HEX NUT	8
3	880465001	3" CONTROL ROD	1
4	880465002	4-1/2" CONTROL ROD	1
5	880465003	6" CONTROL ROD	1
6	880465004	9 CONTROL ROD	1
7	880465005	10-1/2" CONTROL ROD	1
8	880465006	12" CONTROL ROD	1
9	880465007	13-1/2" CONTROL ROD	1
10	880470001	CONTROL ROD	6
11	880470500	REAR CONTROL ROD	1
12	880471000	REAR CONTROL ROD	2
13	9032106	CONTROL KNOB	14
14	9043129	1/2" NC HEX NUT	16
15	9043171	5/16" NF HEX NUT	14
16	9043939	5/16" NC X 3/8" SELF LOCK SET SC	8
17	9046009	3/32" COTTER PIN	14
18	9046501	5116" CLEVIS PIN	14
19	9048006	5/16" YOKE END	14
20	9048637	COLLAR	8
21	9031240	UHMW CONTROL ROD MOUNTING PAD	2
22	9043419	#8-32 X 1" SOCKET HD CAP SCREW	6
23	9043395	#8-32 NYLOK HEX NUT	6
24	9033156	DECAL-LH WINCH	2
25	9033149	DECAL-RH WINCH	2
26	9033151	DECAL-BOOM IN/OUT	2
27	9033152	DECAL-BOOM UP/DOWN	2
28	9033153	DECAL-STINGER TILT	2
29	9033155	DECAL-STINGER UP/DOWN	2
30	9033154	DECAL-STINGER IN/OUT	2
31	9053715	BUSHING	12
32	9041108	5/16" X 1 3/4" HEX HD CAP SCREW	8
33	9045353	5/16" SAE FLAT WASHER	16

FIG 12. 880020000. SUBFRAME ASSEMBLY

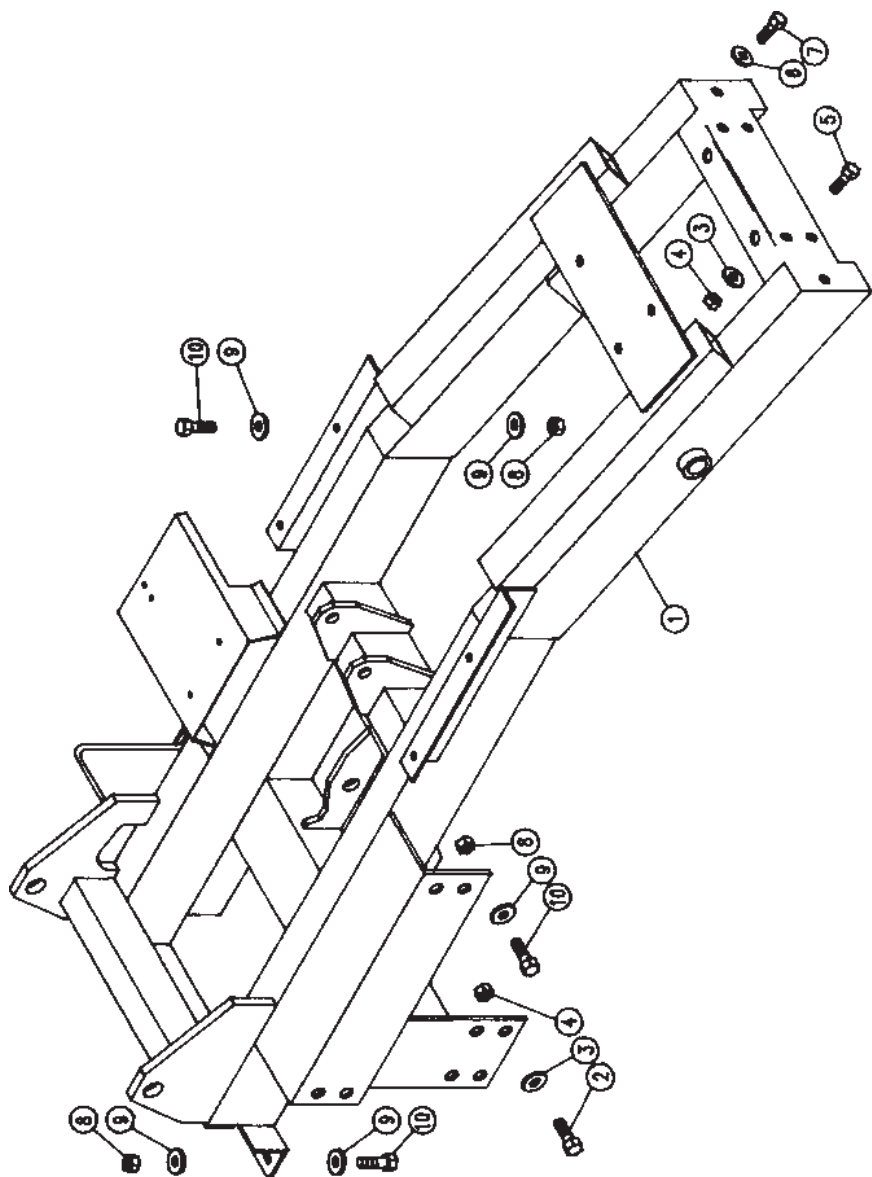

FIG 12. 880020000. SUBFRAME ASSEMBLY

ID NO	PART NO	DESCRIPTION	QTY
1	880020000	SUBFRAME ASSEMBLY	1
2	9043889	5/8" X 1 3/4" HEX HD GRADE 8 SCREW	8
3	9045358	5/8" FLAT WASHER	12
4	9043307	5/8" NC NYLOK HEX NUT	12
5	9044409	5/8" X 2 1/4" HEX HD GRADE 5 SCREW	4
6	9045061	5/8" LOCK WASHER	2
7	9041601	5/8" X 1 3/4" HEX HD CAP SC GRD 5	2
8	9043311	1/2" NYLOK HEX NUT	10
9	9045257	1/2" FLAT WASHER	16
10	9041403	1/2" X 1-1/2" HEX HD CAP SCREW	10

FIG 13. 880680000. BOOM EXTENSION CYLINDER

BOOM EXTENSION CYLINDER
PART NO. 880680000

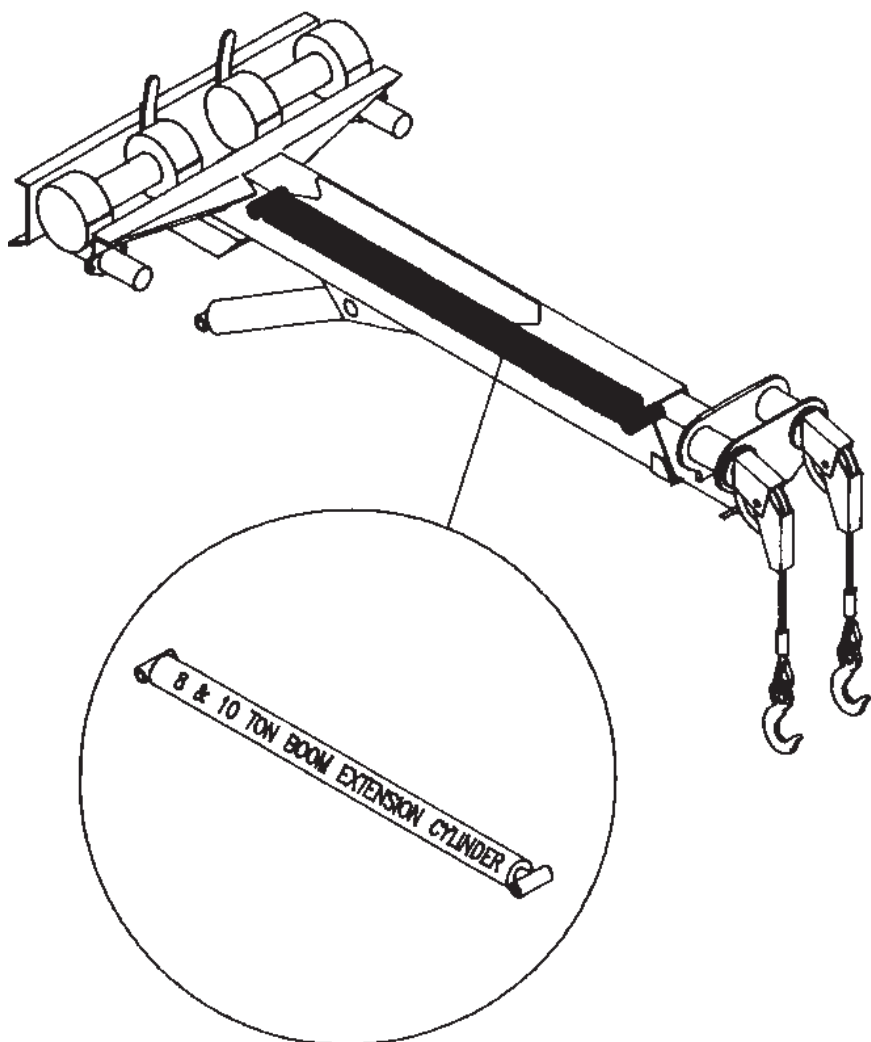

FIG 14. 880660000. 8 TON BOOM LIFT CYLINDER

8 TON BOOM LIFT CYLINDER
PART NO. 880660000

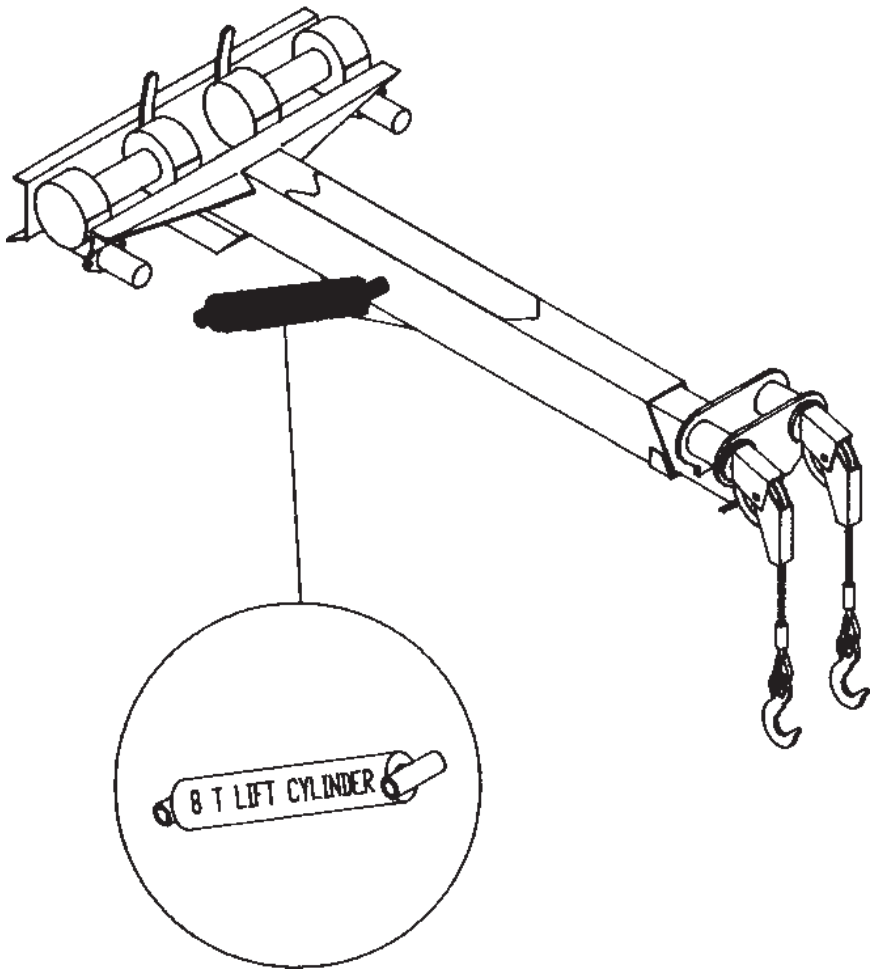

FIG 15. 880740000. 10 TON BOOM LIFT CYLINDER

10 TON BOOM LIFT CYLINDER
PART NO. 880740000

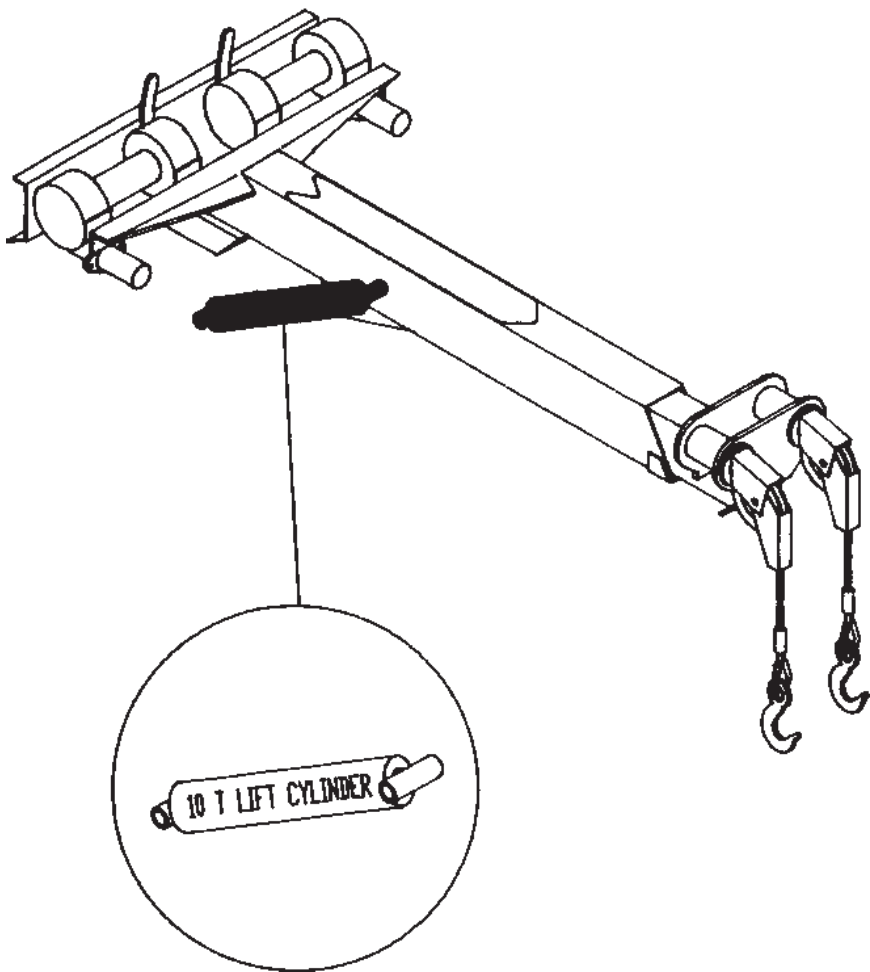
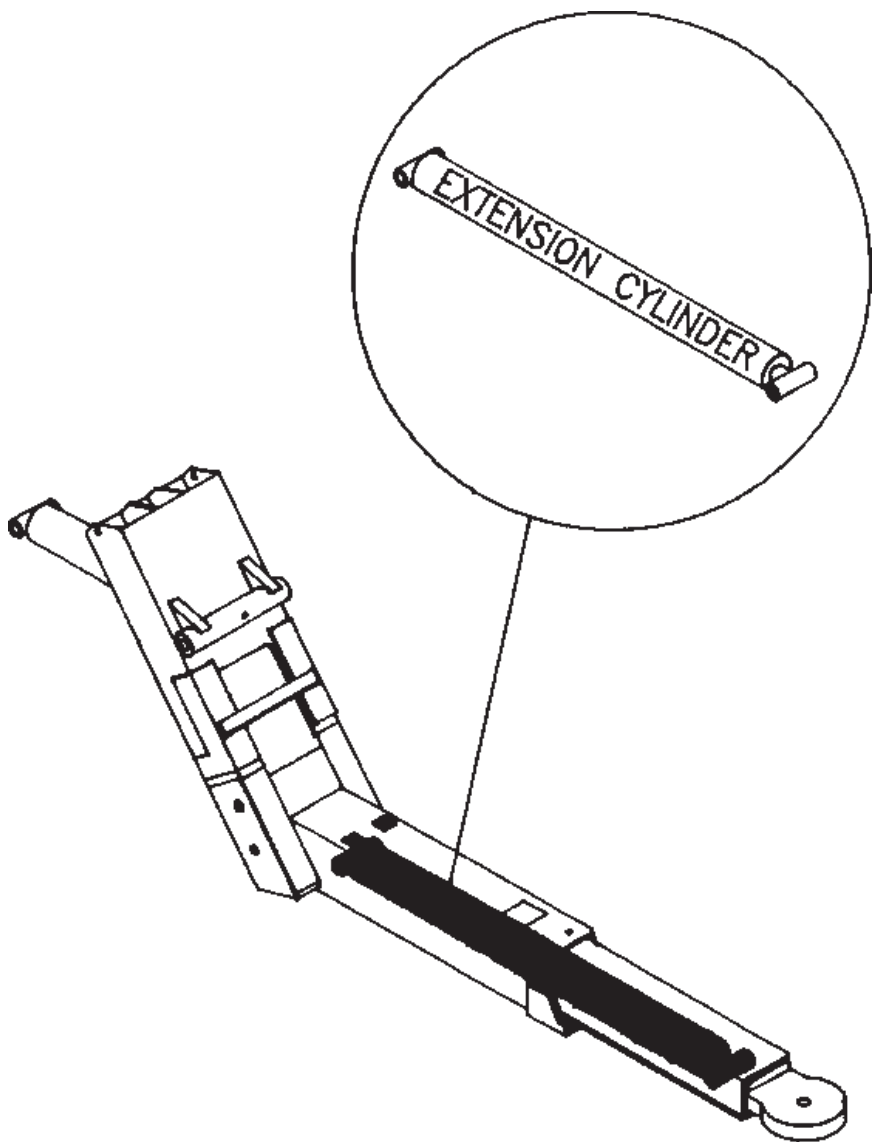
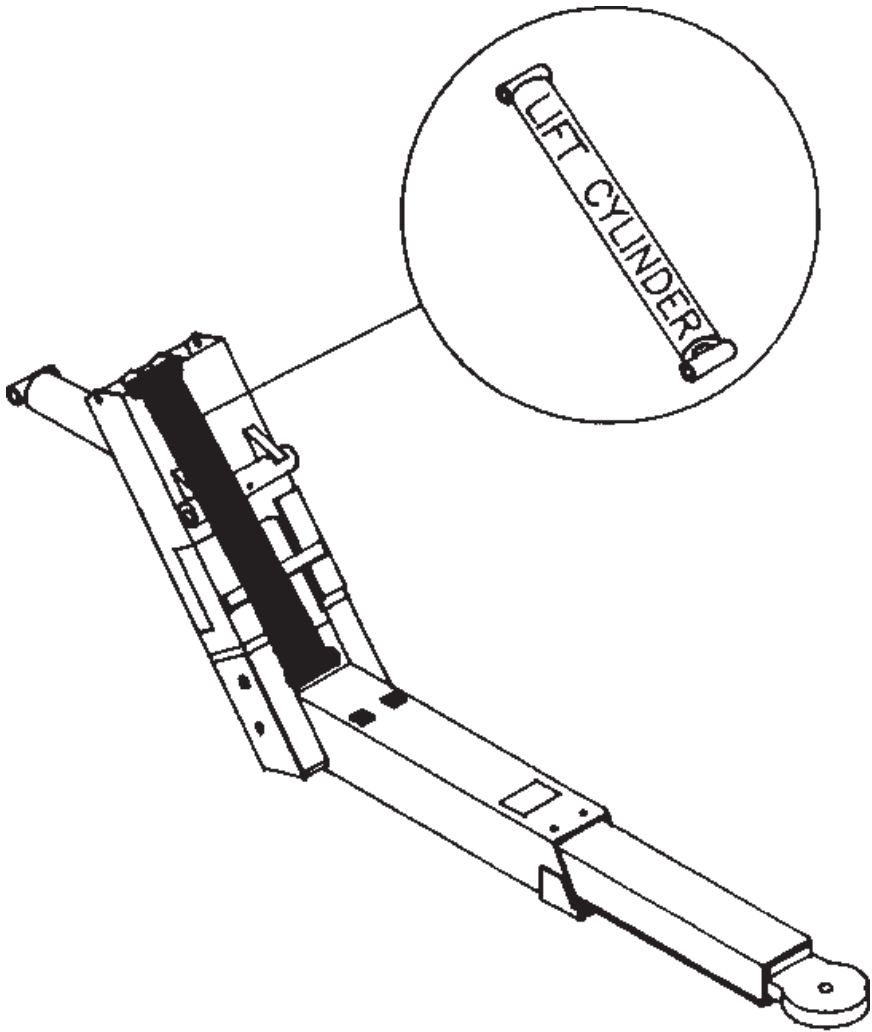

FIG 16. 880730000. 880/890 STINGER EXTENSION CYLINDER



880/890 STINGER EXTENSION CYLINDER
PART NO. 880730000

FIG 17. 880650000. STINGER LIFT CYLINDER



STINGER LIFT CYLINDER
PART NO. 880650000

FIG 18. 880670000. STINGER LIFT CYLINDER

STINGER TILT CYLINDER
PART NO. 880670000

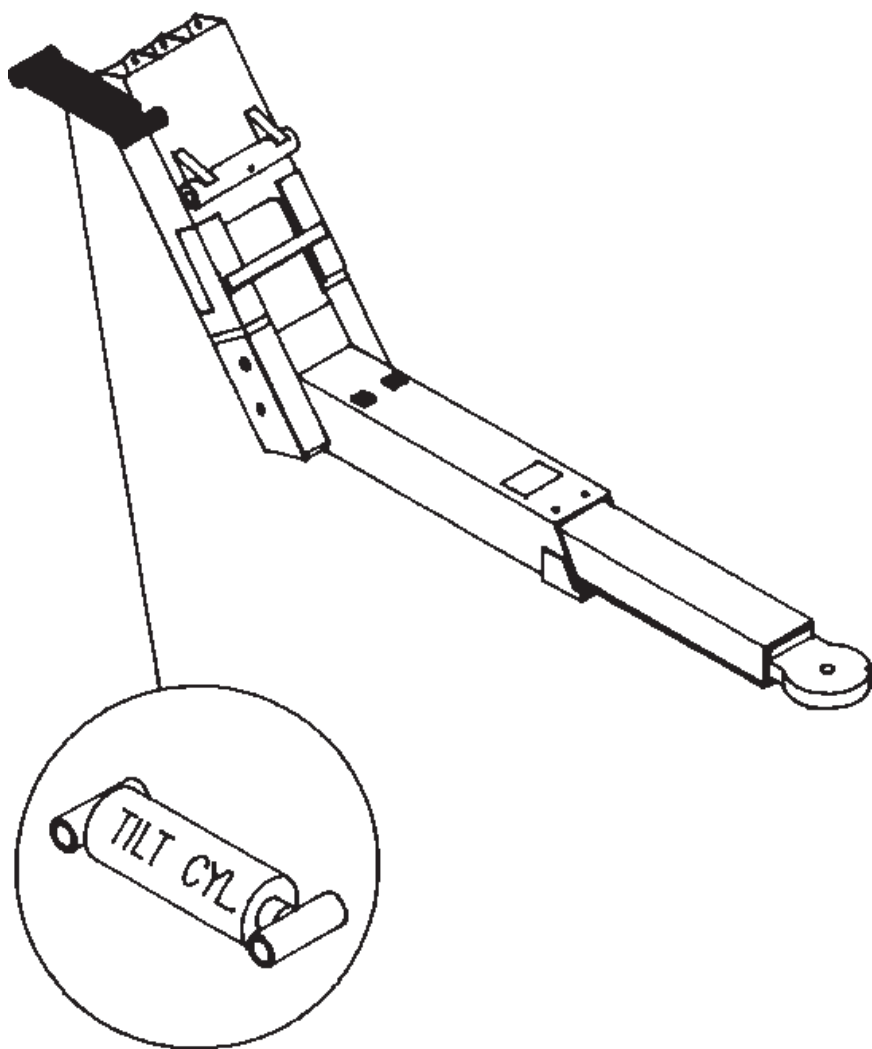

FIG 19. OPTIONAL EQUIPMENT

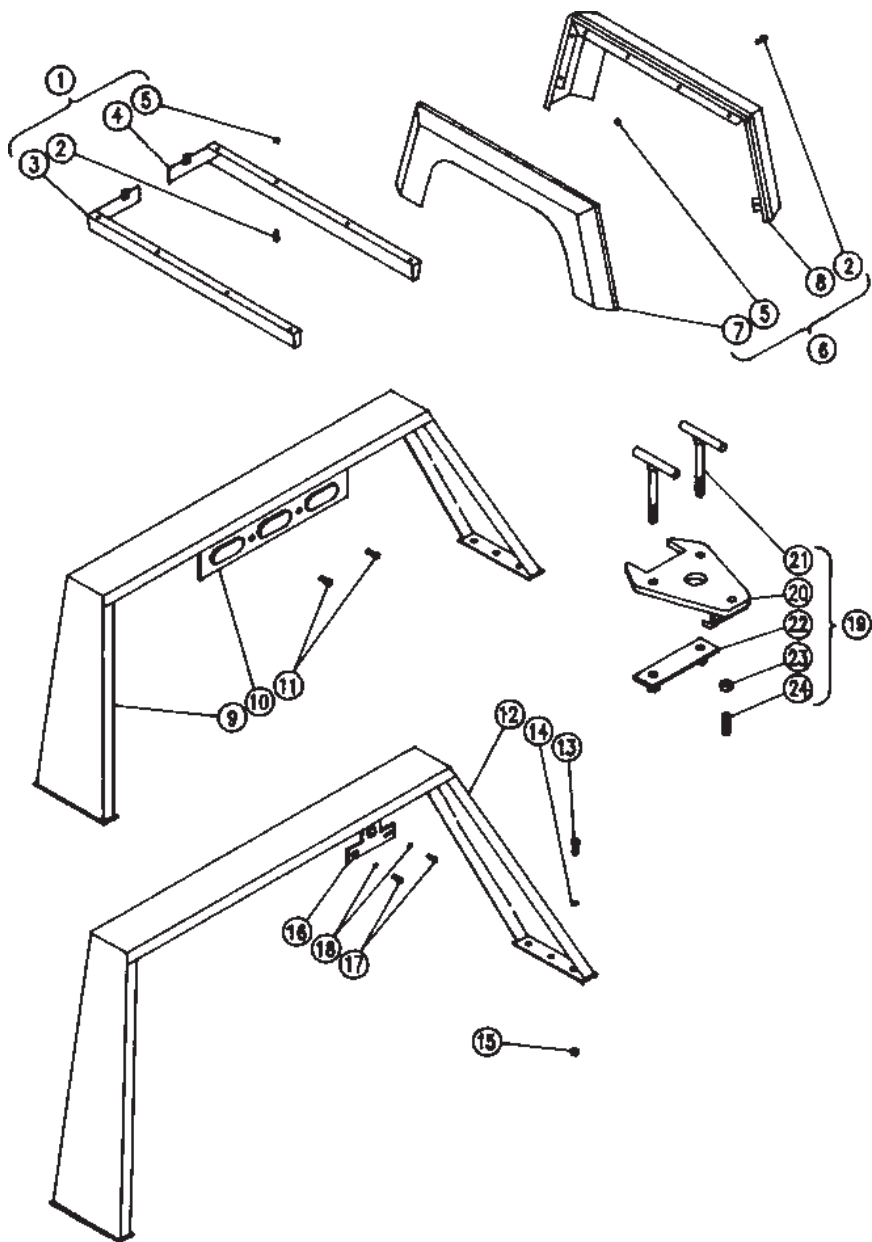

FIG 19. OPTIONAL EQUIPMENT

ID NO	PART NO	DESCRIPTION	QTY
1	880181000	FENDER SKIRT KIT (CHEV 3500)	1
2	9041005	1/4" NC X 1" HEX HD CAP SCREW	20
3	880181100	FENDER SKIRT, LH	1
4	880188100	FENDER SKIRT, RH	1
5	9043319	1/4" NYLOK HEX NUT	20
6	880180000	FENDER FLARE KIT	1
7	880180500	FENDER FLARE, LH	1
8	880187500	FENDER FLARE, RH	1
9	880560000	SHORT LIGHT PYLON (27")	1
10	9025006	THREE CLUSTER LIGHT BAR	1
11	9046527	3/16" POP RIVET	2
12	880550000	LIGHT PYLON (30")	1
13	9041402	1/2" NC X 1 1/4" HEX HD CAP SCREW	6
14	9045257	1/2" FLAT WASHER	6
15	9043311	1/2" NYLOK HEX NUT	6
16	9025062	LICENSE PLATE BRACKET	1
17	9043882	#8-32 SELF TAPPING SCREW	2
10	9045052	#8 LOCK WASHER	2
19	8608700	TRAILER HITCH KIT	1
20	8501340	TRAILER HITCH BRACKET	1
21	8501330	HANDLE SCREW	2
22	8609500	BRIDGE BAR	1
23	9043205	1/2" NC JAM NUT	1
24	9044177	1/2" NC X 1 1/4" SET SCREW	1

FIG 20. 880140000. DECK MOUNTED WINCH ASSEMBLY

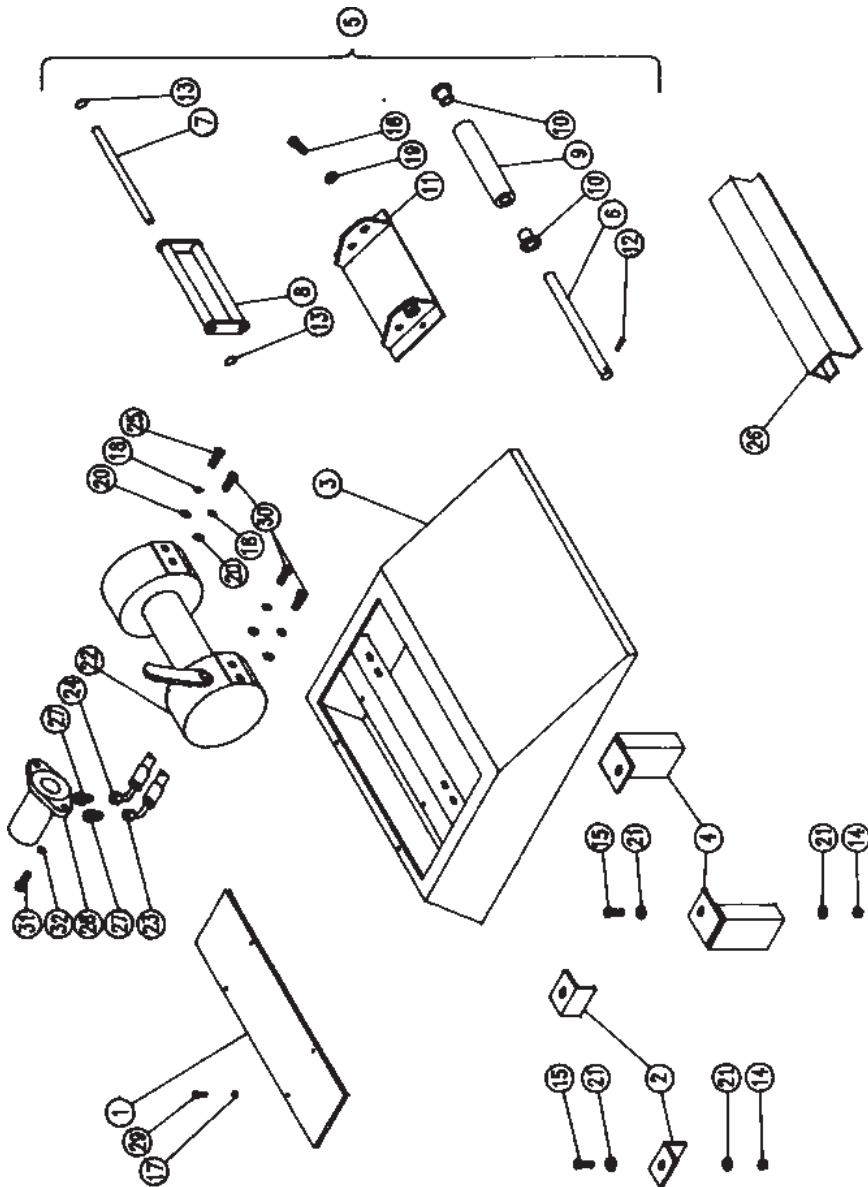
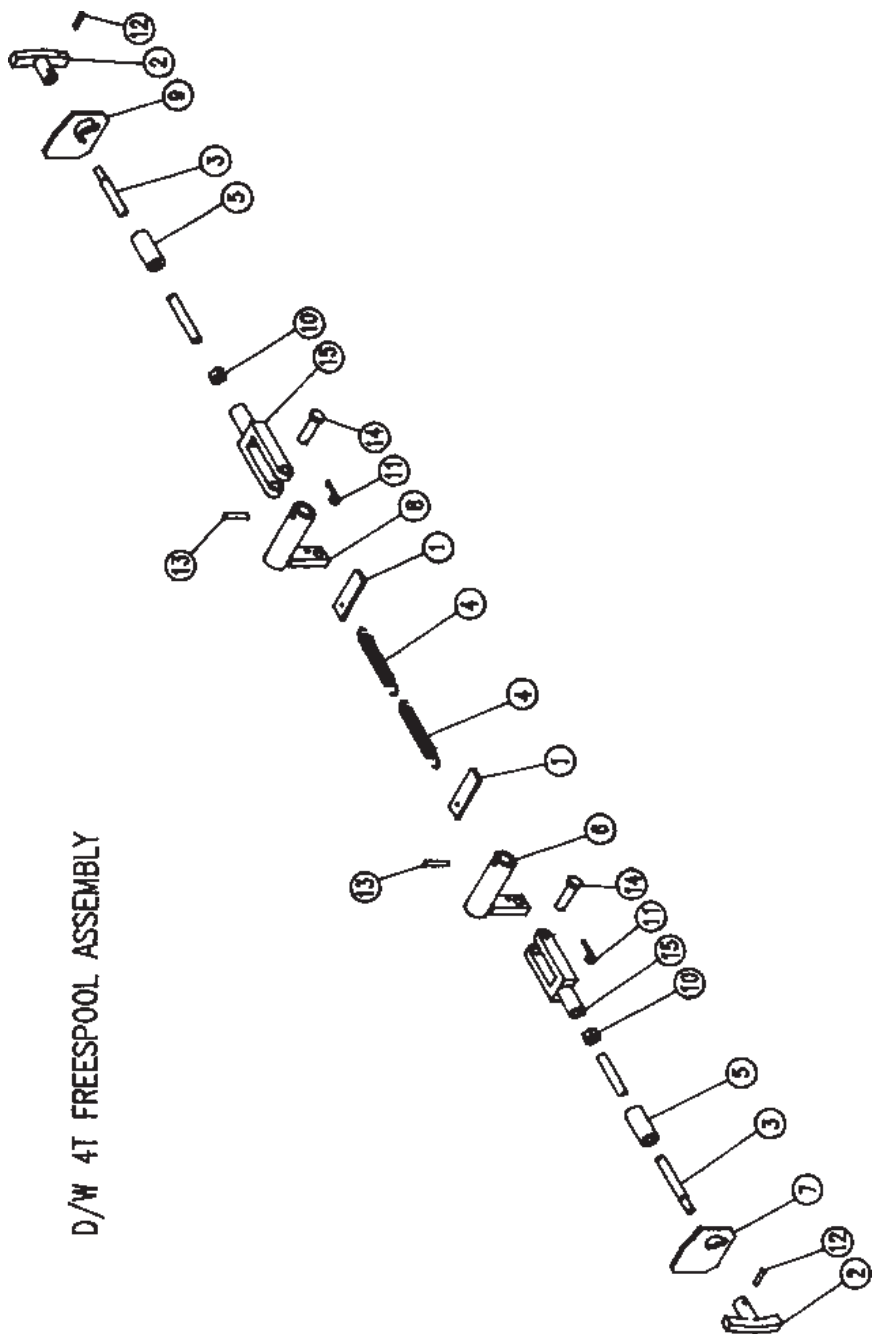

FIG 20. 880140000. DECK MOUNTED WINCH ASSEMBLY

ID NO	PART NO	DESCRIPTION	QTY
1	880140001	COVER PANEL	1
2	880140002	REAR MTD. ANGLE	2
3	880140500	DECK MOUNTED WINCH BRACKET	1
4	880141000	FRONT MTD. BRACKET	2
S	880141600	ROLLER ASSEMBLY	1
6	8606301	ROLLER SHAFT	1
7	8606302	WIRE GUIDE PIVOT PIN	1
8	8606500	WIRE GUIDE	1
9	8606601	ROLLER	1
10	9053722	FLANGE BEARING	2
11	880141500	ROLLER BRACKET	1
12	9046310	ROLL PIN	1
13	905650	1/2" NOMINAL HD RETAINER RING	2
14	9043307	5/8" NC NYLOK HEX NUT	4
15	9043869	5/8" NC X 2" HEX HD CAP SCREW	4
16	9043894	1/2" NC X 1 1/2" HEX HD CAP SCREW	2
17	9045055	1/4" BS LOCK WASHER	4
18	9045057	3/8" BS LOCK WASHER	8
19	9045050	1/2" BS LOCK WASHER	4
20	9045255	3/8" BS FLAT WASHER	8
21	9045259	5/8" BS FLAT WASHER	8
22	9043136	WINCH	1
23	880010021	HYDRAULIC HOSE ASSEMBLY	1
24	880010022	HYDRAULIC HOSE ASSEMBLY	1
25	9041203	3/8" NC X 3/4" HEX HD CAP SCREW	2
26	880142000	SUPPORT CHANNEL	1
27	9012173	MALE ADAPTER - 10 SAE X 6 JIC	2
28	9016706	HYDRAULIC MOTOR	1
29	9041003	1/4" NC X 3/4" HEX HD CAP SCREW	4
30	9041206	3/8" X 1 1/4" HEX HD CAP SCREW	6
31	9041402	1/2" NC X 1 1/4" HEX HD CAP SCREW	2
32	9045059	1/2 LOCK WASHER	4

FIG 21. 880620000. FREE SPOOL ASS'Y (D/W 4T)



D/W 4T FREESPOOL ASSEMBLY

FIG 21. 880620000. FREE SPOOL ASS'Y (D/W 4T)

ID NO	PART NO	DESCRIPTION	QTY
1	880610001	SPRING PLATE	2
2	880610002	WINCH FREE SPOOL HANDLE	2
3	880610003	CONTROL ROD	2
4	880610004	SPRING	2
5	880610005	LOCK COLLAR	2
6	880621000	LH LEVER ARM	1
7	880621500	LH LOCK PLATE	1
8	880628000	RH LEVER ARM	1
9	880628500	RH LOCK PLATE	1
10	9043155	1/2" HF HEX NUT	2
11	9046118	COTTER PIN 1/8" DIA. X 1" LG.	2
12	9046305	3/16" X 3/4" LG ROLL PIN	2
13	9046311	3/16" X 1 1/4" LG ROLL PIN	2
14	9046545	CLEVIS PIN	2
15	9048450	CLEVIS YOKE	2

FIG 22. 880610000. FREE SPOOL ASS'Y (D/W 5T)

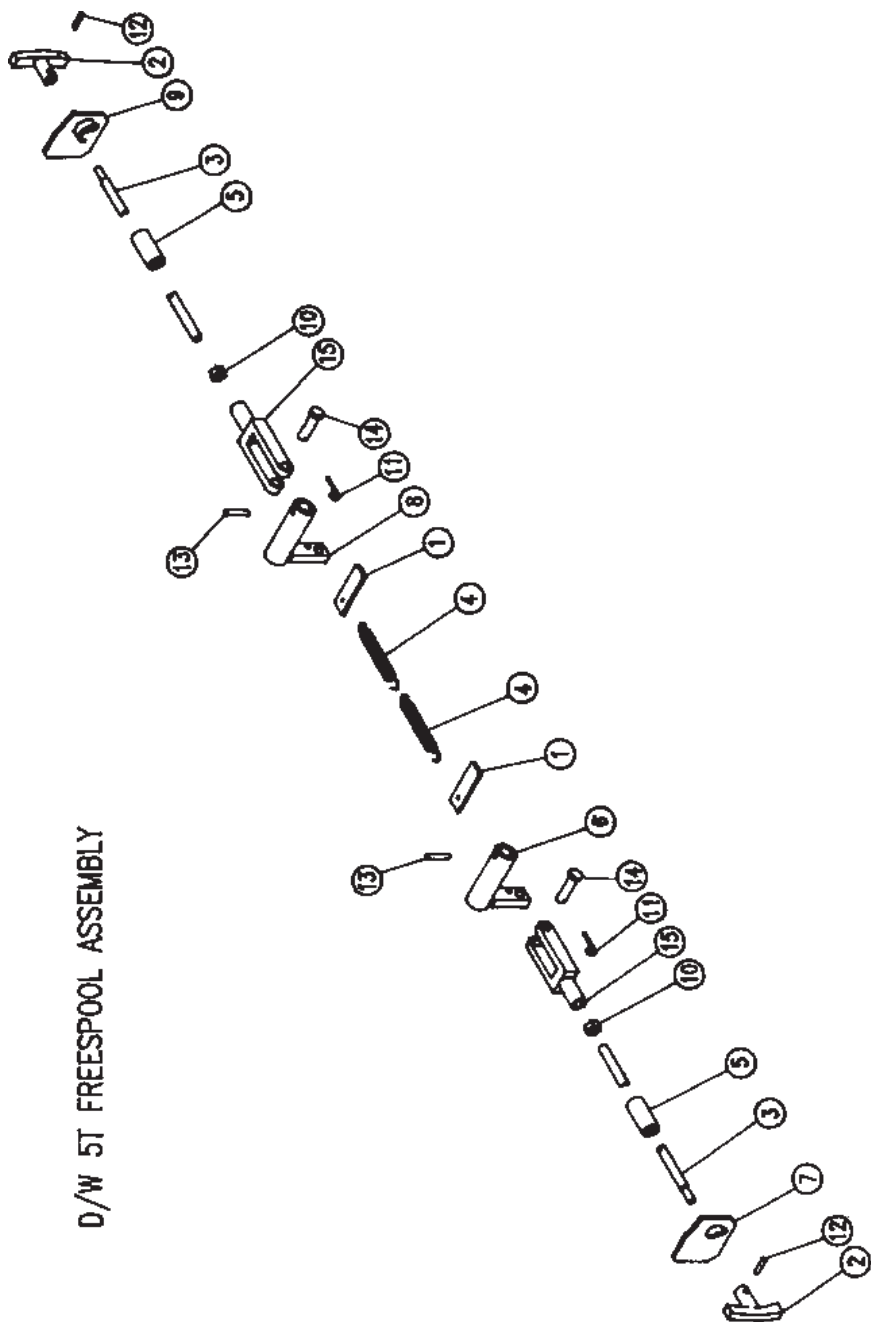
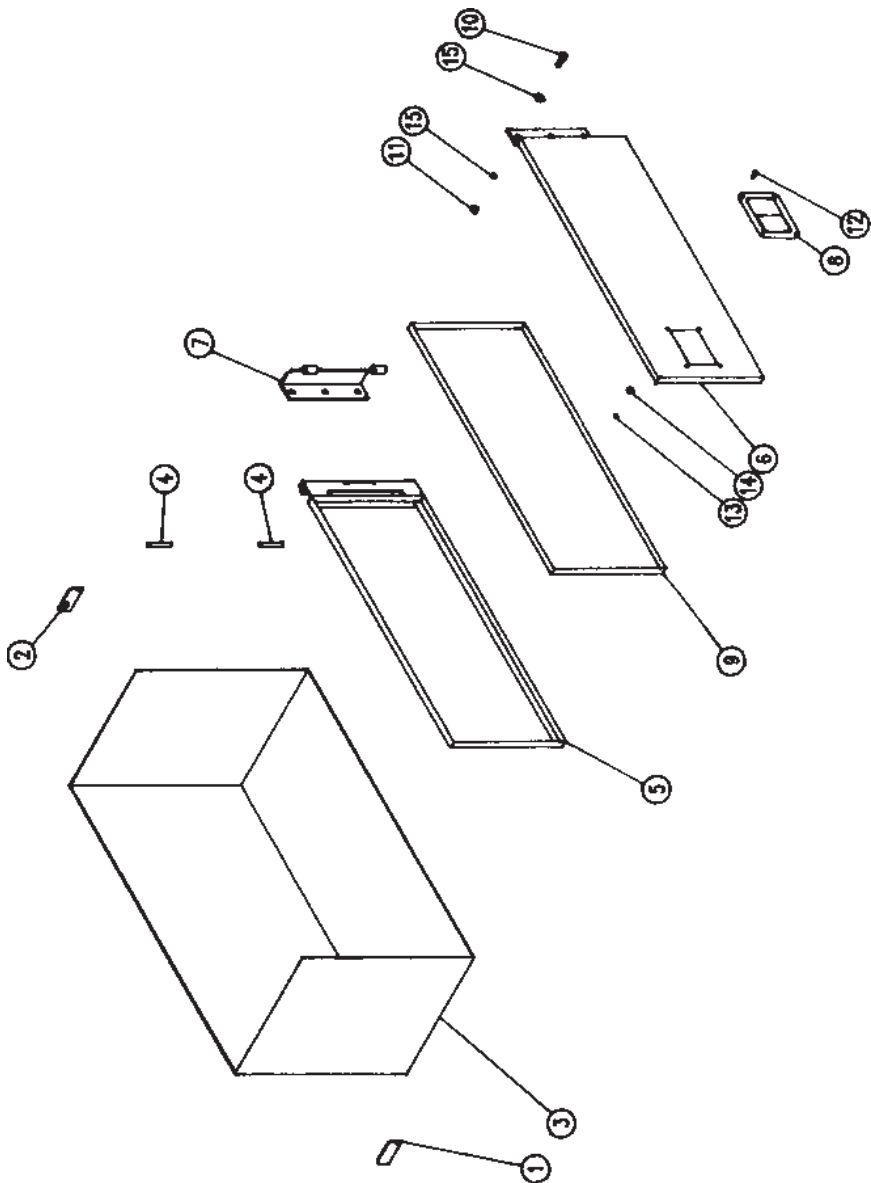

FIG 22. 880610000. FREE SPOOL ASS'Y (D/W 5T)

ID NO	PART NO	DESCRIPTION	QTY
1	880610001	SPRING PLATE	2
2	880610002	WINCH FREE SPOOL HANDLE	2
3	880610003	CONTROL ROD	2
4	880610004	SPRING	2
5	880610005	LOCK COLLAR	2
6	880611000	LH LEVER ARM	1
7	880611500	LH LOCK PLATE	1
8	880618000	RH LEVER ARM	1
9	880618500	RH LOCK PLATE	1
10	9043155	1/2" NF HEX NUT	2
11	9046118	COTTER PIN 1/8- DIA. X 1 LG	2
12	9046305	3/16" X 3/4" LG ROLL PIN	2
13	9046311	3/16" X 1-1/4" LG ROLL PIN	2
14	9046545	CLEVIS PIN	2
15	9048450	CLEVIS YOKE	2

FIG 23. 880640000. RH TOOL BOX INSTALLATION KIT



**FIG 23. 880640000. RH TOOL BOX INSTALLATION
KIT**

ID NO	PART NO	DESCRIPTION	QTY
1	880150002	SIDE FILLER PLATE	1
2	880150003	FRONT FILLER PLATE	1
3	880179100	TOOL BOX ENCLOSURE	1
4	880640101	HINGE PIN	1
5	880640500	DOOR FRAME W/HINGE	1
6	880641000	DOOR	1
7	880641500	DOOR HINGE	1
8	9048147	PADDLE HANDLE	1
9	9032006	WEATHER STRIP	7'
10	9041105	5/16" NC X 1- HEX HD CAP SCREW	3
11	9043334	5/16" NC NYLOK HEX NUT	3
12	9043951	#8-32 X 1" ONE WAY SCREW	4
13	9043399	#8-32 NYLOK HEX NUT	4
14	9045251	1/8" FLAT WASHER	4
15	9045204	5/16" 8S FLAT WASHER	3

FIG 24. 880810000. 24" CROSS OVER TOOL BOX

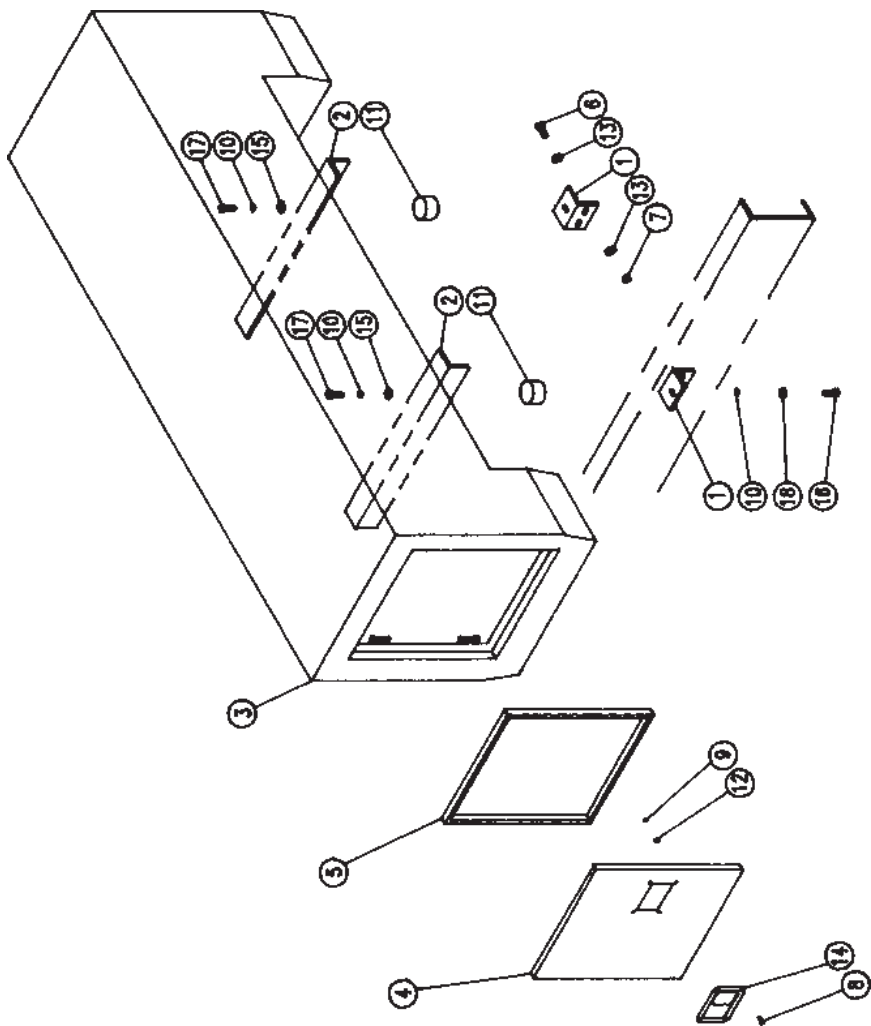

FIG 24. 880810000. 24" CROSS OVER TOOL BOX

ID NO	PART NO	DESCRIPTION	QTY
1	1616120002	TOOL BOX MOUNTING ANGLE	4
2	8615306	SUPPORT ANGLE	2
3	880810500	24" SPACER TOOL BOX	1
4	880810600	DOOR	2
5	9032139	WEATHER STRIP	6
6	9041605	5/8" NC X 2" HEX HD CAP SCREW	3
7	9043131	5/8" NC NYLOK HEX NUT	8
8	9043951	#8-32 X 1" ONE WAY SCREW	8
9	9043399	#8-32 NYLOK HEX NUT	8
10	9045059	1/2" BS LOCK WASHER	8
11	9402970	TOOL BOX MOUNTING PAD	4
12	9045251	1/8" BS FLAT WASHER	13
13	9045259	5/8" BS FLAT WASHER	16
14	9048147	PADDLE HANDLE	2
15	94310004	TOOL BOX MOUNTING WASHER	4
16	9041401	1/2" NC X 1" HEX HD CAP SCREW	4
17	9041402	1/2" NC X 1/4" HEX HD CAP SCREW	4
18	9045257	1/2" FLAT WASHER	4

FIG 25. WRECKER HYDRAULIC COMPONENTS (SW)

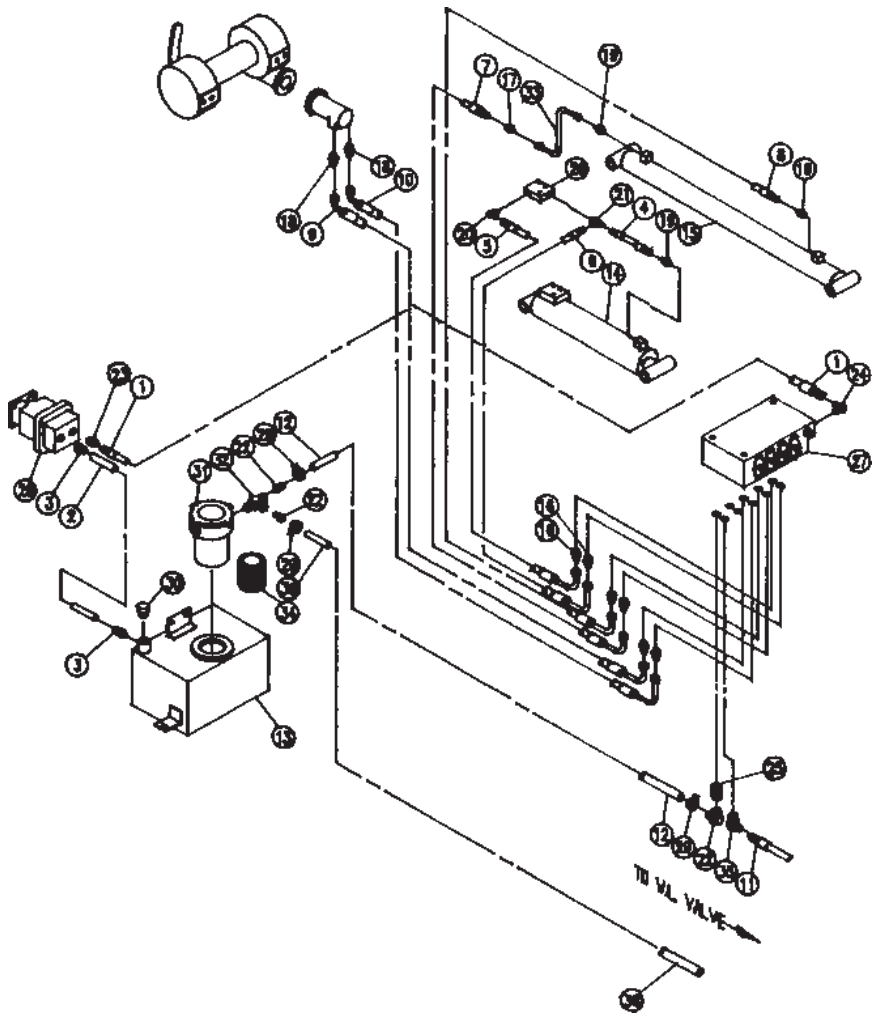

FIG 25. WRECKER HYDRAULIC COMPONENTS (SW)

ID NO	PART NO	DESCRIPTION	QTY
1	804290015	1/2" HOSE ASSEMBLY 90" LONG	
2	804290016	1-1/4" ID HOSE 90" LG.	1
3	8606811	HOSE BARB 1" NPT X 1-1/4"	2
4	880010001	HYDRAULIC HOSE ASSEMBLY 11-1/2"	1
5	880010002	HYDRAULIC HOSE ASSEMBLY 41"	1
6	880010003	HYDRAULIC HOSE ASSEMBLY 41"	1
7	880010004	HYDRAULIC HOSE ASSEMBLY 61"	1
8	880010005	HYDRAULIC HOSE ASSEMBLY 135"	1
9	880010009	HYDRAULIC HOSE ASSEMBLY 72"	1
10	880010010	HYDRAULIC HOSE ASSEMBLY 72"	1
11	880010027	HYDRAULIC TBG. (POWER BEYOND)	1
12	880010018	HYDRAULIC HOSE ASSEMBLY 26"	1
13	805031500	HYDRAULIC TANK WELDMENT	1
14	880660000	8T BOOM LIFT CYLINDER	1
	880740000	10T BOOM LIFT CYLINDER	1
15	880680000	BOOM EXTENSION CYLINDER	1
16	9011653	9/16"-18 JIC X 3/4"-16 SAE	6
17	9011675	3/8" X 3/8" NPSN MALE CONNECTOR	1
18	9012173	MALE ADAPTER - 10 SAE X 6 JIC	2
19	9012565	MALE CON 9/16"-18 JIC X 9/16"-18 SA	3
20	9012593	90° ELBOW 9/16"-18 JIC X 9/16"	1
21	9012594	RUN TEE 06J-X-06S	1
22	9012817	3/4"-3/4" BRASS HOSE BARB	4
23	9012867	STRAIGHT MALE ADAPTER 3/4" JIC	1
24	9012946	3/4" JIC X 7/8" SAE-90° ELBOW	1
25	9012981	#12 SAE X 3/4" NPT 90° FEM SWIVEL	1
26	9015739	HOLDING VALVE	1
27	9015752	3 SPOOL VALVE	1
28	9016664	HYDRAULIC PUMP	1
29	9018016	#20 HOSE CLAMP	4
30	9018131	BREATHER CAP	1
31	9018307	FILTER	1
32	9012945	3/4" NPT STREET TEE	1
33	880010024	3/8" TUBE ASSEMBLY	1
34	9018309	FILTER ELEMENT	1
35	9012932	#8 JIC X #8 SAE ELBOW	1
36	880010019	3/4" RETURN HOSE - 83" LONG	1

FIG 26. WRECKER HYDRAULIC COMPONENTS (DW)

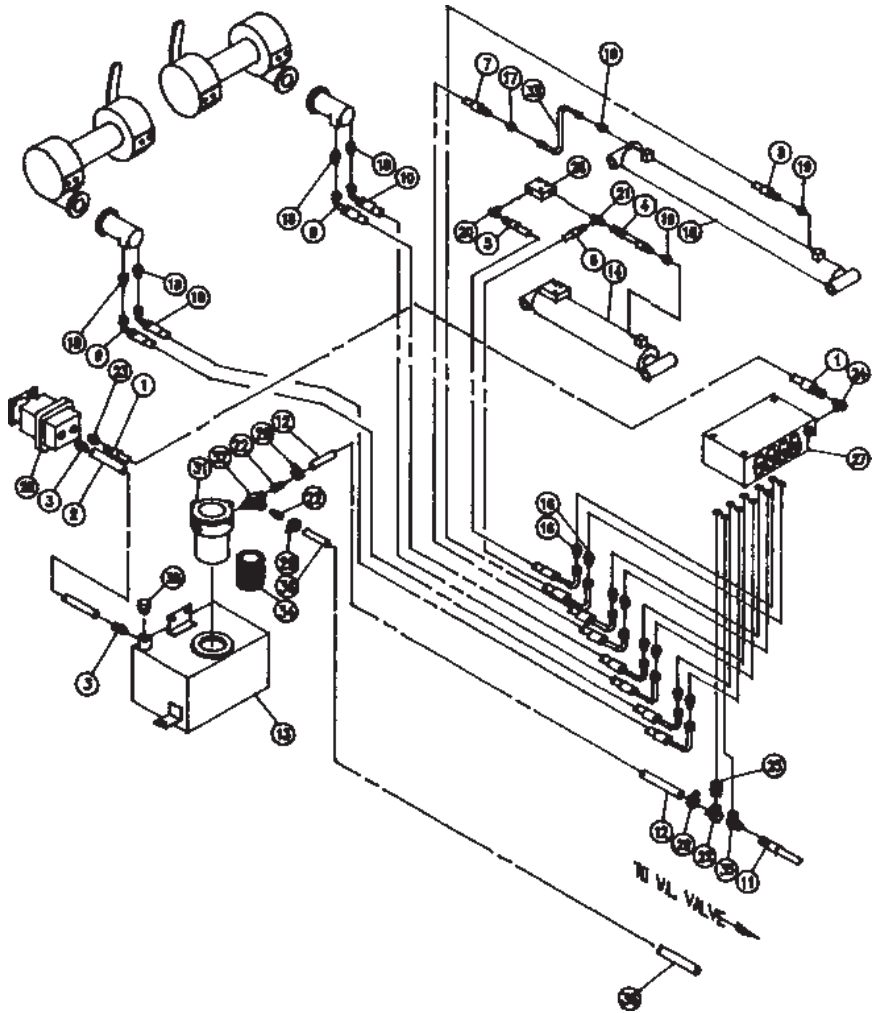

FIG 26. WRECKER HYDRAULIC COMPONENTS (DW)

ID NO	PART NO	DESCRIPTION	QTY
1	804290015	1/2" HOSE ASSEMBLY 90" LONG	1
2	804290016	1-1/4" ID HOSE 90" LONG	1
3	8606811	HOSE BARB 1" NPT X 1-1/4"	2
4	880010001	HYDRAULIC HOSE ASSEMBLY 11-1/2"	1
5	880010002	HYDRAULIC HOSE ASSEMBLY 41"	1
6	880010003	HYDRAULIC HOSE ASSEMBLY 41"	1
7	880010004	HYDRAULIC HOSE ASSEMBLY 61"	1
8	880010005	HYDRAULIC HOSE ASSEMBLY 135"	1
9	880010009	HYDRAULIC HOSE ASSEMBLY 72"	2
10	880010010	HYDRAULIC HOSE ASSEMBLY 72"	2
11	880010027	HYDRAULIC TBG. (POWER BEYOND)	1
12	880010018	HYDRAULIC HOSE ASSEMBLY 26"	1
13	805031500	HYDRAULIC TANK WELDMENT	1
14	880660000	8T BOOM LIFT CYLINDER	1
	880740000	10T BOOM LIFT CYLINDER	1
15	880680000	BOOM EXTENSION CYLINDER	1
16	9011653	9/16"-18 JIC X 3/4"-16 SAE	8
17	9011675	3/8" X 3/8" NPSN MALE CONNECTOR	1
18	9012173	MALE ADAPTER - 10 SAE X 6 JIC	4
19	9012565	MALE CON 9/16"-18JIC X 9/16"-18SAE	3
20	9012593	90° ELBOW 9/16"-18JIC X 9/16"	1
21	9056125	RUN TEE 06J-X-06S	1
22	9012817	3/4" - 3/4" BRASS HOSE BARB	4
23	9012867	STRAIGHT VALE ADAPTER 3/4" JIC	1
24	9012946	3/4" JIC X 7/8" SAE-90° ELBOW	1
25	9012981	#12SAE X 3/4"NPT 90° FEMALE SWIVEL	1
26	9015739	HOLDING VALVE	1
27	9015754	4 SPOOL VALVE	1
28	9016661	HYDRAULIC PUMP	1
29	9018016	#20 HOSE CLAMP	4
30	9018131	BREATHER CAP	1
31	9018307	FILTER	1
32	9012945	3/4" NPT STREET TEE	1
33	880010024	3/8" TUBE ASSEMBLY	1
34	9018309	FILTER ELEMENT	1
35	9012932	#8 JIC X #8 SAE ELBOW	1
36	880010019	3/4" RETURN HOSE - 83"	1

FIG 27. UNDERLIFT HYDRAULIC COMPONENTS

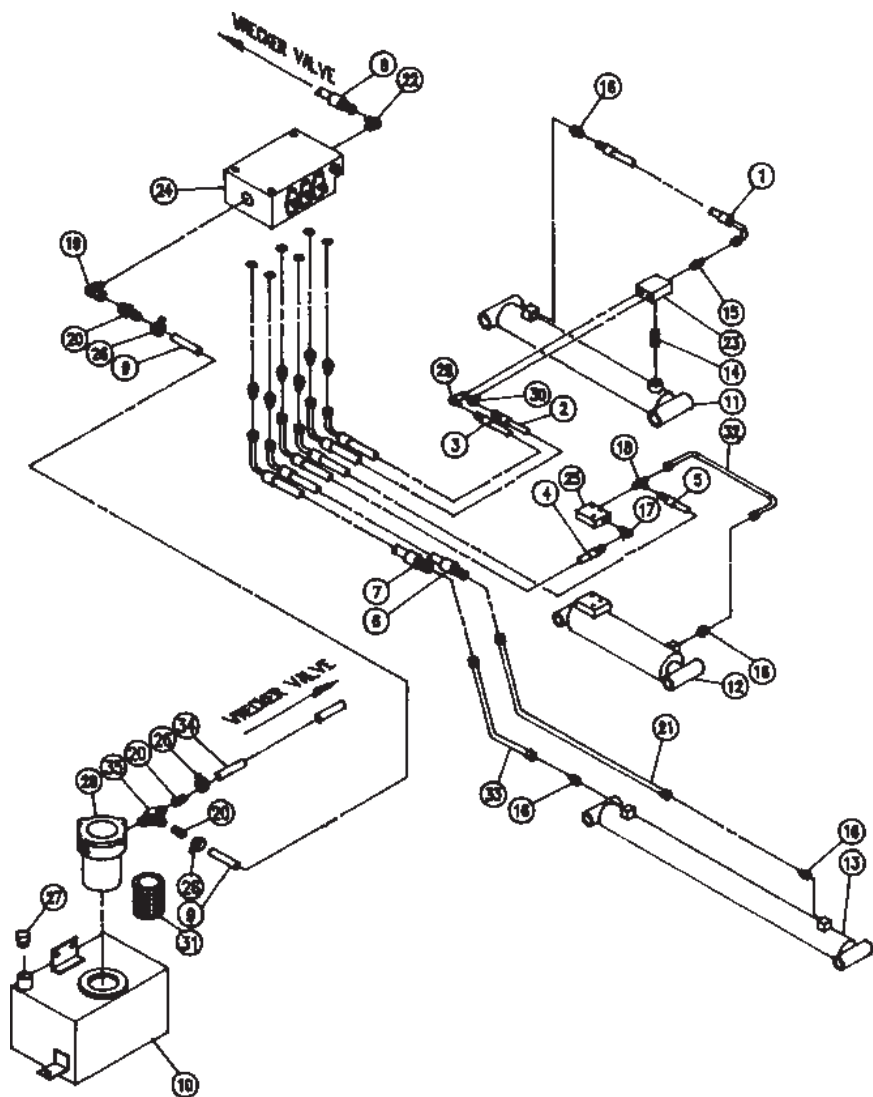
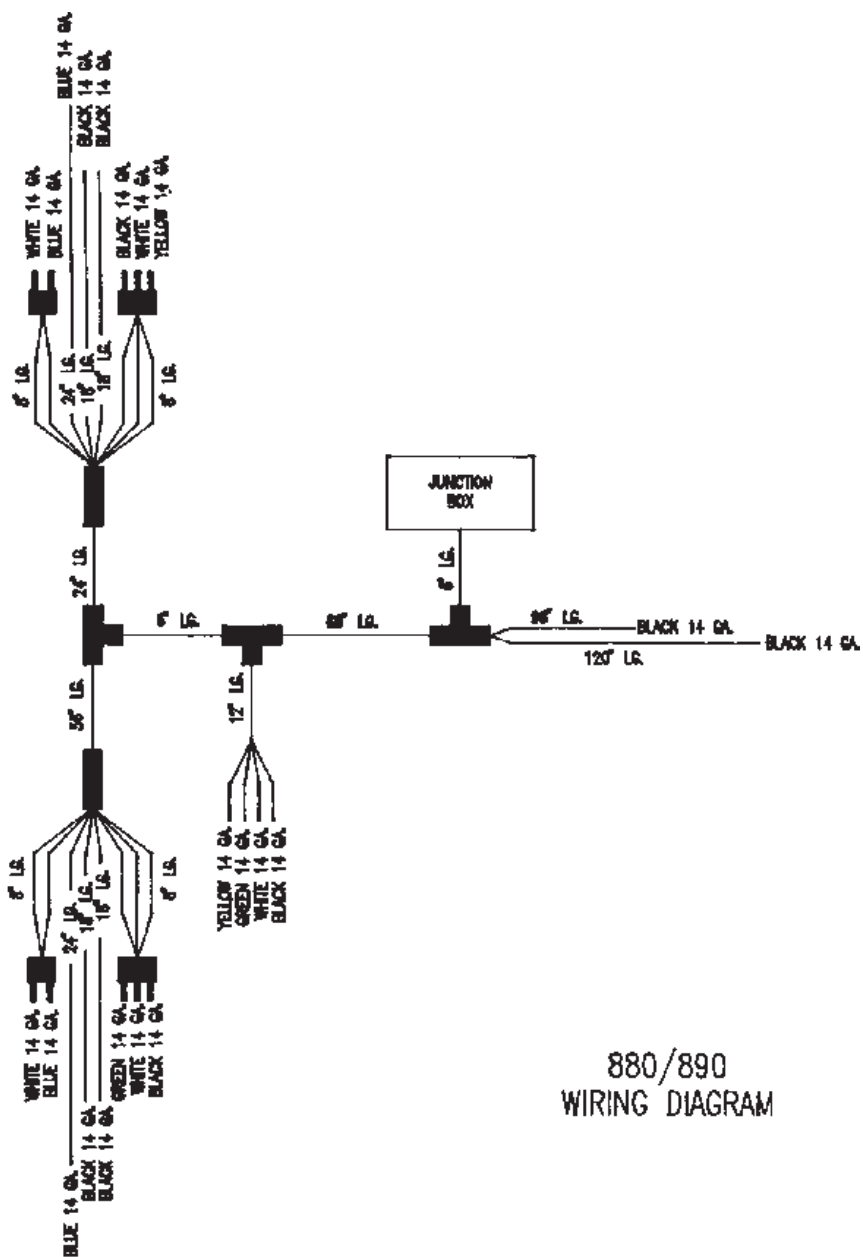

FIG 27. UNDERLIFT HYDRAULIC COMPONENTS

ID NO	PART NO	DESCRIPTION	QTY
1	880010006	HYDRAULIC HOSE ASSEMBLY 40"	1
2	880010007	HYDRAULIC HOSE ASSEMBLY 25-1/2"	1
3	880010008	HYDRAULIC HOSE ASSEMBLY 25-1/2"	1
4	880010012	HYDRAULIC HOSE ASSEMBLY 83"	1
5	880010013	HYDRAULIC HOSE ASSEMBLY 68"	1
6	880010015	HYDRAULIC HOSE ASSEMBLY 57"	1
7	880010016	HYDRAULIC HOSE ASSEMBLY 57"	1
8	880010027	HYDRAULIC TBG. (POWER BEYOND)	1
9	880010019	3/4" RETURN HOSE 83"	1
10	805031500	HYDRAULIC TANK WELDMENT	1
11	880650000	STINGER LIFT CYLINDER	1
12	880670000	STINGER TILT CYLINDER	1
13	880730000	STINGER EXTEND CYLINDER	1
14	9011610	3/8" HEX NIPPLE	1
15	9011673	3/8"NPT X 9/16"JIC MALE CONNECTOR	1
16	9012565	MALE CON 9/16"-18JIC X 9/16"-18SAE	4
17	9012593	90° ELBOW 9/16"-18 JIC X 9/16"	1
18	9012594	RUN TEE 06J-X-06S	1
19	9012981	#12 SAE X 3/4" 90° FEMALE SWIVEL	1
20	9012817	3/4"-3/4" BRASS HOSE BARB	3
21	880010026	3/8" TUBE ASSEMBLY	1
22	9012946	3/8" JIC X 7/8" SAE-90° ELBOW	1
23	9015713	COUNTER BALANCE VALVE	1
24	9015733	3 SPOOL VALVE	1
25	9015739	HOLDING VALVE	1
26	9018016	#20 HOSE CLAMP	3
27	9018131	BREATHER CAP	1
28	9018307	FILTER	1
29	9011534	3/8" NPT X 9/16" JIC MALE 90°	1
30	9011501	3/8" NPT X 9/16" JIC MALE 90°	1
31	9018309	FILTER ELEMENT	1
32	880010020	3/8" TUBE ASSEMBLY	1
33	880010025	3/8" TUBE ASSEMBLY	1
34	880010018	HYDRAULIC HOSE ASSEMBLY 26"	1
25	9012945	3/4" NPT STREET TEE	1

APPENDIX A



880/890
WIRING DIAGRAM

APPENDIX A

WHEEL LIFT RATING

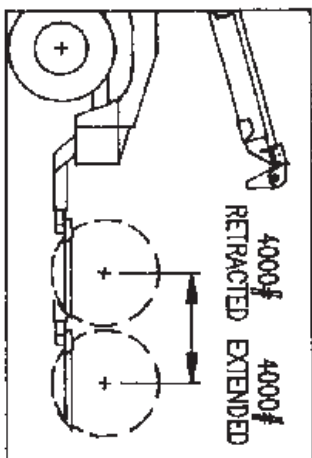

4000# RETRACTED AND EXTENDED

4000#



WHEEL LIFT EXTENSION (INCHES)
880 WHEEL LIFT

WHEEL LIFT RATINGS

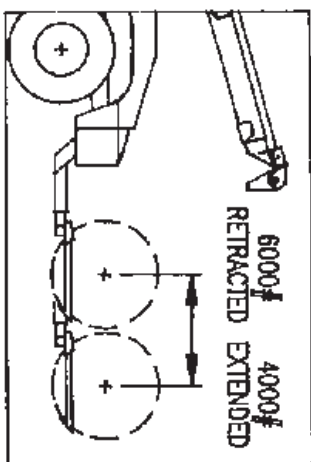

6000#
5500#
5000#
4500#
4000#

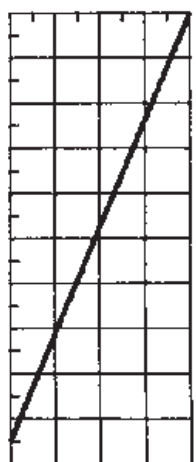

WHEEL LIFT EXTENSION (INCHES)
890 WHEEL LIFT

* AXLE FORKS - 6000# ALL EXTENSIONS - 890 ONLY.

APPENDIX A

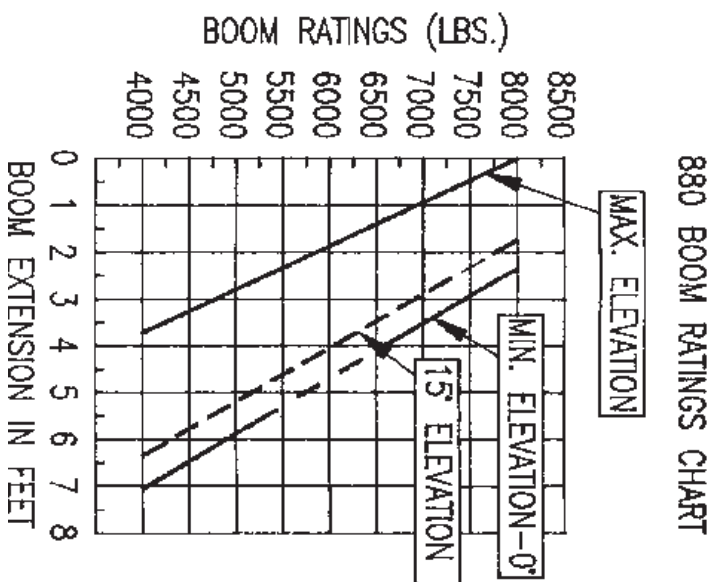
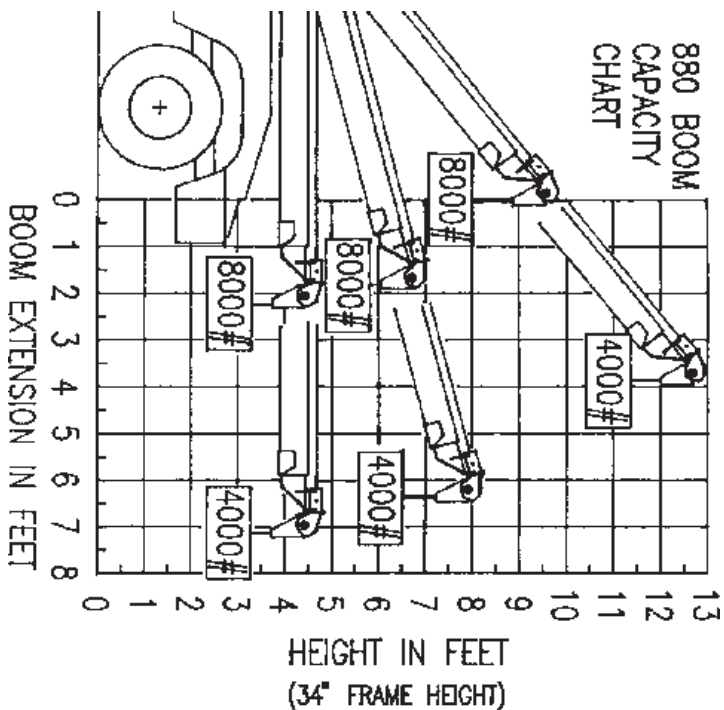

APPENDIX A

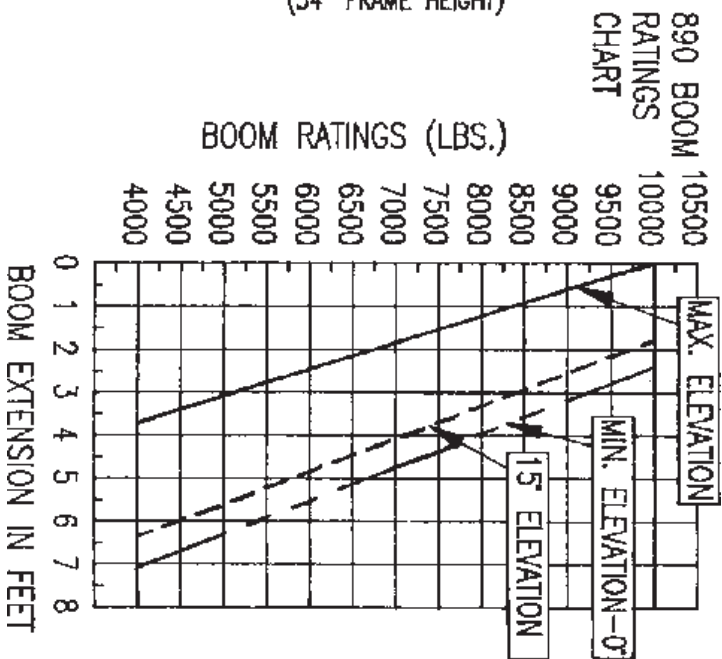
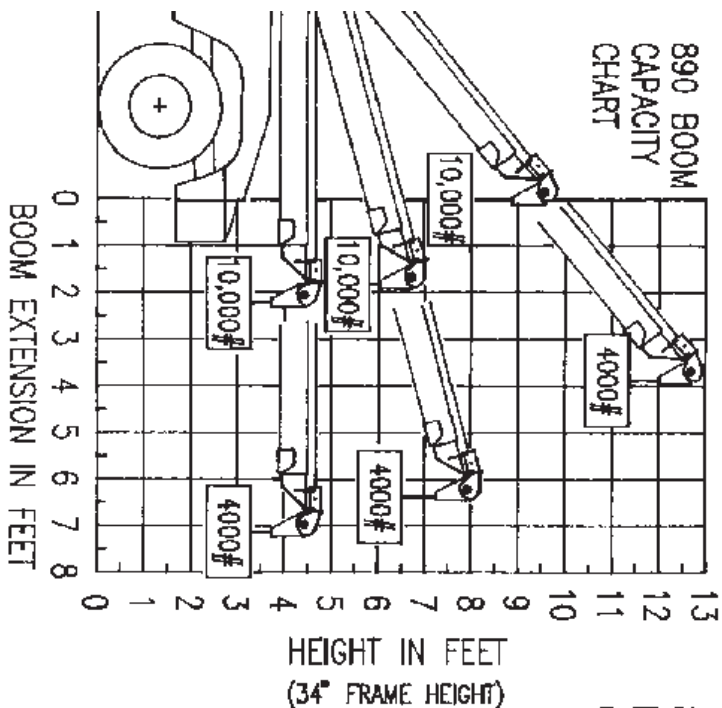

DRIVERS'S LOG BOOK

I hereby certify that I have read this entire manual and that I understand the instructions given for safety, operation and maintenance of the Vulcan 896.

Driver's Name	Date
1.	
2.	
3.	
4.	
5.	
6.	
7.	
8.	
9.	
10.	
11.	
12.	
13.	
14.	
15.	



Miller Industries Towing Equipment Inc.
8503 Hilltop Drive • Ooltewah, Tennessee 37363 • (423) 238-7227
www.millerind.com