

CHEVRON



OWNER'S MANUAL

1014 SERIES

INSTALLATION, OPERATION, MAINTENANCE & PARTS

**NOTE: MANUAL including SPECIFICATIONS, subject to change without notice.
All ratings specified are based on structural factors only,
not vehicle capacities or capabilities.**

CHEVRON

Carriers & Wreckers
7320 W. Market Street
Mercer, PA 16137
Phone (724) 981-7500 • FAX (724) 981-4425
Toll Free (800) 886-6400
<http://www.chevroninc.com>

9/05

LIMITED WARRANTY

CHEVRON, INC., ("Chevron"), warrants to the original purchaser that each new Chevron product will be free from defects in material and workmanship for a period of twelve (12) months from date placed in service. The purchaser must promptly notify Chevron in writing of any failure in material or workmanship. In no event shall Chevron accept such notification later than twelve (12) months from date placed in service.

Chevron's obligation under this warranty, statutory or otherwise, is limited to the repair or replacement at the Chevron factory, or at a point designated by Chevron, of such part or parts as shall appear upon inspection by Chevron to be defective in material or workmanship. New or remanufactured parts will be used for any replacement at Chevron's option. This warranty is not transferable. This warranty does not obligate Chevron to bear the cost of labor or transportation charges in connection with the repair or replacement of any parts found to be defective, nor shall it apply to a product upon which repairs or alterations have been made unless authorized by Chevron.

EXCEPT AS EXPRESSLY SET FORTH IN THIS WARRANTY, CHEVRON MAKES NO OTHER WARRANTY, EXPRESS OR IMPLIED, AND HEREBY DISCLAIMS ALL OTHER WARRANTIES INCLUDING, BUT NOT LIMITED TO, THE IMPLIED WARRANTIES OF MERCHANTABILITY AND FITNESS FOR A PARTICULAR PURPOSE. Chevron shall in no event be liable for claimed downtime, claimed loss of profits or good will, or any other special, incidental, indirect, or consequential damages concerning or relating to any product or parts, whether based on negligence, strict liability, breach of contract, breach of warranty, misrepresentation or any other legal theory, regardless of whether the loss resulted from any general or particular requirement which Chevron knew or had reason to know about at the time of sale.

CHEVRON MAKES NO WARRANTY, EXPRESS OR IMPLIED, AS TO THE FINISHED PRODUCTS MANUFACTURED OR SUPPLIED BY ANOTHER MANUFACTURER AND SUPPLIED BY CHEVRON TO PURCHASER, including, but not limited to, any vehicle to which a Chevron product may be affixed or any accessories or wire rope, and CHEVRON EXPRESSLY DISCLAIMS ANY IMPLIED WARRANTIES OR MERCHANTABILITY OR FITNESS FOR A PARTICULAR PURPOSE AS TO SUCH EQUIPMENT OR PRODUCTS. This language shall in no way affect or diminish the rights of the purchaser to rely on such warranties as are extended by such manufacturers or suppliers. Chevron shall, to the extent permitted under applicable law, pass on to the purchaser such manufacturer's or seller's warranty.

Chevron, whose policy is one of continuous improvement, reserves the right to improve its products through changes in design or materials as it may deem desirable without being obligated to incorporate such changes in products previously sold. This warranty is not intended to cover or include the following items, which are set forth by way of example and not limitation:

- A. Normal deterioration of trim, paint, lettering, and appearance items due to wear or exposure to weather, road conditions, road treatments, etc.
- B. Any damage or defect due to accident, misuse, abuse, operation exceeding rated loads, improper or unauthorized repairs, failure to provide reasonable and necessary maintenance, or uses of which the equipment was not designed or intended.
- C. Alterations or modifications that affect performance, operations or reliability.
- D. Normal maintenance parts including, but not limited to, wear pads, bushings, wire rope, mudflaps, fenderettes, light bulbs, hydraulic oil, filters, and tow sling belts.

IT IS EXPRESSLY UNDERSTOOD THAT CHEVRON MAKES NO IMPLIED WARRANTY THAT CHEVRON PRODUCTS SHALL BE FIT FOR THE PURPOSE OF LIFTING OR MOVING PEOPLE OR FOR ANY OTHER IMPROPER USE.

Section V - PARTS
DIRECT MOUNT TANDEM PUMP

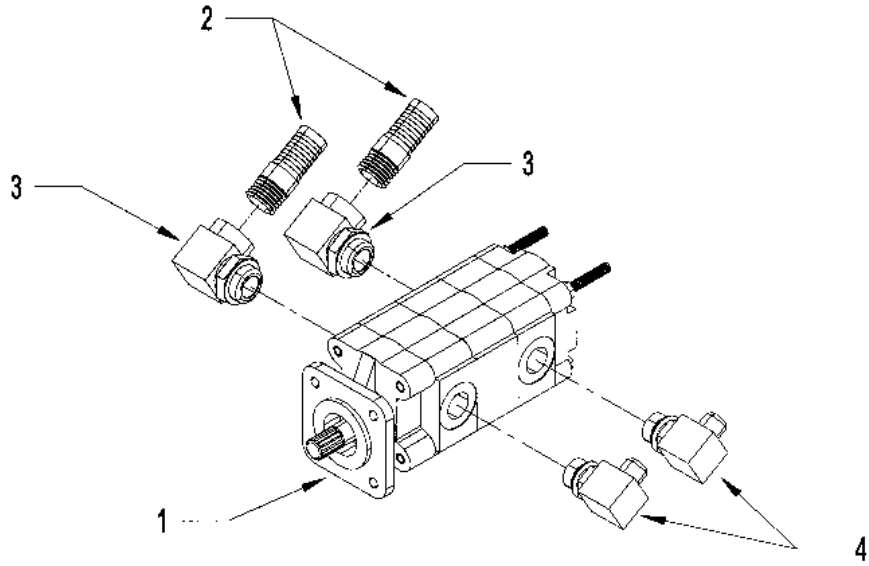

REF	PART #	DESCRIPTION	QPU
1	78014	TANDEM PUMP 15 GPM x 15 GPM	1
2	77CH0	1-1/4 x 3 NPT NIPPLE	2
3	77C90	1-1/4 x 90 M-F O-RING ADAPTER 887-554-20	2
4	77C91	1 M O-RING x 3/4 MJIC x 90	2

Section V - PARTS
1014 MODULAR BOX COMPONENTS

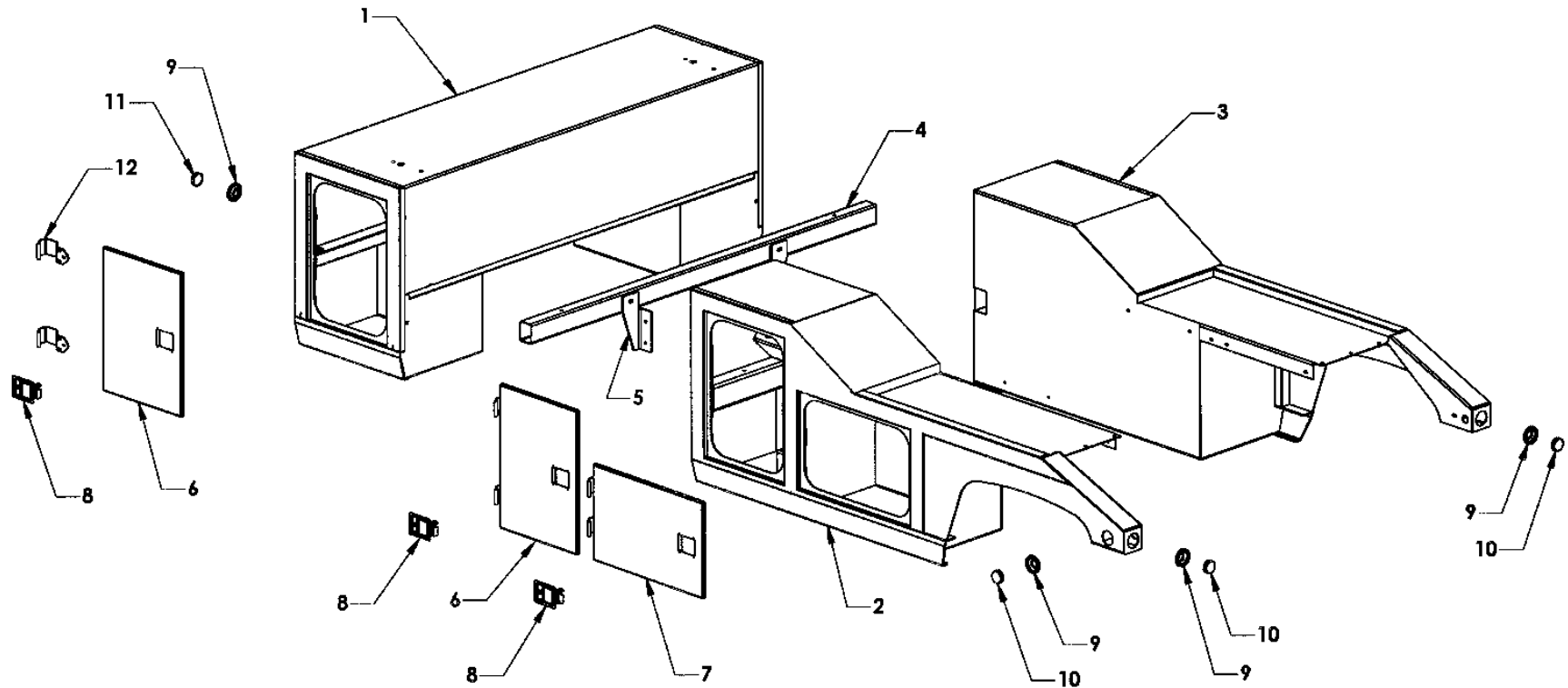

Section V - PARTS**1014 MODULAR BOX COMPONENTS**

REF	PART #	DESCRIPTION	QPU
1	5469028	28 INCH TUNNEL BOX	1
2	5464120L	MODULAR BOX - DRIVER SIDE 120 CA	1
	5464108L	MODULAR BOX - DRIVER SIDE 108 CA	1
3	5464120R	MODULAR BOX - PASSENGER SIDE 120 CA	1
	5464108R	MODULAR BOX - PASSENGER SIDE 108 CA	1
4	54650	MODULAR BOX FRONT CROSSMEMBER	1
5	54655L	CROSSMEMBER MOUNTING BRACKET - LEFT	2
	54665R	CROSSMEMBER MOUNTING BRACKET - RIGHT	2
6	54660	FRONT DOOR	4
7	54680	REAR DOOR - 120 CA	2
	54670	REAR DOOR - 108 CA	2
8	54658	ROTARY PADDLE LATCH	6
9	93150	MARKER LIGHT GROMMET	6
10	93100R	RED REFLECTIVE MARKER LIGHT	4
11	93100A	AMBER REFLECTIVE MARKER LIGHT	2
12	54635	DOOR HINGE	12

Section V - PARTS
1014 SUBFRAME COMPONENTS

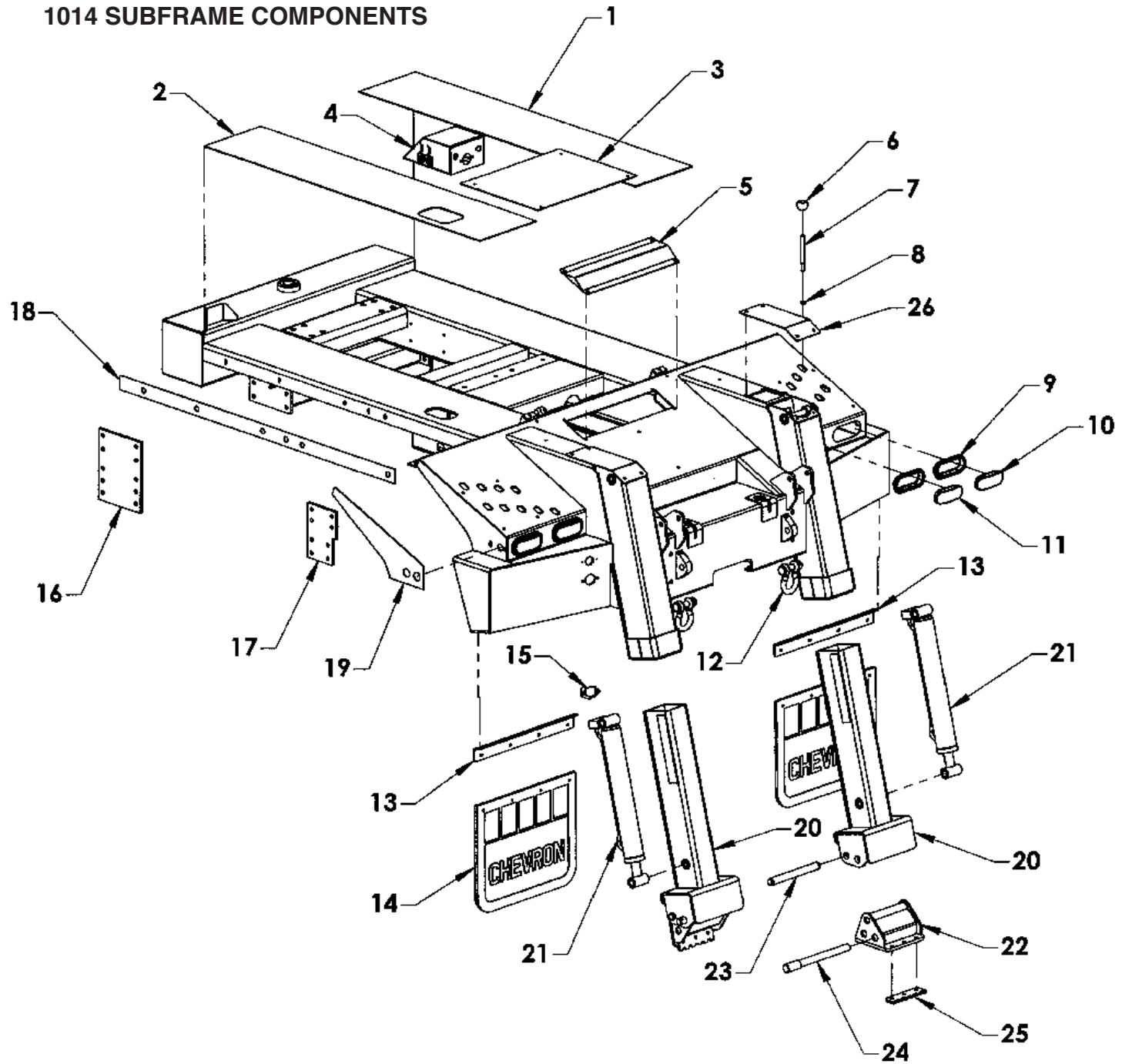

Section V - PARTS
1014 SUBFRAME COMPONENTS

REF	PART #	DESCRIPTION	QPU
1	261191	BRIGHT ALUMINUM DECK PLATE - RIGHT	1
2	261192	BRIGHT ALUMINUM DECK PLATE - LEFT	1
3	261193	BRIGHT ALUMINUM DECK PLATE - MIDDLE	1
4	A70500	GLAD HAND BOX	1
5	51141	REAR ACCESS COVER	1
6	7A211	CONTROL KNOB	14
7	7A165	CONTROL HANDLE	14
8	83421	5/8 JAM NUT	14
9	92650	TAIL LIGHT GROMMET	4
10	92600R	TAIL LIGHT	2
11	95600	BACKUP LIGHT	2
12	84716	6-1/2 TON SHACKLE AND SCREW PIN	2
13	26285	MUDFLAP BRACKET	2
14	A1070	MUDFLAP 24 x 21	2
15	98400	TOW LIGHT SOCKET	1
16	26324	FRONT MOUNTING BRACKET	2
17	26325	MIDDLE MOUNTING BRACKET	2
18	54602	RUBBER GASKET	2
19	54603	RUBBER GASKET	2
20	262620	INNER STABILIZER TUBE	2
21	72190	STABILIZER CYLINDER	2
22	262630	STABILIZER POD	2
23	262637	STABILIZER POD PIVOT PIN	2
24	262638	STABILIZER POD POSITION PIN	2
25	6961413	CLEAT	2
26	262618	ACCESS COVER PLATE	2

Section V - PARTS
1014 RECOVERY BOOM COMPONENTS

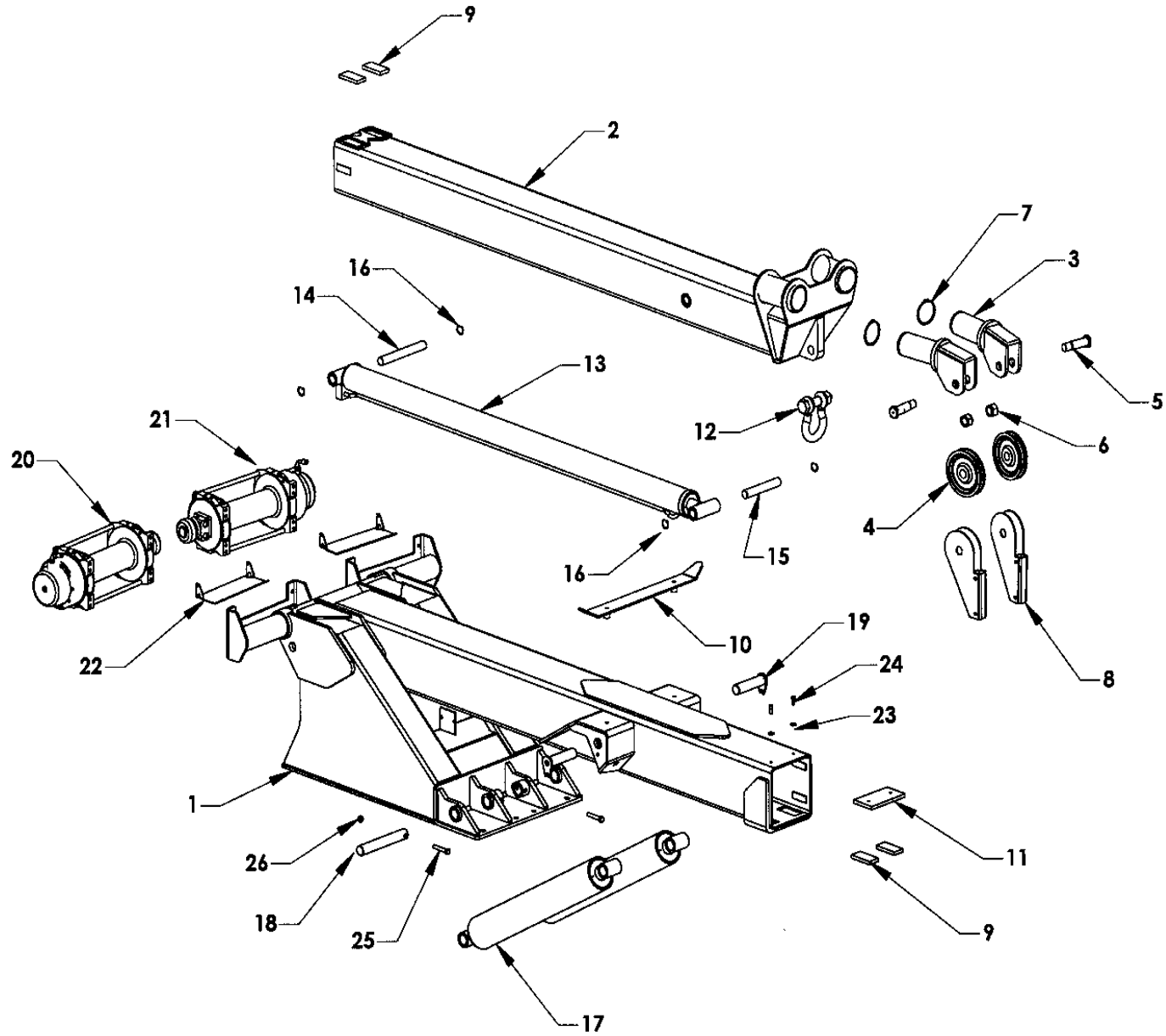

Section V - PARTS

1014 RECOVERY BOOM COMPONENTS

REF	PART #	DESCRIPTION	QPU
1	60610	RECOVERY BOOM 12,000 LB. WINCHES	1
	60620	RECOVERY BOOM 15,000 LB. WINCHES	1
2	63510	INNER BOOM TUBE	1
3	63520	BOOM END SWIVEL	2
4	69140	PULLEY 7 INCH	2
5	61763	PULLEY BOLT	2
6	83812	NUT 1.125-12 NYLON LOCK	2
7	86350E	RETAINING RING 3.50 EXTERNAL	2
8	63530	CABLE FOLLOWER	2
9	63595	WEAR PAD 1/2 x 2 x 4 NYLATRON	2
10	63450	BOOM ANTLER	1
11	63431	SHIM PAD 1/2 x 4 x 7.5 UHMW	1
12	84715	9/12 TON SHACKLE WITH NUT AND BOLT	2
13	7236145	BOOM EXTENSION CYLINDER	1
14	63545	PIN 1.230 x 9.812	1
15	63435	PIN 1.230 x 7.562	1
16	86125 I	RETAINING RING 1.25 INTERNAL	4
17	7236144	BOOM LIFT CYLINDER	2
18	63381	PIN 1.480 x 10.125	2
19	63382	PIN 1.480 x 5.75	2
20	71106L	WINCH 12,000 LB. LEFT	1
	71107L	WINCH 15,000 LB. LEFT	1
21	71106R	WINCH 12,000 LB. RIGHT	1
	71107R	WINCH 15,000 LB. RIGHT	1
22	A9017	TENSIONER KIT FOR 12,000 LB. WINCH	2
	A9024	TENSIONER KIT FOR 15,000 LB. WINCH	2
23	82130	FLAT WASHER 5/16	2
24	81117	CAP SCREW 5/16 x 7/8	2
25	81453	BOLT 1/2 x 3 COARSE THREAD	2
26	83312	NYLON LOCK NUT 1/2 COARSE THREAD	2

Section V - PARTS
1014 UNDERLIFT COMPONENTS

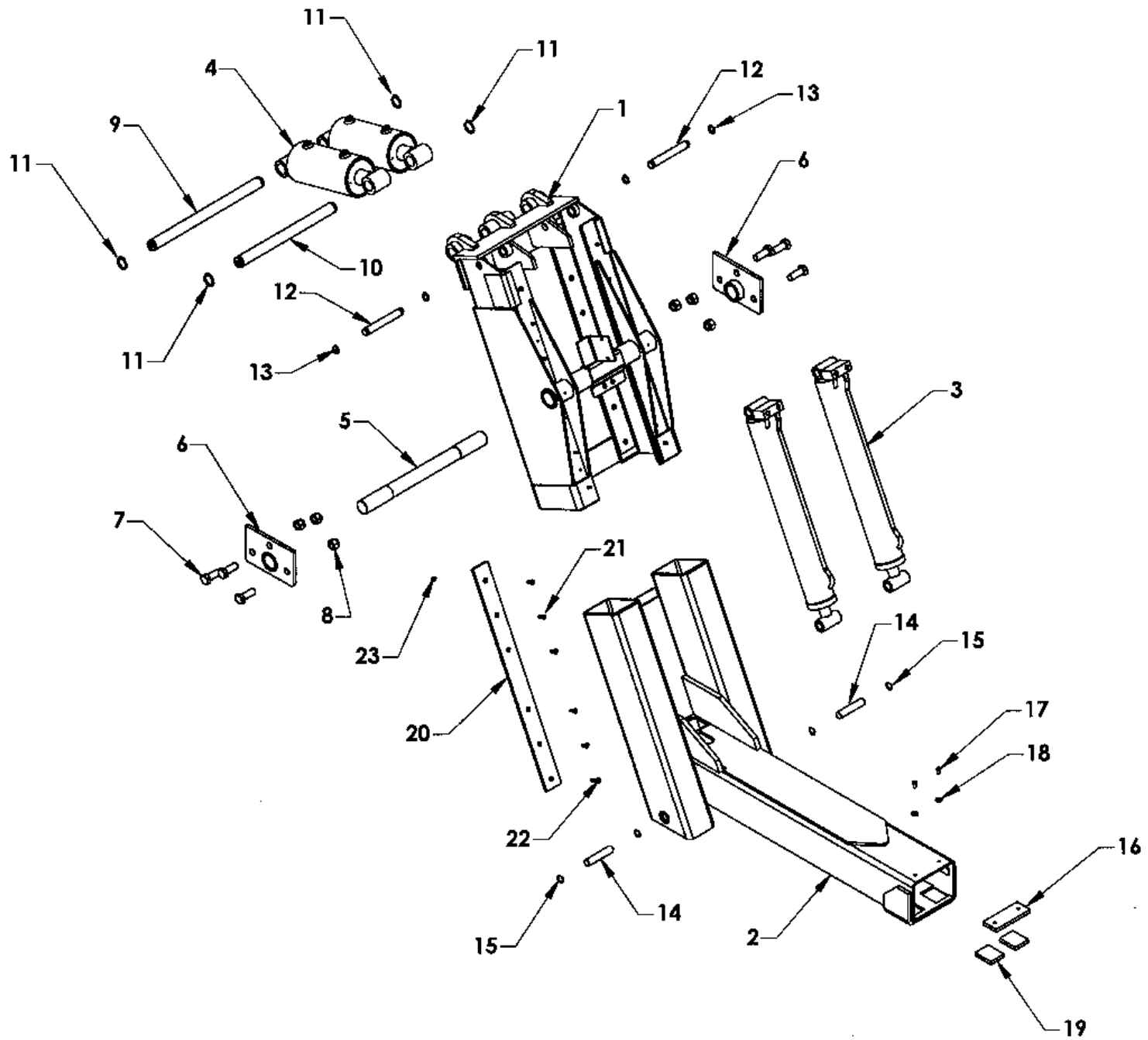

Section V - PARTS
1014 UNDERLIFT COMPONENTS

REF	PART #	DESCRIPTION	QPU
1	68100	SLIDE CARRIAGE	1
2	68200	L-BOOM	1
3	7216142	LIFT CYLINDER	2
4	7216141	POWER TILT CYLINDER	2
5	68125	SLIDE CARRIAGE PIVOT PIN 1.975 x 22.938	1
6	68701	UNDERLIFT MOUNTING BRACKET	2
7	81710	BOLT 7/8 x 2.25 COARSE THREAD	6
8	83611	NUT 7/8 COARSE THREAD	6
9	26306	PIN 1.480 x 20.875 SNAP RING GROOVE	1
10	68123	PIN 1.480 x 10.625 SNAP RING GROOVE	1
11	86150E	RETAINING RING 1.50 EXTERNAL	4
12	64712	PIN .980 x 7 SNAP RING GROOVE	2
13	86100E-1	RETAINING RING 1.00 EXTERNAL	4
14	65714	PIN .980 x 7 SNAP RING GROOVE	2
15	83100I	RETAINING RING 1.00 INTERNAL	4
16	68231	SHIM PAD 1/2 x 2.5 x 6.5	1
17	812A7	BOLT 3/8 x 3/4 COARSE THREAD BUTTON HEAD	2
18	83311	FLAT WASHER 3/8 ID x 9/16 OD	2
19	61735	WEAR PAD 2.5 x 3 NYLATRON	2
20	68130	WEAR STRIP 3.8 x 2.75 x 32.75	4
21	812F0	FLAT HEAD SOCKET CAP SCREW 5/16 x 1	20
22	812F1	FLAT HEAD SOCKET CAP SCREW 5/16 x 1.5	4
23	83120	NYLON LOCK NUT 5/16	24

Section V - PARTS

1014 WHEEL LIFT COMPONENTS AND HOOK-UP ATTACHMENTS

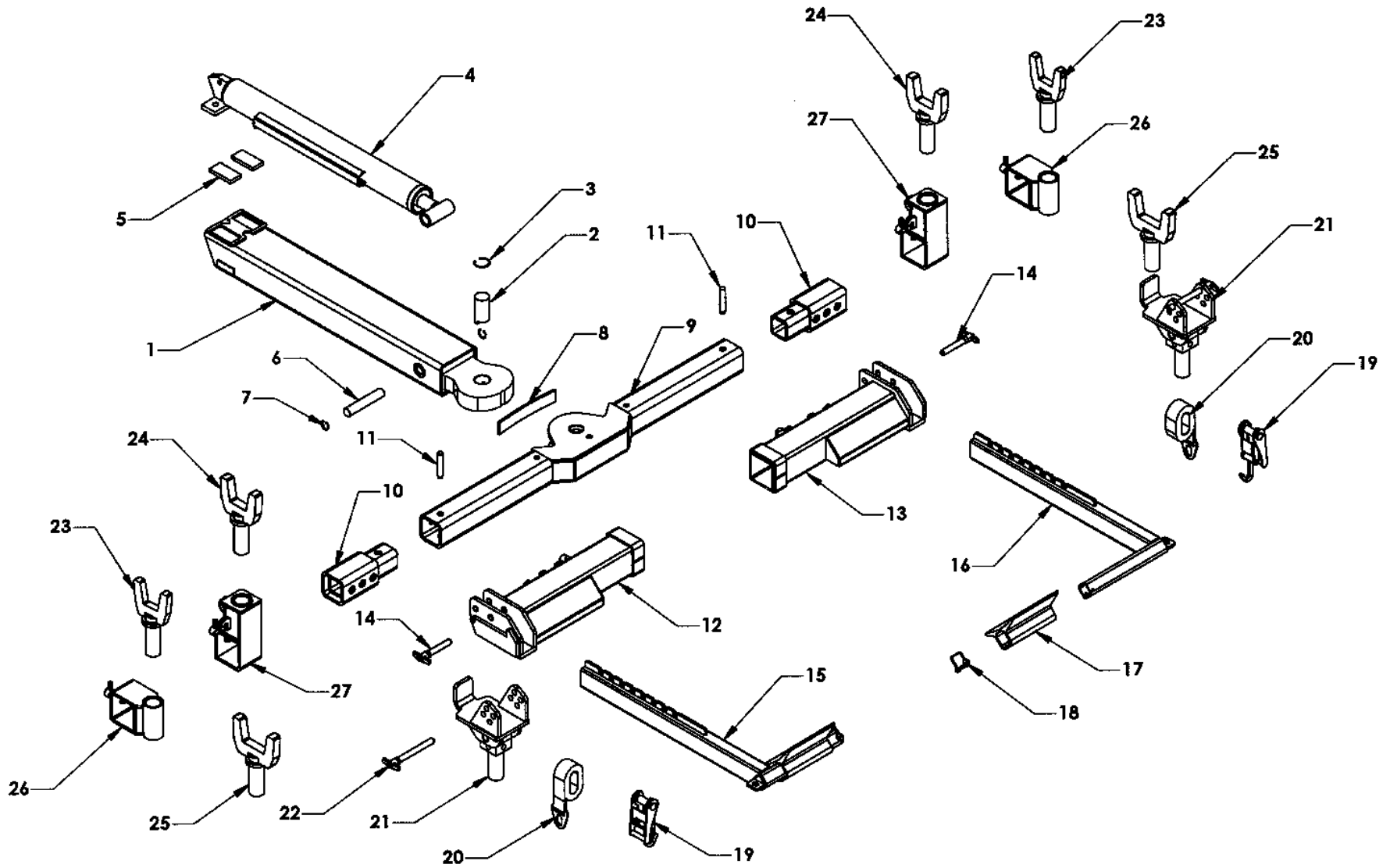

Section V - PARTS

1014 WHEEL LIFT COMPONENTS AND HOOK-UP ATTACHMENTS

REF	PART #	DESCRIPTION	QPU
1	68300	INNERTUBE WELDMENT	1
2	66430	CROSSBAR PIVOT PIN	1
3	86200I	PIVOT PIN RETAINING RING 2 INCH INTERNAL	1
4	7216143	WHEEL LIFT EXTENSION CYLINDER	1
5	63595	WEAR PAD NYLATRON 1/2 x 2 x 4	2
6	68321	PIN 1.230 X 6-5/8	1
7	86125I	RETAING RING 1.25 INTERNAL	2
8	65228	YOKE SPRING 1.75 x 10.875	1
9	68510	CROSSBAR	1
10	68530	CROSSBAR EXTENSION	2
11	68545	CROSSBAR EXTENSION PIN	2
12	66260L	WHEEL GRID - LEFT	1
13	66260R	WHEEL GRID - RIGHT	1
14	84922	T-PIN WITH LANYARD 3/4 x 3.50	2
15	66250L	LEFT L-ARM 6000 LB. CAPACITY	1
	66240L	LEFT L-ARM 4000 LB. CAPACITY	1
16	66250R	RIGHT L-ARM 6000 LB. CAPACITY	1
	66240R	RIGHT L-ARM 4000 LB. CAPACITY	1
17	65245	REMOVABLE WHEEL PAN	2
18	84611	5/16 SAFETY SNAP PIN	2
19	65280A	RATCHET	2
20	65285	WHEEL STRAP	2
21	66320	SPRING SHACKLE ADAPTOR	2
22	84923	T-PIN 3/4 x 6.50	2
23	66290	2 INCH FRAME FORK	2
24	66300	3 INCH FRAME FORK	2
25	66310	4 INCH FRAME FORK	2
26	66280	FORK HOLDER - SHORT	2
27	66330	FORK HOLDER - ELEVATED	2

Section V - PARTS

UNDERLIFT SPADE GROUP

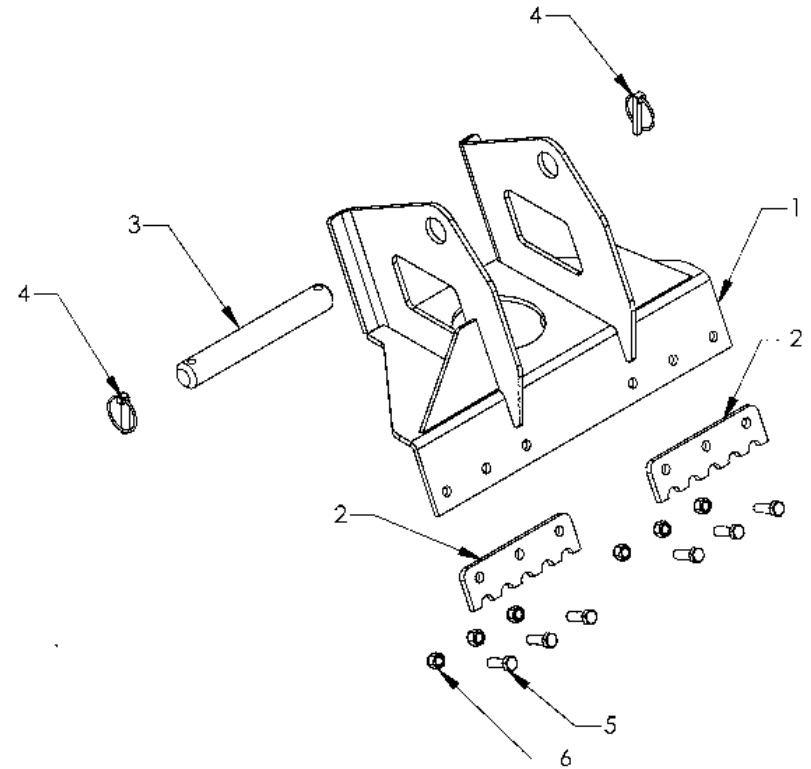

REF	PART #	DESCRIPTION	QPU
	6961410G	SPADE GROUP	
1	6961410	SPADE WELDMENT	1
2	6961413	SPADE TEETH	2
3	6961419	SPADE MOUNTING PIN	1
4	84712	LINCH PIN - 1.50	2
5	81439	BOLT 1/2-13 x 1.75	6
6	883312	NYLON LOCK NUT 1/2-13	6

Section V - PARTS
PINTLE HITCH GROUP

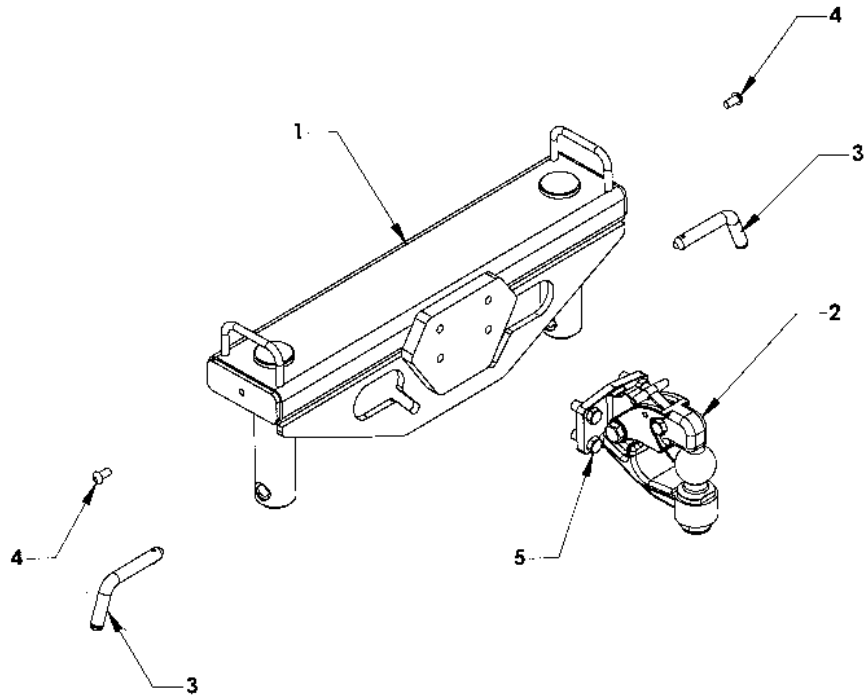

REF	PART #	DESCRIPTION	QPU
	66370G	PINTLE HITCH GROUP	1
1	66370W	PINTLE HITCH WELDMENT	1
2	A3020	TOW BALL PINTLE HITCH	1
3	66378	RETAINING PIN	2
4	812A6	3/8 x 5/8 BUTTON HEAD BOLT	4
	5A220	LANYARD	2
5	81428	BOLT 1/2-13 x 1.25 GRADE 5 OR 8	4
	82310	1/2 LOCK WASHER	4