

CENTURY®

LEGENDARY LEADERSHIP



OWNER'S MANUAL

4024T / T2

INSTALLATION, OPERATION, MAINTENANCE & PARTS

NOTE: MANUAL including SPECIFICATIONS, subject to change without notice
All ratings specified are based on structural factors only,
not vehicle capacities or capabilities.

CENTURY®

Miller Industries Towing Equipment Inc.
8503 Hilltop Drive
Ooltewah, Tennessee 37363

FORM NO. 0500797
REV. A
1 / 99

Phone (423) 238-4171 • FAX (423) 238-5371

PRICE \$25.00

LIMITED WARRANTY

MILLER INDUSTRIES TOWING EQUIPMENT INC., hereinafter referred to as MILLER, warrants to the original purchaser that each new MILLER wrecker or other MILLER products will be free from defects in material and workmanship for a period of twelve (12) months from date placed in service, but in no event shall such warranty period exceed twenty-four (24) months from date of manufacture by MILLER. The purchaser must promptly notify MILLER in writing of any failure in material or workmanship. In no event shall MILLER accept such notification later than twenty-four (24) months from date of delivery or twelve (12) months from date placed in service, whichever is earlier.

MILLER's obligation under this warranty, statutory or otherwise, is limited to the repair or replacement at the MILLER factory, or at a point designated by MILLER, of such part or parts as shall appear upon inspection by MILLER to be defective in material or workmanship. New or remanufactured parts will be used for any replacement at MILLER's option. This warranty is not transferable. This warranty does not obligate MILLER to bear the cost of labor or transportation charges in connection with the repair or replacement of any parts found to be defective, nor shall it apply to a product upon which repairs or alterations have been made unless authorized by MILLER.

EXCEPT AS EXPRESSLY SET FORTH IN THIS WARRANTY, MILLER MAKES NO OTHER WARRANTY, EXPRESS OR IMPLIED, AND HEREBY DISCLAIMS ALL OTHER WARRANTIES INCLUDING, BUT NOT LIMITED TO, THE IMPLIED WARRANTIES OF MERCHANTABILITY AND FITNESS FOR A PARTICULAR PURPOSE. MILLER shall in no event be liable for claimed downtime, claimed loss of profits or goodwill, or any other special, incidental, indirect, or consequential damages concerning or relating to any product or parts, whether based on negligence, strict liability, breach of contract, breach of warranty, misrepresentation or any other legal theory, regardless of whether the loss resulted from any general or particular requirement which MILLER knew or had reason to know about at the time of sale.

MILLER MAKES NO WARRANTY, EXPRESS OR IMPLIED, AS TO THE FINISHED PRODUCTS MANUFACTURED OR SUPPLIED BY ANOTHER MANUFACTURER AND SUPPLIED BY MILLER TO PURCHASER, including, but not limited to, any vehicle to which a MILLER product may be affixed or any accessories or wire rope, and MILLER EXPRESSLY DISCLAIMS ANY IMPLIED WARRANTIES OF MERCHANTABILITY OR FITNESS FOR A PARTICULAR PURPOSE AS TO SUCH EQUIPMENT OR PRODUCTS. This language shall in no way affect or diminish the rights of the purchaser to rely on such warranties as are extended by such manufacturers or suppliers. MILLER shall, to the extent permitted under applicable law, pass on to the purchaser such manufacturer's or seller's warranty.

MILLER, whose policy is one of continuous improvement, reserves the right to improve its products through changes in design or materials as it may deem desirable without being obligated to incorporate such changes in products previously sold. This warranty is not intended to cover or include the following items, which are set forth by way of example and not limitation:

- A. Normal deterioration of trim, paint, lettering, and appearance items due to wear or exposure to weather, road conditions, road treatments, etc.
- B. Any damage or defect due to accident, misuse, abuse, improper or unauthorized repairs, failure to provide reasonable and necessary maintenance, or uses for which the equipment was not designed or intended.
- C. Alterations or modifications that affect performance, operation or reliability.
- D. Normal maintenance parts including, but not limited to, wear pads, bushings, wire rope, mud flaps, fenderettes, light bulbs, hydraulic oil, filters, and tow sling belts.

IT IS EXPRESSLY UNDERSTOOD THAT MILLER MAKES NO IMPLIED WARRANTY THAT MILLER PRODUCTS SHALL BE FIT FOR THE PURPOSE OF LIFTING OR MOVING PEOPLE OR FOR ANY OTHER IMPROPER USE.



Miller Industries Towing Equipment Inc.
8503 Hilltop Drive
Ooltewah, Tennessee 37363

Telephone (423) 238-4171

SERIAL NUMBER

OWNER, USER AND OPERATOR:

Century appreciates your choice of our wrecker for your application. Our number one priority is user safety which is best achieved by our joint efforts. We feel that you can make a major contribution to safety if you, as the equipment owner and operator:

- 1. Comply with Federal, State, and Local Regulations.**
- 2. Read, Understand, and Follow the Instructions in this Manual.**
- 3. Use Good, Safe Work Practices in a Common Sense Way.**
- 4. Only have Authorized and Trained Operators running the Wrecker.**

Also contained in this manual is a Parts Section for your Wrecker. Use of other than Factory or Factory Authorized Parts will render the Warranty void.

TABLE OF CONTENTS



The operator must read and understand all instructions in this manual before operating the wrecker.

It is assumed by CENTURY that the Owner/Operator has a thorough knowledge of the accepted and lawful retrieval and towing methods as dictated by his city, county or state. CENTURY rejects any liability claim that may result from the incorrect or unlawful application of its equipment.

Section I - SAFETY PRECAUTIONS I-1 thru I-15

Section II - SPECIFICATIONS II-1 thru II-5

Section III - OPERATIONAL FUNCTIONS

WRECKER III-1 thru III-5

UNDERLIFT IIIA-1 thru IIIA-3

Section IV - OPERATING INSTRUCTIONS

WRECKER IV-1 thru IV-3

UNDERLIFT IVA-1 thru IVA-24

Section V - MAINTENANCE V-1 thru V-11

MAINTENANCE RECORD V-9 thru V-11

Section VI - PARTS

SUBFRAME ASSEMBLY VI-2 & VI-3

BODY ASSEMBLY VI-4 & VI-5

BOOM ASSEMBLY VI-6 & VI-7

UNDERLIFT & TOWER ASSEMBLY VI-8 & VI-9

UNDERLIFT HYDRAULICS VI-10 & VI-11

TABLE OF CONTENTS (cont'd)

Section VI - PARTS (cont'd)

BOOM ELEVATION HYDRAULICS	VI-12 & VI-13
BOOM EXTENSION HYDRAULICS	VI-14 & VI-15
PUMP, VALVE & FILTER HYDRAULICS	VI-16 & VI-17
WINCH HYDRAULICS & AIR FREE SPOOL	VI-18 thru VI-21
LEFT CONTROL ASSEMBLY	VI-22 & VI-23
RIGHT CONTROL ASSEMBLY	VI-24 & VI-25
WINCH ASSEMBLY - H-800 DOW-LOK	VI-26 & VI-27
REAR SPADE HYDRAULICS	VI-28
HYDRAULIC CYLINDERS	VI-29 thru VI-31
GLAD HAND KIT	VI-32
LIFT ADAPTERS	VI-33
OUTER CROSSTUBE ASSEMBLY	VI-34 thru VI-35
KING PIN & 5TH WHEEL ADAPTER	VI-36
LIGHT KIT	VI-37 thru VI-41

Section VII - INSTALLATION VII-1 thru VII-9

Section VIII - SCHEMATICS

ELECTRICAL	VIII-1 thru VIII-3
HYDRAULIC	VIII-4

Section I - SAFETY PRECAUTIONS

Presented in the interest of safety for all wrecker operators.



NOTICE

You are obligated to operate your wrecker safely. You can be held legally responsible for injuries or damages resulting from unsafe operating practices.

The manufacturer's recommendations for operating this wrecker can help you avoid unsafe practices and their bad consequences. These recommendations are contained in this manual.

Century is not responsible for the results of any unsafe practice of wrecker operators. Furthermore, the division is not responsible for the failure of the wrecker or its accessories resulting from improper maintenance.

The danger from an vehicle does not cease when it is disabled or wrecked. Recovering and towing vehicles can be dangerous, too! The danger threatens wrecker operators and everyone close at hand. As a wrecker operator you must develop an awareness of the hazards involved. You must use every safeguard within reason to prevent injuries.

For each step in operating your wrecker develop the habit of asking yourself if it is safe to proceed. Carefully check all rigging (especially snatch blocks) before starting a heavy lift or pull.

We cannot warn you of all the possible dangers you will encounter. But we will tell you of the most common hazards we know about. Learn them well.

Section I - SAFETY PRECAUTIONS (cont'd)

- 1.1 Improper use of this equipment can be dangerous! Incorrect operation can result in bodily injury to the operator and bystanders. Therefore, a thorough understanding of the "operating principles" and "operating instructions" as found in this manual is essential.
- 1.2 Study each job to be done. Apply common sense judgment to assure safety to yourself and bystanders.
- 1.3 Plan ahead. Work safely. Avoid accidental damage and injury. If an accident or fire does occur, react quickly with the tools and skills at hand. Know how to use a first aid kit and a fire extinguisher - and where to get assistance.
- 1.4 Read and understand the following instructions.



1. READ THE MOUNTING / OPERATING / MAINTENANCE MANUAL FOR WARNINGS AND PRECAUTIONS.
2. NEVER TAKE ANYTHING FOR GRANTED. DON'T ASSUME THAT EVERYTHING IS ALL RIGHT AT THE START OF WORK TODAY JUST BECAUSE EVERYTHING SEEMED ALL RIGHT AT THE END OF WORK YESTERDAY. BEFORE BEGINNING OPERATION, THOROUGHLY INSPECT THE ENTIRE WRECKER TO BE SURE IT IS IN GOOD OPERATING CONDITION.
3. VISUALLY INSPECT THE WRECKER FOR EVIDENCE OF PHYSICAL DAMAGE, SUCH AS CRACKING, BENDING, OR DEFORMATION OF PLATES OR WELDS. INSPECT CAREFULLY FOR CRACKING OR FLAKING OF PAINT, WHICH MAY INDICATE A DANGEROUS CRACK IN THE STRUCTURE BENEATH. DO NOT OPERATE UNTIL REPAIRS ARE MADE.
4. LOOSE OR MISSING HARDWARE, BOLTS, NUTS, AND PINS SHOULD BE PROPERLY TIGHTENED OR REPLACED WITH MANUFACTURER'S SPECIFIED HARDWARE.
5. CHECK FOR FLUID LEAKS. HYDRAULIC SYSTEM LEAKS MUST BE CORRECTED BEFORE THE WRECKER IS OPERATED. INSPECT ALL HYDRAULIC HOSES, ESPECIALLY THOSE WHICH FLEX OR

Section I - SAFETY PRECAUTIONS (cont'd)

MOVE IN SERVICE, AND REPLACE IF NECESSARY. SECURE ALL CAPS AND FILLER PLUGS FOR ALL SYSTEMS.

6. YOUR CLOTHING SHOULD BE RELATIVELY CLOSEFITTING.
7. ALWAYS WEAR PROTECTIVE ITEMS SUCH AS SAFETY GLASSES, GLOVES, REFLECTIVE CLOTHING AND SAFETY SHOES.
8. BEFORE OPERATING THE BOOM, REFER TO THE BOOM CAPACITY LABELS ON THE BOOM AND INSIDE OF THE DOOR OF THE CAB AND IN THE SPECIFICATION SECTION OF YOUR OPERATING MANUAL. FOR CHASSIS CAPACITY CONSULT YOUR TRUCK DEALER. NEVER EXCEED MANUFACTURER'S LOAD RATING. THE STIPULATIONS PERTINENT TO THESE RATINGS SHALL ALWAYS BE CAREFULLY OBSERVED.

RATINGS SHOWN ARE BASED ON THE HYDRAULIC, MECHANICAL, OR STRUCTURAL DESIGN OF THE WRECKER RATHER THAN STABILITY. IT IS ALWAYS UNSAFE TO APPLY ANY LOAD WHICH IS GREATER THAN RATED LOAD SHOWN ON THE DATA PLATE.

9. DO NOT USE THIS EQUIPMENT EXCEPT ON SOLID, LEVEL SURFACE WITH STABILIZERS PROPERLY EXTENDED AND TRUCK BRAKES LOCKED.
10. OPERATE ALL CONTROLS SLOWLY AND SMOOTHLY TO AVOID DAMAGE TO WRECKER OR INJURY TO PERSONNEL.
11. DO NOT OPERATE, WALK OR STAND BENEATH BOOM OR A SUSPENDED LOAD.
12. NEVER LIFT LOAD OVER ANYONE.
13. DO NOT USE BOOM TO LIFT PEOPLE.
14. KEEP LOAD WITHIN ONE FOOT OF THE GROUND WHENEVER POSSIBLE.
15. FOR TRAVEL, BOOM MUST BE IN STOWED POSITION AND P.T.O. DISENGAGED.

Section I - SAFETY PRECAUTIONS (cont'd)



ONLY AUTHORIZED AND TRAINED PERSONNEL SHOULD BE PERMITTED TO OPERATE THIS WRECKER UNSUPERVISED.

TRAINED PERSONNEL ARE THOSE WHO HAVE WORKED UNDER EXPERIENCED SUPERVISION AND HAVE PERFORMED ALL WRECKER MANEUVERS, HAVE READ THE MOUNTING, OPERATING AND MAINTENANCE MANUAL, WARNINGS AND PRECAUTIONS, AND UNDERSTAND AND HAVE HAD EXPLAINED TO THEM BY THEIR EMPLOYER THE HAZARDS OF OPERATING THE WRECKER. THEY MUST BE FAMILIAR WITH THE HAZARDS OF OPERATING AT A SITE WHERE ELECTRIC POWER LINES, IRREGULAR GROUND CONTOUR, WATER, ICE, MUD, OR OTHER CONDITIONS CAN INTERFERE WITH ORDINARY CAREFUL OPERATION OF THIS WRECKER.

AN UNTRAINED OPERATOR SUBJECTS HIMSELF AND OTHERS TO DEATH OR SERIOUS INJURY.



**STAND CLEAR
WHILE OPERATING REAR SPADES**



**USE SAFETY CHAINS ON ALL TOWING
AND LIFTING APPLICATIONS**

Section I - SAFETY PRECAUTIONS (cont'd)

SAFETY TIPS



Death or serious injury can occur when working near power lines.

Learn - beforehand - as much about your working area as possible. Be sure that exact locations of overhead power lines, and other obstructions or hazards are known.

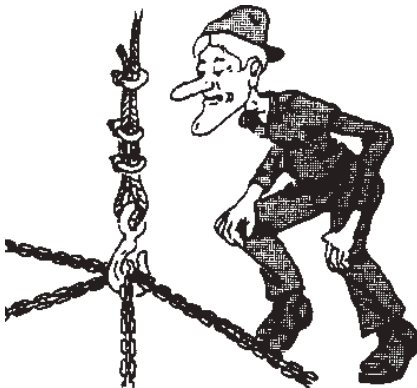
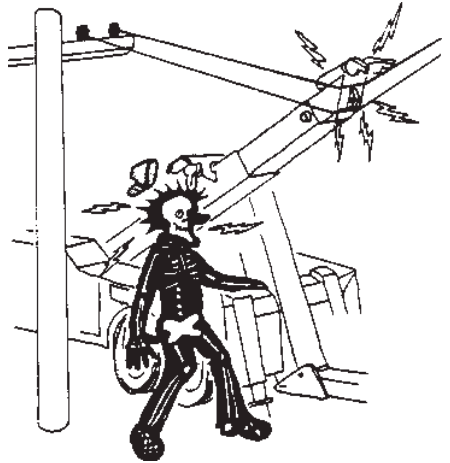

Don't use winch cables with hooks attached by means of cable clips. Use only cables with hooks attached by means of thimbles and machine swaged terminals.

USE CABLE CLIPS ONLY IN THE EVENT OF AN EMERGENCY FIELD TEMPORARY REPAIR.

Use at least three clips spaced 3-4 inches apart and reduce the cable working limit by 20%. U-bolt of the clip should never be around the live or long end of the cable. Replace clips as soon as possible with swaged cable termination.

Section I - SAFETY PRECAUTIONS (cont'd)

SAFETY TIPS

Proper technique for using wire rope clips.

USE CABLE CLIPS ONLY IN THE EVENT OF AN EMERGENCY FIELD TEMPORARY REPAIR.

RIGHT
WAY

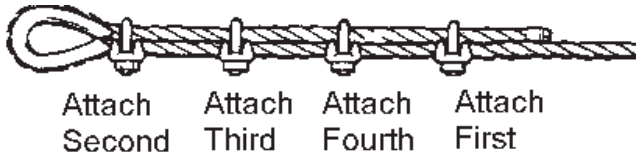

WRONG
WAY

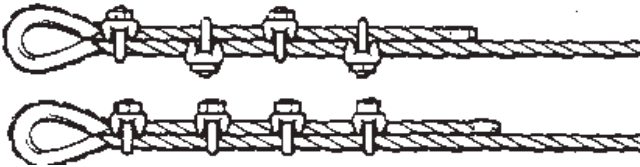

1. Turn back rope length specified in the chart. Apply first clip so U-bolt is no less than the saddle width from the dead end. Tighten nuts evenly and torque as specified.
2. Apply next clip as near loop as thimble will permit. Turn nuts on firm, but do not tighten.
3. Space additional clips as indicated so distance between clips is equal. Tighten all nuts evenly and torque as specified.
4. Apply the initial load and retighten all nuts to recommended torque. Inspect periodically and retighten as needed to the recommended torque.

CLIP SIZE (INCHES)	MINIMUM NUMBER OF CLIPS	AMOUNT OF ROPE TO TURN BACK IN INCHES	TORQUE IN FT.LBS.
3/8	2	6 1/2	45
7/16	2	7	65
1/2	3	11 1/2	65
9/16	3	12	95
5/8	3	12	95
3/4	4	18	130

This table is based on Crosby-Laughlin.

Section I - SAFETY PRECAUTIONS (cont'd)

SAFETY TIPS

Don't use a wrecker that has not been properly maintained. Pay special attention to wrecker mounting bolts, cable condition, and lubrication of moving parts.

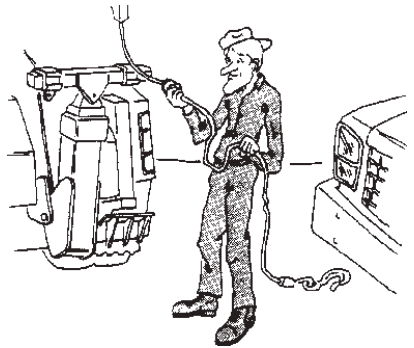
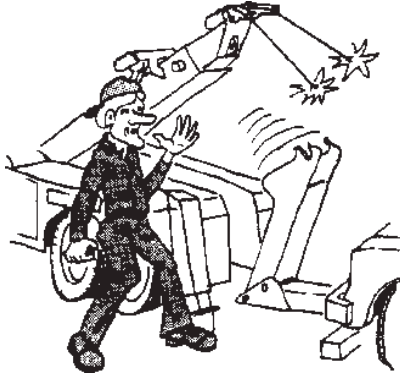

Don't use damaged cables on your wrecker. Become familiar with the various types of cable damage and carefully inspect all cables being used in a recovery operation before starting to pull.

Always use two safety chains when towing all vehicles, regardless of distance.

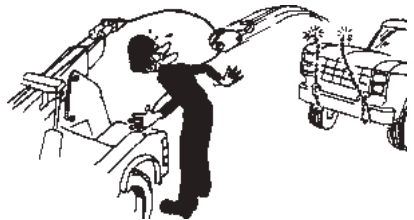
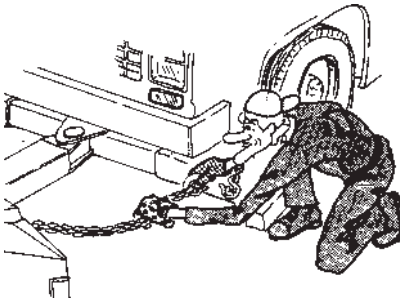

After rigging cables, don't begin pulling without rechecking connections. Make sure that all cables and snatch blocks are securely attached and cannot accidentally pull loose.

Section I - SAFETY PRECAUTIONS (cont'd)

SAFETY TIPS

Don't expect your wrecker to tow loads equal to the wrecker rating. Wrecker ratings apply to loads imposed during recovery, with the wrecker properly stabilized.

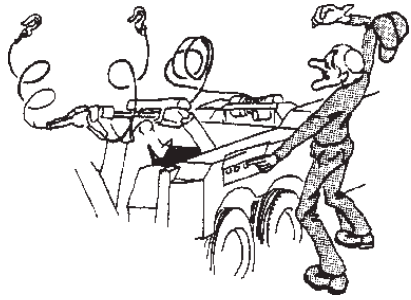
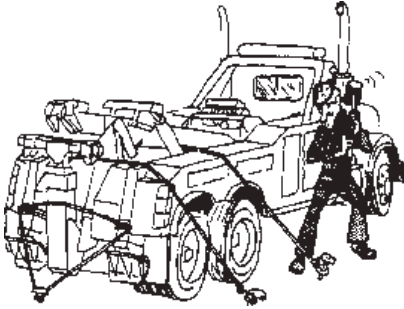

Don't pull a load with your wrecker without making absolutely sure that the winch drum clutch is FULLY engaged.

Don't attempt to recover heavy loads without first estimating the amount of pull that will be required. Rig to keep the estimated amount of pull well within equipment ratings.

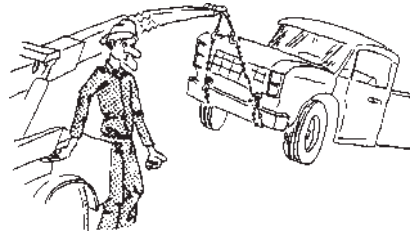
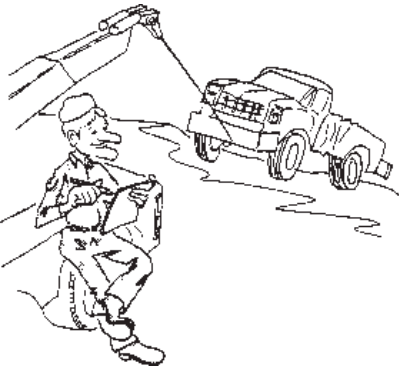

Don't exceed ratings of booms, cables, snatch blocks, or winches. Stay within nameplate ratings. Note that boom ratings decrease significantly as a boom is extended.

Section I - SAFETY PRECAUTIONS (cont'd)

SAFETY TIPS

Don't get under a raised vehicle or load unless it has adequate safety blocks in place.

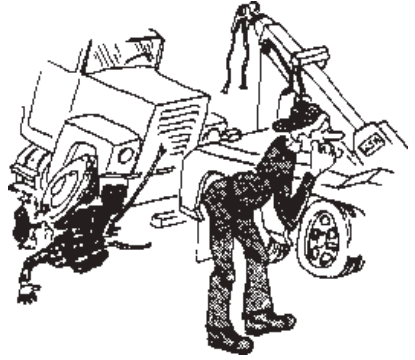

Don't exceed WORKING LIMIT ratings of cable. Use breaking strength ratings only for selecting replacement cable.

Don't tie down the front end of your wrecker for recovery work or heavy lifts. You are apt to damage the truck frame if you do.

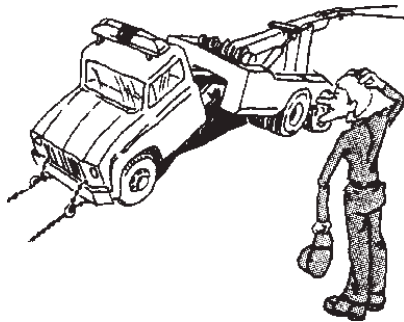

Don't disengage the winch drum clutch while the winch cable is loaded.

Section I - SAFETY PRECAUTIONS (cont'd)

SAFETY TIPS

Don't lower outboard legs or rear spades unless area under them is clear. Pay particular attention to keeping this area clear.

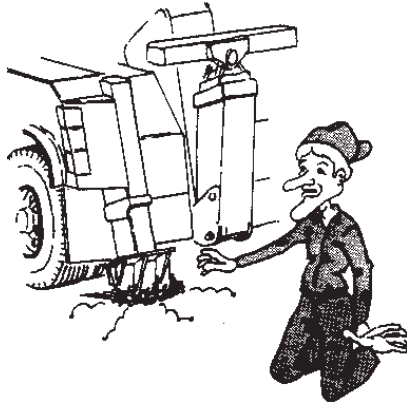
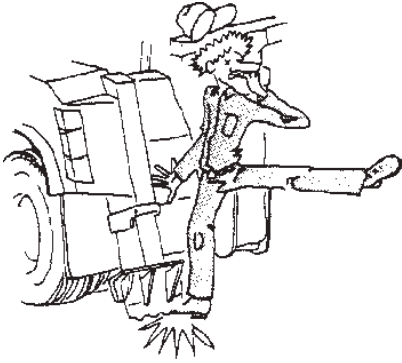

Don't use rear spades on paved surfaces unless you are willing to accept responsibility for possible damage to such surfaces.

Don't permit bystanders in the area while performing recovery work.

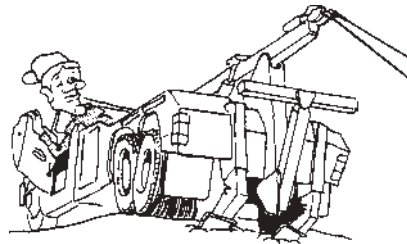
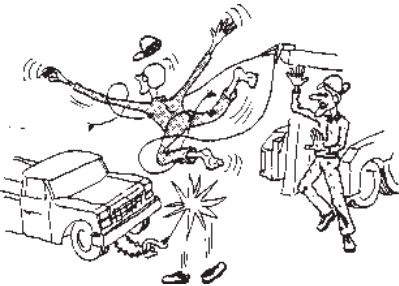

Don't move your wrecker while outboard legs or rear spades are extended.

Section I - SAFETY PRECAUTIONS (cont'd)

SAFETY TIPS

Don't completely unwind all cable from a winch while loaded. Keep AT LEAST five wraps on the drum.

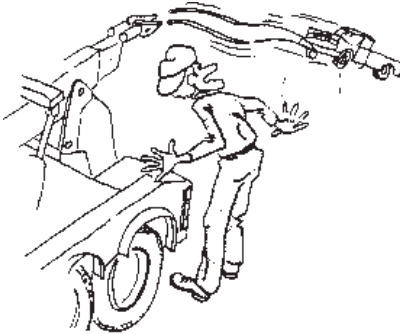

Don't operate your wrecker's engine faster than recommended. Excessive speeds can damage PTO shafts, hydraulic pumps and winches.

Don't rely on anti-theft steering locks. Use special steering wheel clamping device. Rope is commonly used to secure steering wheels, but that is not as reliable as devices designed for this purpose.

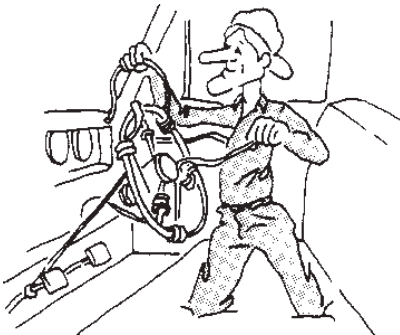

Don't tow a vehicle that reduces the weight on the front wheels of your wrecker more than 40 percent.

Section I - SAFETY PRECAUTIONS (cont'd)

SAFETY TIPS

Don't use towing forks that are not of proper size for pick-up requirements.

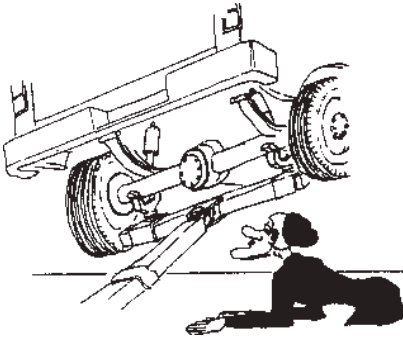

After you have hooked up a vehicle for towing, don't start the tow until you have double checked the hook-up, installed safety chains and released the parking brakes on the towed vehicle.

Don't travel with the wrecker PTO engaged. Engage it only while operating the wrecker controls.

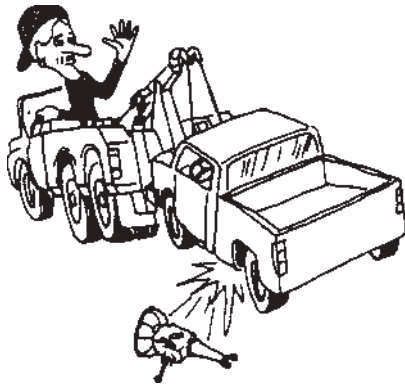
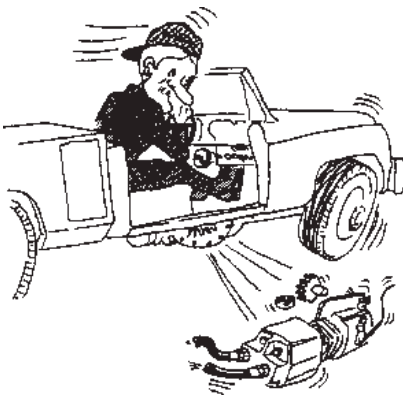

Don't tow a vehicle on its drive wheels unless steps have been taken to protect its transmission and differential. Follow the recommendations of the vehicle manufacturer. As an alternative, use a towing dolly.

Section I - SAFETY PRECAUTIONS (cont'd)

SAFETY TIPS

Don't tow a vehicle on its front wheels if they are damaged.

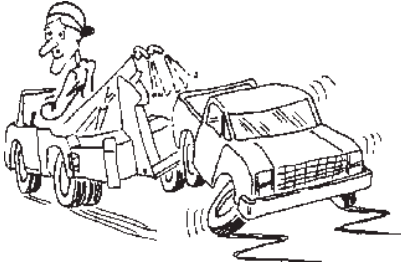

Don't tow a vehicle on its front wheels unless the steering wheel is secured with the front wheels straight ahead.

Don't tow a vehicle at night without proper signal lights on the towed vehicle and the wrecker.

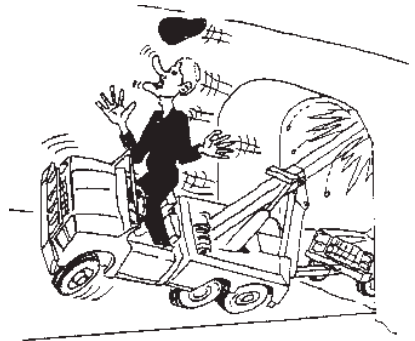
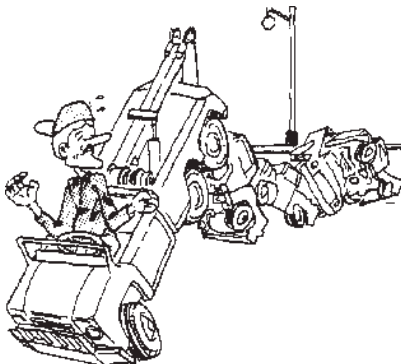

After rigging cables, don't begin pulling without rechecking connections. Make sure that all cables and shatch blocks are securely attached and cannot accidentally pull loose.

Section I - SAFETY PRECAUTIONS (cont'd)

SAFETY TIPS

Don't move wrecker or extend boom where overhead power lines may be encountered.

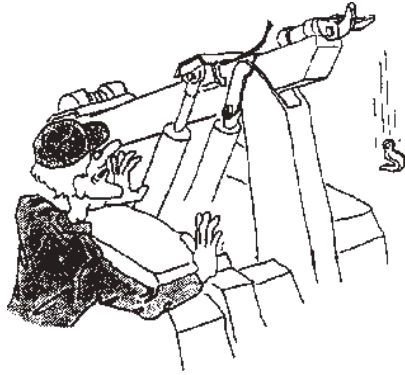
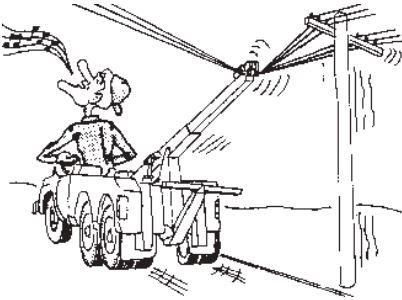

Don't continue to wind in winch cable after the hook is against the boom end.

SAFE TOWING

There are two key factors in safe towing:

1. Have enough front axle weight for safe steering.
2. Avoid excess rear axle weight.

The issue here is safety. Unsafe steering may cause a serious accident. It is recommended that a safe steering formula that maintains at least 50 percent of the UNLADEN (unloaded) front axle weight, for towing, be used.

The formula is expressed as follows: $ML = .5FAW \times WB/OH$
where:

- ML = maximum lifted load for safe steering.
FAW = unladen (unloaded) weight at front axle.
WB = wheel base or distance between the center of the front axle to the center of the rear axle(s).
OH = overhang or distance from the center of the rear axle(s) to the lift point of the towing device.

Section I - SAFETY PRECAUTIONS (cont'd)

SAFE TOWING

To use the formula, multiply the unladen weight at the front axle by .5. Multiply the result by the wheel bases. Then, divide that result by the overhang. So, you should calculate the maximum lifted load for each tow truck, using this formula, post those limits in the truck and instruct each driver to strictly observe those limits.

You should also observe gross vehicle weight ratings (GVWR), gross axle weight ratings (GAWR), and the towing equipment ratings.

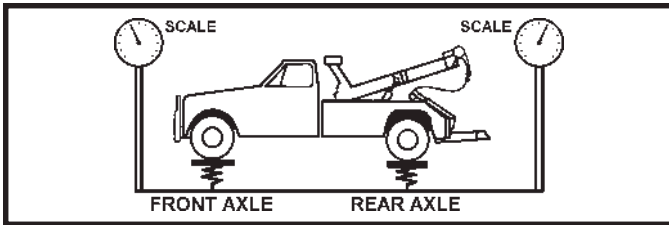

Unladen weights at front and rear axles.

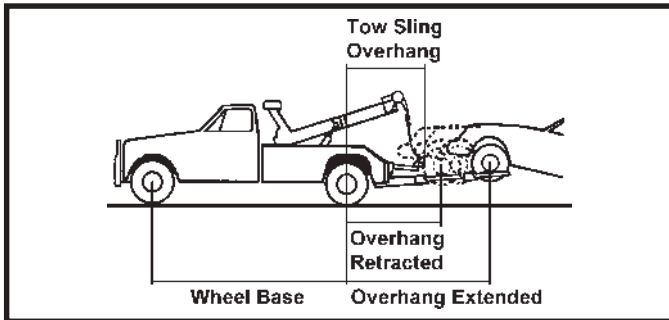

Wheel base and overhang distances for tow slings and wheel lifts.

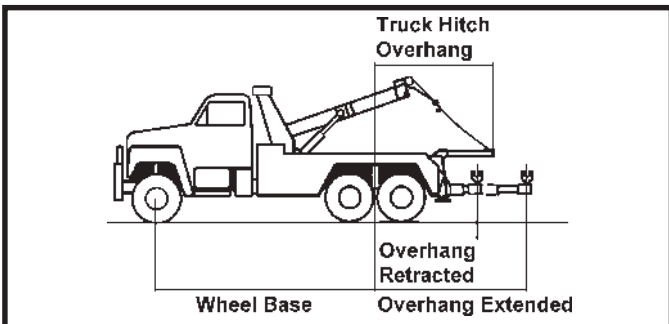

Wheel base and overhang distances for truck hitches and underlifts.

Section II - SPECIFICATIONS

2.1 Federal law requires that the final stage manufacturer, i.e., that person or company installing new equipment on a new chassis, must certify the completed vehicle by obtaining, completing and affixing to the door post on the drivers side of the vehicle, a Certification Label similar to the one shown. See Figure 2.1.

MANUFACTURED BY: _____
DATE OF MANUFACTURE _____ mo _____ yr
INCOMPLETE VEHICLE MANUFACTURED BY: _____
DATE INC. VEH. MFD. _____ mo _____ yr
GVWR _____
GAWR FRONT _____ with _____ tires, _____ rims, @ _____ psi cold _____
GAWR INTERMEDIATE (1) _____ with _____ tires, _____ rims, @ _____ psi cold _____
GAWR INTERMEDIATE (2) _____ with _____ tires, _____ rims, @ _____ psi cold _____
GAWR REAR _____ with _____ tires, _____ rims, @ _____ psi cold _____
THIS VEHICLE CONFORMS TO ALL APPLICABLE FEDERAL MOTOR VEHICLE SAFETY STANDARDS IN EFFECT IN: _____ mo _____ yr
VEHICLE IDENTIFICATION NUMBER: _____
VEHICLE TYPE: _____

FIGURE 2.1

Section II - SPECIFICATIONS (cont'd)

2.2 SERIAL NUMBERS/SPECIFICATION LABELS

Each Century 4024 Wrecker will have a Serial Number/Specification Label mounted on the outer wrecker boom. The label will display the Model Number, Serial Number, Lift and Cable Ratings. See Figure 2.2.



FIGURE 2.2

Section II - SPECIFICATIONS (cont'd)

2.3 SPECIFICATIONS - MODEL 4024

20- Ton hydraulic wrecker with dual 20,000 lb. hydraulic winches, 175' x 9/16" cable, hydraulic spades, 2-stage hydraulic underlift with 120-1/2" reach and lower tilt, 120" C.A. modular body, pylon, lighted tool compartment, and driver's side manual controls.

(a) Winches

4024T	20,000 lb. Worm Drive
4024T3	20,000 lb. Planetary

(b) Cable

Diameter and Length (Each Drum)	9/16" dia. x 175 ft.
Type	6 x 19 Hemp Center, IPS
Working Limit, Each Line	8,500 lbs.

(c) Recovery Boom Specifications

Boom	Rating:
Retracted at 30° (TEMA)	40,000 lbs.
Extended at 30° (TEMA)	15,000 lbs.
Boom Extension	96"
Max. Hook Height (Spades Up)	15' 6"
Reach Past W.L. at Max. Boom Angle	39-3/4"
Max. Boom Angle	40°

(d) Underlift Specifications

Structural Rating:	
Fully Retracted	24,000 lbs.
Fully Extended at Second Stage	12,000 lbs.
Reach:	
Fully Retracted	38"
Fully Extended	102-1/2"
Wheel Lift Capacity	38"
Crossbar Spread W/L Arms	93"
Standard Power Tilt Arc	8"

Section II - SPECIFICATIONS (cont'd)

2.4 CHASSIS RECOMMENDATIONS (MINIMUM)

Minimum GVW	26,500lbs.
Minimum CA Demension	120"
Frame Length (Behind Centerline of Bogie)	42"
RBM Each Frame Rail	1,200,000 in.-lbs.

The outside frame rails of chassis extending behind cab must be free of fuel tanks, air tanks, battery boxes, exhaust stacks, etc.

2.5 STANDARD EQUIPMENT - 4024

- ï 120" C.A. Body
- ï Two 20,000 lb. Hydraulic Winches
- ï 9/16" x 175' Winch Cable, Each Drum
- ï Switch Panel
- ï 6 Pair Lifting Attachments
- ï Air Free Spool
- ï Lighted Tool Compartments with Chain Racks and Tool Holders
- ï Rear Hydraulic Spades
- ï Federal Standard #108 Lighting
- ï Hydraulic Pressure Gauges
- ï Safety Chains
- ï Mud Flaps
- ï Recessed Trailer Air and 7-Way Connectors
- ï Rubber Fenderettes
- ï Variable-Height Light Pylon
- ï Driver's Side Manual Controls
- ï Double Wall Compartment Door with Checks
- ï Cable Tensioners
- ï Two Side Body Work Lights (per side)

Section II - SPECIFICATIONS (cont'd)

2.6 OPTIONAL EQUIPMENT

- ï Wrecker Special Light Bar
- ï Upper and Lower Work Lights
- ï Stainless Steel
- ï Basic Aluminum Package
- ï Air Shift PTO
- ï 138" C.A. Modular Body
- ï Pivoting Spring Adapters
- ï Tunnel Tool Compartment (138" C.A. Body only)
- ï Right Side Manual Controls
- ï Heavy Duty Wheel Lift
- ï Fifth Wheel Adapter
- ï Pintle Hook Attachment
- ï Aluminum Modular Boxes
- ï In-Cab 3-Function Control
- ï Planetary Gear Winches

Note: Specifications Subject to Change without Notification.

Section III - OPERATIONAL FUNCTIONS WRECKER

- 3.1** Your new CENTURY 4024 Wrecker is fully hydraulic. It receives its power by means of a Power Take-Off/Pump combination mounted to the truck transmission. Since the pump is attached to the PTO, no drive line or universal joints are required. See Figure 3.1.

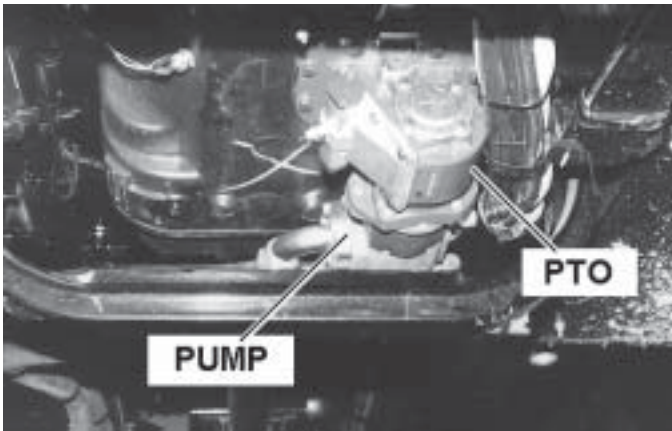

FIGURE 3.1

- 3.2** The Switch Panel is located in the overhead console or beside the drivers seat and controls the light bar, flood lights, auxiliary lights, control station lights and lower work lights. See Figure 3.2.

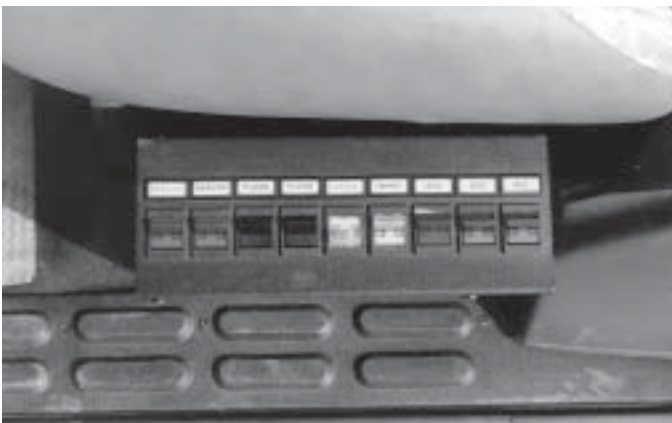

FIGURE 3.2

Section III - OPERATIONAL FUNCTIONS WRECKER (cont'd)

- 3.3** Each function of the Wrecker can be controlled from the Control Station located in the left rear compartment of the body, and the Optional Control Station located in the right rear compartment of the body (when installed). See Figure 3.3.

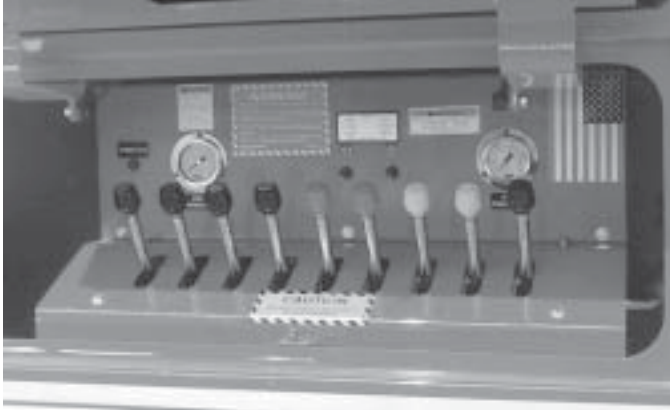

FIGURE 3.3

- 3.4** The Control Handles are clearly marked as to their functions and directions. Movement of the control handles meters the flow of oil through valves to control the speed of each function. Each valve is equipped with a pressure gauge to monitor the hydraulic pressure during the operation.
- 3.5** The Wrecker Boom is elevated and extended by means of double-acting cylinders. The boom can be elevated or extended under either "LOAD" or "NO-LOAD" conditions.
- 3.6** The self-locking winches are powered by hydraulic motors attached directly to the winch drum shafts. See Figure 3.4.

NOTE

**CHECK OIL LEVEL IN WINCHES BEFORE ANY OPERATION.
FILL TO PROPER LEVEL WITH REQUIRED GEAR LUBRICANT.
REFER TO SECTION V - MAINTENANCE AND WINCH MANUAL
FOR PROPER PROCEDURES.**

Section III - OPERATIONAL FUNCTIONS WRECKER (cont'd)

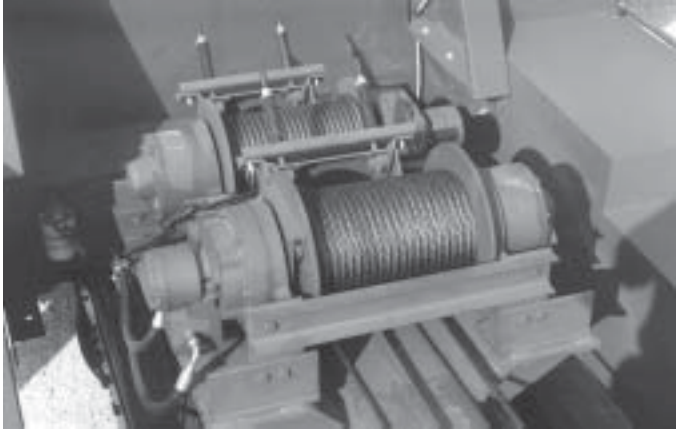

FIGURE 3.4

- 3.7** Before operating your wrecker, remove the Shipping Plugs from the Vent Cap of each worm drive winch (4024T only).
- 3.8** The Winch Air Free Spool Switches are located at the left rear Control Station located in the left rear compartment. When activated, the winch clutch is disengaged and the drum will free spool. Refer to Figure 3.3.
- 3.9** The Rear Spades are for use when lifting heavy loads and are controlled by activating control handles located at the Control Station located in the left rear compartment of the body. See Figure 3.5.

NOTE
THE CONTROL SWITCH ON THE SWITCH PANEL IN THE TRUCK CAB MUST BE ON FOR THE FREE SPOOL SWITCHES TO OPERATE.



**USE SAFETY CHAINS ON ALL TOWING
AND LIFTING APPLICATIONS**

Section III - OPERATIONAL FUNCTIONS WRECKER (cont'd)



FIGURE 3.5

- 3.10** Safety Chains are located at the tailboard of the wrecker subframe. See Figure 3.6.



FIGURE 3.6

Section IIIA - OPERATIONAL FUNCTIONS UNDERLIFT

- 3A.1** Your new Underlift is totally hydraulic. It receives its power by means of a Power Take-Off/Pump combination attached to the vehicle transmission. Since the pump is attached directly to the PTO, no drive line or universal joints are required. Refer to Figure 3.1.
- 3A.2** Each function of the Underlift can be controlled from the Control Station located in the left rear compartment of the body, or from the Hand Held Remote Control Unit. See Figures 3A.1 and 3A.2.

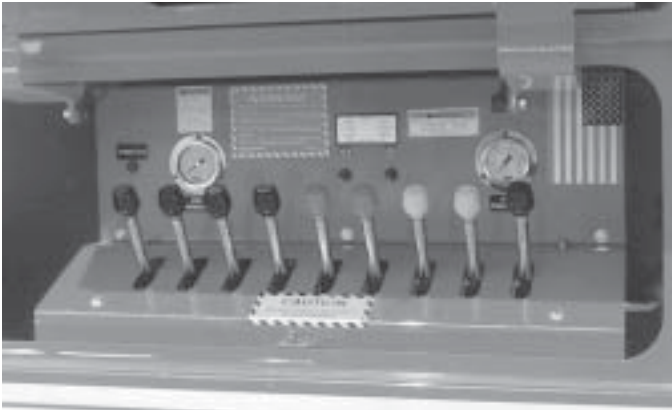

FIGURE 3A.1



FIGURE 3A.2

Section IIIA - OPERATIONAL FUNCTIONS UNDERLIFT (cont'd)

3A.3 The Control Handles are clearly identified as to functions and directions. Movement of the control handles meters the flow of oil through valves to control the speed of each function. Each valve is equipped with a pressure gauge to monitor the hydraulic pressure during the operations.

3A.4 The Underlift is elevated, lowered, extended and retracted by means of double-acting cylinders. The boom can be elevated or extended under either "LOAD" or "NO-LOAD" conditions.

3A.5 REMOTE CONTROL UNIT

- (a) The remote control unit (Power Pal) is located and plugged into the power receptacle in the rear body compartment. See Figure A.2.
- (b) The 8-position Power Pal controls the in and out function, tilt up and down function, and the fold up and down function of the underlift. It also controls the up and down function of the wrecker boom which raises and lowers the complete underlift.
- (c) The Optional 15-position Power Pal also controls the in and out function, the tilt up and down function, and the fold up and down function of the underlift and the up and down function of the wrecker boom which raises and lowers the complete underlift, plus the wrecker boom in and out function, and left & right winch in and out functions.

NOTE

THE CONTROL SWITCH ON THE SWITCH PANEL IN THE TRUCK CAB MUST BE ON FOR THE REMOTE CONTROL UNIT TO OPERATE.

3A.6 Lifting forks and other Underlift Towing and lifting accessories are located in the left hand Tool Box of the wrecker body. See Figure 3A.3.

Section IIIA - OPERATIONAL FUNCTIONS UNDERLIFT (cont'd)



FIGURE 3A.3

Section IV - OPERATING INSTRUCTIONS WRECKER

4.1 For reasons of safety, it is important that the Owner(s) and Operator(s) become thoroughly familiar with the controls and functions of the wrecker before attempting any operation.

4.2 HYDRAULIC WINCHES

- (a) **DO NOT** fasten the winch hook directly to any vehicle.
- (b) **DO NOT** wrap the winch cable around any object.
- (c) **DO NOT** exceed the working limit of the cable.
- (d) **DO NOT** use the winches or cable for the lifting of people.

4.3 PREPARING FOR RECOVERY

- (a) Position wrecker for recovery.
- (b) Reduce truck's engine to idle and apply parking brake. Depress clutch, place transmission in neutral and engage PTO by activating toggle switch located on dash panel in cab. See Figure 4.1.



FIGURE 4.1

Section IV - OPERATING INSTRUCTIONS WRECKER (cont'd)



**NEVER DRIVE TRUCK ON STREET WITH PTO ENGAGED,
THIS CAN CAUSE PUMP FAILURE DUE TO OVER-SPEED
AND OVERHEATING.**

4.4 CABLE PAYOUT

Before operating any control handles, observe the winch cables to make sure they are free and have sufficient slack to allow the boom to extend. If not, pay out cable by using the Cable "IN/OUT" Controls. Maintain tension on cable during payout to avoid fouling line. If manually paying out cable, switch on the Air Free Spool switch and pull cables out to sufficient length for boom extension.

4.5 BOOM ELEVATION & EXTENSION

- (a) Elevate boom to the desired height and angle by use of the Boom "UP/DOWN" Control. Refer to Figure 3.1.

NOTE

**IN THE EVENT OF HYDRAULIC PRESSURE LOSS, THE BOOM
WILL REMAIN AT THE DESIRED ELEVATION DUE TO THE
HOLDING VALVES LOCATED AT THE LIFT CYLINDERS.**

- (b) Extend boom to the desired length by use of the Boom "IN/OUT" Control. Refer to Figure 3.1.



**TO AVOID DAMAGE TO WINCHES, CABLES, OR BOOM,
MAKE CERTAIN WINCH CABLES ARE FREE AND HAVE
SUFFICIENT SLACK TO ALLOW BOOM TO EXTEND.**

Section IV - OPERATING INSTRUCTIONS

WRECKER (cont'd)

4.6 REAR SPADES

- (a) The Rear Spades are for use when lifting heavy loads. See Figure 4.2.



FIGURE 4.2

- (b) The Rear Spades are raised and lowered by activating control handles located at the control station. Refer to Figure 3.1.



**STAND CLEAR OF REAR SPADES
TO AVOID CURUSHING OR INJURY**



**USE SAFETY CHAINS ON ALL TOWING
AND LIFTING APPLICATIONS**

Section IVA - OPERATING INSTRUCTIONS

UNDERLIFT

4A.1 For reasons of safety, it is important that the Owners and Operator(s) become thoroughly familiar with its controls, components and load requirements before attempting any operation.

4A.2 PREPARING TO LOAD VEHICLE

- (a) Align wrecker with vehicle to be towed.
- (b) Reduce truck's engine to an idle, and apply parking brake. Depress clutch, place transmission in neutral and engage PTO by activating toggle switch located on dash panel in cab.



**NEVER DRIVE TRUCK ON STREET WITH PTO ENGAGED,
THIS CAN CAUSE PUMP FAILURE DUE TO OVER-SPEED
AND OVERHEATING.**

4A.3 UNDERLIFT OPERATION

- (a) Each function of the underlift can be controlled using the Hand Held Remote Control Unit or by the control handles at the left control station. Refer to Figures 3A.1 and 3A.2.
- (b) Press "FOLD DOWN" button until Underlift Boom is all the way down. See Figure 4A.1.

Section IVA - OPERATING INSTRUCTIONS UNDERLIFT (cont'd)

4A.3 UNDERLIFT OPERATION (cont'd)

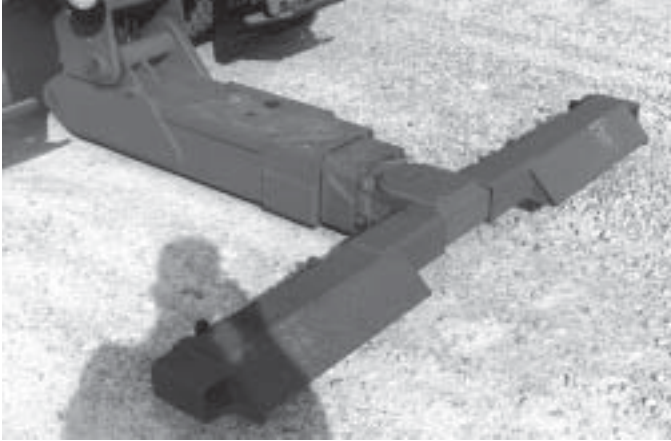

FIGURE 4A.1

- (c) At this point, you must determine which type lift you are going to use for towing: FORK LIFT; SPRING LIFT; AXLE LIFT; TRUCK WHEEL LIFT; etc. The following text covers the methods of operation for each of the above mentioned lifts. Towing attachments are located in the storage compartments on the left hand side of the body. See Figure 4A.2.

Section IVA - OPERATING INSTRUCTIONS UNDERLIFT (cont'd)

4A.3 UNDERLIFT OPERATION (cont'd)



FIGURE 4A.2

4A.4 WHEEL LIFT PROCEDURES

- (a) Loosen "T" handles and extend outer crosstube until tire restraint retainers are just beyond the outer sidewall of the tires on vehicle to be towed.

Section IVA - OPERATING INSTRUCTIONS

UNDERLIFT (cont'd)

4A.4 WHEEL LIFT PROCEDURES (cont'd)

- (b) Press "LIFT DOWN" button and lower boom until underlift just clears ground level.
- (c) Press "LIFT OUT" button and extend boom to maximum stroke and then retract approximately 3".
- (d) Due to position of disabled vehicle it may be necessary to tilt the underlift to obtain the proper position for pickup. This may be accomplished through the use of the "TILT UP" and "TILT DOWN" buttons.
- (e) Disengage PTO and back wrecker until crosstubes are firmly against tires of truck to be towed. See Figure 4A.3. Take wrecker out of gear, apply parking brake and re-engage PTO.



FIGURE 4A.3

- (f) Disengage tire restraint plunger by pulling out and rotating 90°. See Figure 4A.4.

Section IVA - OPERATING INSTRUCTIONS UNDERLIFT (cont'd)

4A.4 WHEEL LIFT PROCEDURES (cont'd)



FIGURE 4A.4

- (g) Insert tire restraint into crosstube and slide in until it is firmly against back of tire.
- (h) Engage plunger and adjust tire restraint until plunger engages appropriate hole in tire restraint. See Figure 4A.5.



FIGURE 4A.5

Section IVA - OPERATING INSTRUCTIONS

UNDERLIFT (cont'd)

4A.4 WHEEL LIFT PROCEDURES (cont'd)

- (i) Repeat procedures (e) through (g) on opposite side of vehicle.
- (j) Take vehicle out of gear and make certain parking brake is off.
- (k) Using the "LIFT UP" button, raise vehicle to desired towing height. See Figure 4A.6.



FIGURE 4A.6

- (l) Insert ratchet strap hook into hole in tire restraint and release safety strap ratchet by releasing lock on ratchet handle.
- (m) With ratchet lock released, pull handle all the way up and pull out desired length of safety strap.
- (n) Position safety strap over top of tire. Make certain that the round portion of the "D" ring is toward rear of wrecker.
- (o) Release ratchet lock and tighten safety strap around tire with ratchet. Ensure ratchet handle is flat against tire restraint as shown in Figure 4A.7.
- (p) Repeat safety strap installation on opposite side of vehicle.

Section IVA - OPERATING INSTRUCTIONS UNDERLIFT (cont'd)

4A.4 WHEEL LIFT PROCEDURES (cont'd)



FIGURE 4A.7



**USE SAFETY CHAINS ON ALL TOWING
AND LIFTING APPLICATIONS**

- (q) Press "LIFT IN" button and pull vehicle in as far as possible while still maintaining a safe turning radius.

NOTE
**MAKE SURE THERE IS ENOUGH SLACK
IN SAFETY CHAINS TO PERMIT TURNING.**

- (r) Stow remote control unit and give hookup a final check before commencing towing operation.

Section IVA - OPERATING INSTRUCTIONS UNDERLIFT (cont'd)

4A.5 SAFETY CHAIN HOOK-UP PROCEDURES

- (a) Extend free end of Safety Chain from storage caddy at top rear of wrecker body. See Figure 4A.8.



FIGURE 4A.8

- (b) Route free end of chain to vehicle to be towed and attach to chassis around axle, leaf springs, or frame. See Figures 4A.9 thru 4A.11.

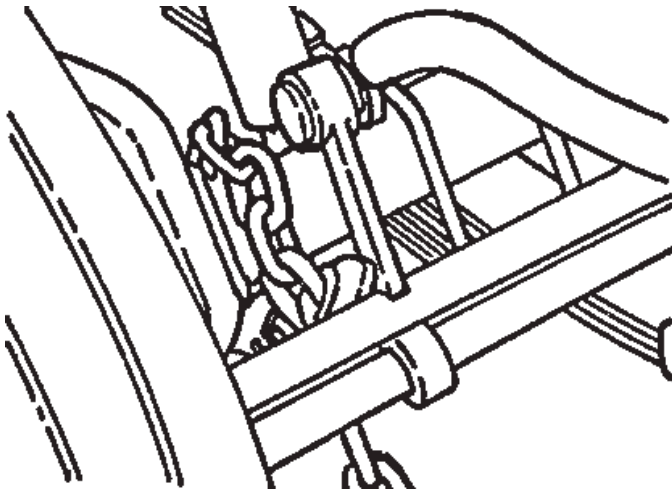

FIGURE 4A.9 AXLE HOOK-UP

Section IVA - OPERATING INSTRUCTIONS UNDERLIFT (cont'd)

4A.5 SAFETY CHAIN HOOK-UP PROCEDURES (cont'd)

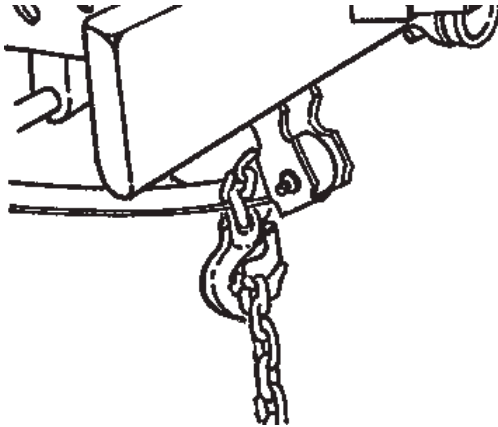

FIGURE 4A.10 LEAF SPRING HOOK-UP

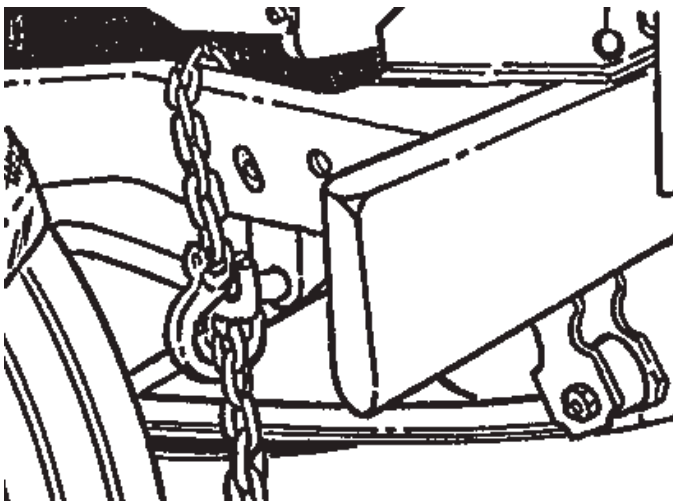

FIGURE 4A.11 FRAME HOOK-UP

- (c) Pull excess chain back to storage caddy. While holding chain securely, feed any excess chain back into storage caddy until enough slack is left in chain for sharp turns.

Section IVA - OPERATING INSTRUCTIONS

UNDERLIFT (cont'd)

4A.6 OUTER CROSTUBE REMOVAL

- (a) Loosen "T" handles and fully extend outer crosstubes.
- (b) Insert a screwdriver or 1/4" diameter rod into stop rod hole located beside "T" handle. See Figure 4A.12.

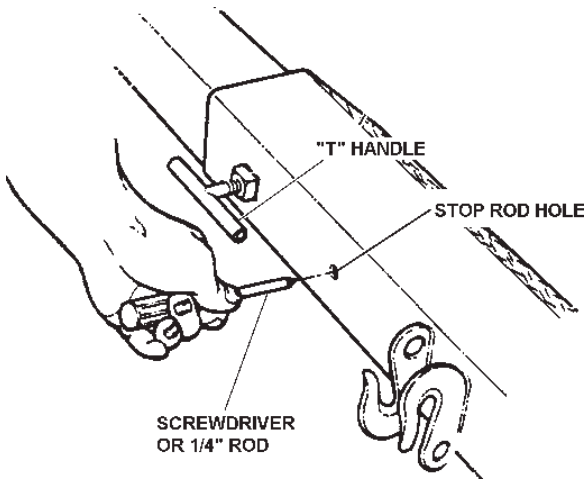

FIGURE 4A.12

- (c) While pushing in to release stop rod, pull outer crosstube off the crossbar.
- (d) To re-install outer crosstubes, simply slide them onto the crossbar. The stop rod will automatically engage when slid all the way on. Tighten "T" handles.

Section IVA - OPERATING INSTRUCTIONS UNDERLIFT (cont'd)

4A.7 AXLELIFT (USING FORKS)

NOTE
STEPS A THRU D ARE NOT REQUIRED IF AXLE IS HIGH ENOUGH TO PERMIT EXTENSION OF CROSSBAR UNDER AXLE WITH FORKS INSTALLED.

- (a) Press "OUT" button and extend the Underlift Boom (without forks attached) until crossbar is centered with front axle of disabled vehicle.
- (b) Press "UP" button and lift truck by front axle until the wheels are high enough to be blocked up.
- (c) Insert blocks under wheels.

NOTE
WHEELS MUST BE BLOCKED HIGH ENOUGH FOR AXLE TO CLEAR FORKS AFTER THEY ARE INSTALLED ON CROSSBAR.

- (d) Press "DOWN" button and lower boom completely.
- (e) Press "IN" button to retract boom until fork adapters can be installed on crossbar.
- (f) Loosen "T" handles on fork adapters and slide adapters onto crossbar.
- (g) Position fork adapters in desired position on crossbar. (fork adapters may be placed in any of (4) positions). Place retaining pins in holes in holes in crossbar and secure with lynch pins. See figures 4A.13 and 4A.14.

Section IVA - OPERATING INSTRUCTIONS UNDERLIFT (cont'd)

4A.7 AXLELIFT (USING FORKS) (cont'd)

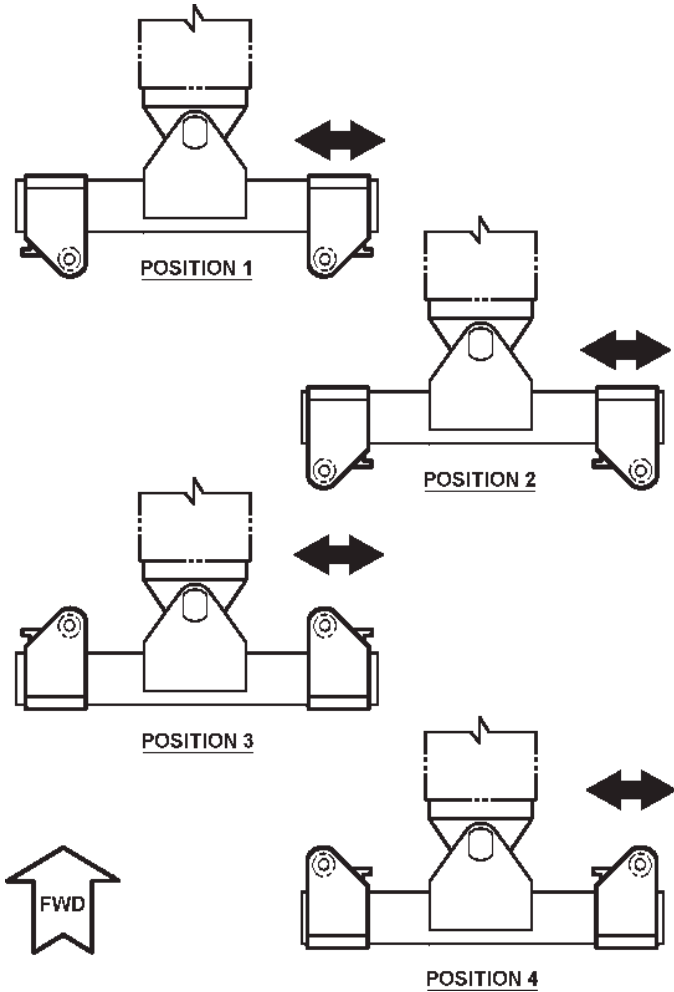

FIGURE 4A.13

Section IVA - OPERATING INSTRUCTIONS UNDERLIFT (cont'd)

4A.7 AXLELIFT (USING FORKS) (cont'd)



FIGURE 4A.14

- (h) Select forks suited for job and install in fork adapters on crossbar. See Figure 4A.15.



FIGURE 4A.15

- (i) Press "OUT" button to extend boom until forks are under axle.

Section IVA - OPERATING INSTRUCTIONS

UNDERLIFT (cont'd)

4A.7 AXLELIFT (USING FORKS) (cont'd)

NOTE
TILT BOOM DOWN, AS REQUIRED, USING "TILT DOWN"
BUTTON UNTIL FORKS WILL CLEAR AXLE.

- (j) Manually adjust fork adapters on crossbar to a point where the forks will contact the axle at the position desired for towing.
- (k) Tighten "T" handles on adapters. Make sure retaining pins at ends of crossbar are secure.

NOTE
RETAINING PINS MUST BE IN PLACE
DURING ALL TOWING APPLICATIONS.

- (l) Press "TILT UP" button and bring forks into contact with axle. If necessary, press "UP" button to raise boom.
- (m) Attach safety chains around axle, crossbar tube and forks as shown in Figure 4A.16.

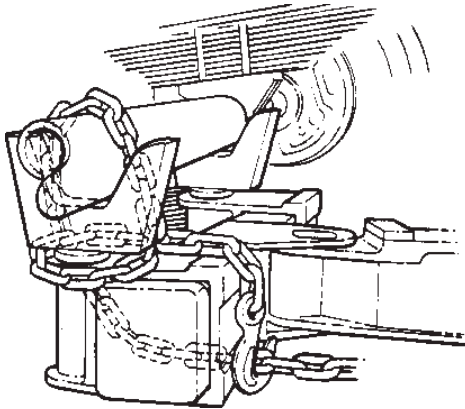

FIGURE 4A.16

Section IVA - OPERATING INSTRUCTIONS UNDERLIFT (cont'd)

4A.7 AXLE LIFT (USING FORKS) (cont'd)

- (n) Press "UP" button to raise vehicle to desired height for towing.
- (o) Remove blocks if previously placed under front wheels.



MAKE NO ATTEMPT TO USE THE FOLD FEATURE OF THE UNDERLIFT BOOM TO RAISE OR PICK UP A LOAD. THE UNDERLIFT FOLD CYLINDER WILL NOT HOLD, BUT WILL LEAK DOWN.

- (p) Press "IN" button and pull vehicle in as far as possible while still maintaining a safe turning radius.



USE SAFETY CHAINS ON ALL TOWING AND LIFTING APPLICATIONS.

**NOTE
MAKE SURE THERE IS ENOUGH SLACK IN SAFETY CHAINS TO PERMIT TURNING.**

- (q) Stow remote control unit and give hookup a final check before commencing towing operation.

Section IVA - OPERATING INSTRUCTIONS

UNDERLIFT (cont'd)

4A.8 SPRING LIFT

- (a) Press "DOWN" button and lower boom completely.
- (b) Loosen "T" handles on fork adapters and slide adapters onto crossbar.
- (c) Position fork adapters in desired position on crossbar. (Fork adapters may be placed in any of four (4) positions). Place retaining pins in holes in crossbar and secure with lynch pins. Refer to Figures 4A.13 and 4A.14.
- (d) Retrieve spring lift brackets from storage and install on fork adapters on crossbar. See Figure 4A.17.



FIGURE 4A.17

- (e) Press "OUT" button and extend boom until spring lift brackets are under front hangers (on some vehicles, the spring brackets may need to be inserted into adapters after extending crossbar behind bumper).
- (f) Manually adjust spring lift brackets on crossbar to a point where the brackets will engage the springs at the front hanger brackets. See Figure 4A.18.

Section IVA - OPERATING INSTRUCTIONS UNDERLIFT (cont'd)

4A.8 SPRING LIFT (con't)

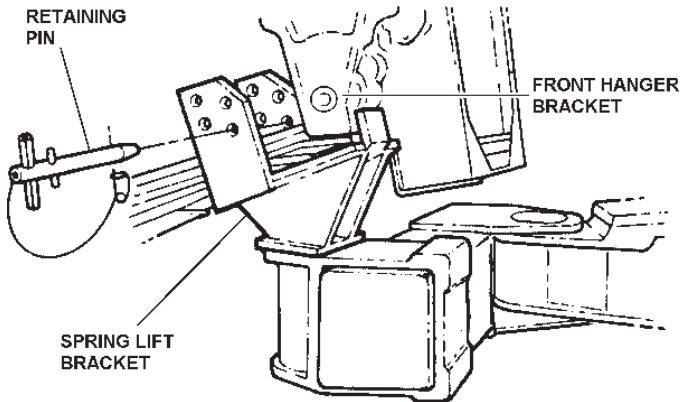

FIGURE 4A.18

- (g) Tighten "T" handles on adapters. Make sure retaining pins at ends of crossbar are secure.
- (h) Press "UP" button and raise boom until brackets are properly seated under springs at front spring hanger brackets.
- (i) Insert retaining pin through lowest unobstructed hole of spring lift bracket and secure with safety pin. Refer to Figure 4A.18.
- (j) Attach safety chains around springs, spring lift brackets and crossbar tube in such a manner as to prevent any movement to front or rear.



**USE SAFETY CHAINS ON ALL TOWING
AND LIFTING APPLICATIONS**

Section IVA - OPERATING INSTRUCTIONS

UNDERLIFT (cont'd)

4A.8 SPRING LIFT (con't)

NOTE
MAKE SURE THERE IS ENOUGH SLACK
IN SAFETY CHAINS TO PERMIT TURNING.

- (k) Press "UP" button and raise vehicle to desired height for towing.
- (l) Using "IN" button, pull vehicle in as far as possible while still maintaining a safe turning radius.
- (m) Stow remote control unit and give hookup a final check before commencing towing operation.

4A.9 KINGPIN ADAPTER (OPTIONAL)

- (a) Install Fork Adapters on crossbar as shown in Figure 4A.19.



FIGURE 4A.19

- (b) Attach Pintle Hook Bracket to fork adapters. Install the two (2) pintle hook bracket retaining pins and tighten "T" handles on fork adapters. See Figure 4A.20.

Section IVA - OPERATING INSTRUCTIONS UNDERLIFT (cont'd)

4A.9 KINGPIN ADAPTER (cont'd)

NOTE
**PINTLE HOOK MUST BE REMOVED FROM PINTLE HOOK
BRACKET FOR KINGPIN ADAPTER APPLICATIONS.**

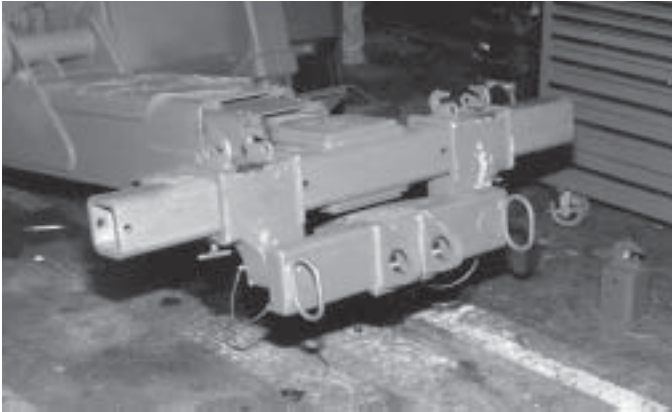

FIGURE 4A.20

- (c) Attach Kingpin Adapter to pintle hook bracket with attaching pin and lock pin. See Figures 4A.21 and 4A.22.

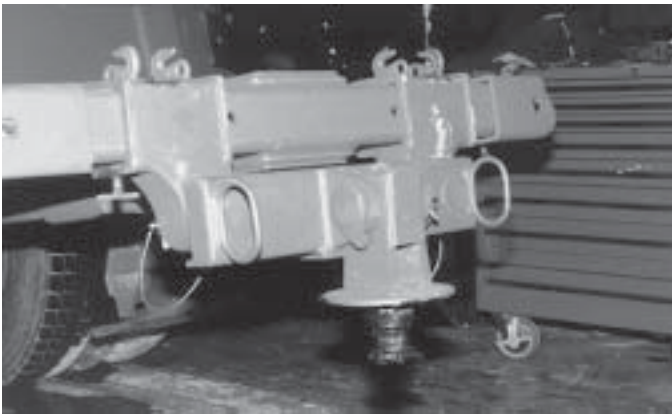

FIGURE 4A.21

Section IVA - OPERATING INSTRUCTIONS UNDERLIFT (cont'd)

4A.9 KINGPIN ADAPTER (cont'd)



FIGURE 4A.22

- (d) Position and align kingpin adapter at proper elevation and extend underlift until adapter engages and locks into fifth wheel on the tractor. Refer to Figure 4A.22.

NOTE
INSPECT FIFTH WHEEL PLATE FOR FATIGUE
AND/OR DAMAGE FROM IMPROPER USE PRIOR TO
USING THIS ATTACHMENT.

- (e) Before lifting vehicle, install two (2) 3/8" GR70 tow chains (MINIMUM REQUIRED). Route chain around frame rails and over crossbar, placing chain between hooks on fork adapters, removing as much slack as possible. As the vehicle is lifted, the load should transfer to the tow chains. See Figure 4A.23.

Section IVA - OPERATING INSTRUCTIONS UNDERLIFT (cont'd)

4A.9 KINGPIN ADAPTER (cont'd)



FIGURE 4A.23

- (f) On tractors with air bag suspensions, you must secure each axle with minimum 5/16" GR70 tow chain to prevent damage to air bags. Route chain around axle on one side, across frame rails and around axle on other side. Refer to Figure 4A.17.
- (g) Secure vehicle with safety chains and inspect for transport.

Section V - MAINTENANCE

5.1 The continued operation of your CENTURY 4024 Wrecker is largely dependent upon strict adherence to a properly scheduled preventive maintenance program. To help you in this program, CENTURY has provided the following information regarding lubrication, preventive maintenance, hydraulic system and safety devices care.

5.2 HYDRAULIC SYSTEM

The importance of absolute cleanliness of the hydraulic system cannot be over stressed. The smallest amount of grit, metal flake or other foreign material in the system can cause extensive damage to pumps, motors and valves. CENTURY has taken every measure to assure that each component and fitting was thoroughly cleaned before your unit was shipped to you. Therefore, servicing of the system should be done with extreme care.

- (a) Before checking oil level in reservoir, wipe away all dirt, grease and grime around filter cap before removing it. Make certain that all containers, funnels and pouring spouts are absolutely clean before filling reservoir.
- (b) When replacing hoses, fittings or other components, clean thoroughly, dismantle and reassemble carefully.
- (c) Failure to observe these precautions, and failure to change the filter element at regular intervals could result in loss of your warranty in the event of failure to certain components.

5.3 LUBRICATION & PREVENTIVE MAINTENANCE

The following general lubrication and preventive maintenance should be performed at least once per month for moderate usage, or more often as required, for heavy usage.

- (a) Inspect, repair or replace any worn, cracked, leaking, otherwise damaged components including, but not limited to, the following:
 - 1. **Hydraulic Hoses and Fittings**
 - 2. **Cables and Fittings**
 - 3. **Cylinders**
 - 4. **Boom End Fittings**
 - 5. **Controls**

Section V - MAINTENANCE (cont'd)

5.3 LUBRICATION & PREVENTIVE MAINTENANCE (cont'd)

6. **Hydraulic Oil Filters**
7. **Oil Reservoir**
8. **Lights and Wiring**
9. **Winches**
10. **Pivot Bearing Surfaces and Pins**

(See Lubrication Charts, page V-9 thru V-11.)

- (b) Check hydraulic oil level in reservoir and fill to center of sight gauge. Refer to 5.4, part (a), SUMMARY OF REQUIRED LUBRICANTS for recommended oils to use.
- (c) Replace hydraulic oil filters after first week of operation, then every three (3) months thereafter.
- (d) Inspect all bolts for tightness and re-tighten as necessary. Vibration and stress may loosen even properly torqued bolts.
- (e) Lubricate all grease fittings on the Wrecker and Underlift weekly including:
 1. **Spade Cylinder Pivots**
 2. **Sheaves (fittings in sheave shafts)**
 3. **Boom End Swivels (fitting top side of boom swivel)**
 4. **Winch Clutches**
 5. **Boom Elevation and Extension Cylinder Pivots**
 6. **Boom Pivot**
 7. **Underlift Pivot**
 8. **Tower Pivot**
 9. **Underlift Tilt Cylinders (each end)**
- (f) All bearing surfaces not equipped with grease fittings should be oiled using SAE 30 oil in a pump can.
- (g) Grease boom slide pads with grease with grease fittings located on top of outer boom at heel end second stage only.

Section V - MAINTENANCE (cont'd)

5.3 LUBRICATION & PREVENTIVE MAINTENANCE (cont'd)

- (h) Check oil level of winches and fill to level of oil plug located in side plate of gear housing Use SAE 140 general purpose gear oil. Lubricate grease fittings on clutches.
- (i) Lubricate winch cables using an oily rag while re spooling onto drum. Other special cable lubricants are available which have better penetrating qualities. Consult your local oil company for a list of these.

5.4 SUMMARY OF REQUIRED LUBRICANTS

(a) Hydraulic Oil

Examples:

1. **Texaco Rando HD 46**
2. **Shell Tellus Oil 46**
3. **Mobil Nuto H46**
4. **Exxon Nuto H46** or Equal

(b) Winch Worm Gear Oil - SAE 140 general purpose gear oil.

Examples:

1. **Humble - Pen-O-Led EP #5**
2. **Phillips - Phillips Worm Gear Oil 140**
3. **Shell - Macona #978**
4. **Sinclair - Pennant EP #6**
5. **Standard - Stanogear #5**
6. **Texaco - Maropa #5**

- (c) **Grease** - Synthetic Fortified such as Drydene SFG.
- (d) **Oil for miscellaneous bearing surfaces** - SAE 30.
- (e) **Cable Oil** - SAE 30 or special cable lubricant.

Section V - MAINTENANCE (cont'd)

NOTE

THERE IS NO PRACTICAL WAY TO DETERMINE THE LIFE EXPECTANCY OF HYDRAULIC HOSES AND OTHER RUBBER COMPONENTS.

WHILE APPEARING TO BE IN EXCELLENT CONDITION, THESE COMPONENTS MAY BE ADVERSELY AFFECTED BY USAGE, WEATHER OR THE PASSING OF TIME.

THEREFORE, IT IS RECOMMENDED THAT ALL RUBBER COMPONENTS, ESPECIALLY HOSES, BE REPLACED EVERY FIVE (5) YEARS REGARDLESS OF APPEARANCE.

5.5 CARE OF HYDRAULICS IN COLD CLIMATE

When the CENTURY Wrecker and Wheel Lift are used in seasonal cold climate regions (+20° F and below), the viscosity of the normally recommended 10W40 oil may increase to the point where it adversely affects hydraulic functions during starting and warm-up.

If this is the case, it will be necessary to change fluids seasonally to maintain maximum system efficiency and life.

Regions subject to continuous sub-zero or arctic climates require special hydraulic fluids. Contact CENTURY or your local supplier for information regarding specific temperature requirements.

NOTE

THE FOLLOWING LUBRICATION REQUIREMENTS SHOULD BE SERVICED MONTHLY.

SERVICE MORE OFTEN IF THE EQUIPMENT IS USED FREQUENTLY.

Section V - MAINTENANCE (cont'd)

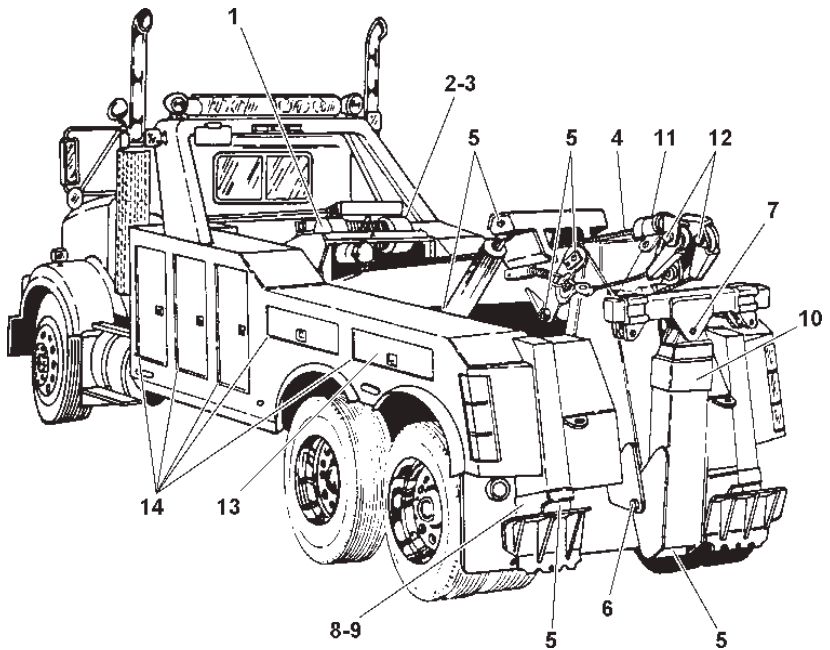

LUBRICATION CHART

5.6 LUBRICATION

1. Winch Oil Level - Fill to oil plug level inside of housing with SAE 140 general purpose gear oil.
2. Hydraulic Reservoir - Fill to center of sight gauge with recommended hydraulic fluid.
3. Hydraulic Filter - Replace after first week of operation then every three (3) months.
4. Cable - Use oil or approved cable lubricant.
5. Cylinder Pivot Bearings - use GP Grease.
6. Underlift and Tower Pivot - Drydene SFG or equivalent.
7. Crossbar Pivot Pin - Drydene SFG or equivalent.
8. Rear Spade Cylinders - GP Grease.
9. Rear Spade Tubes - coat with GP Grease.
10. Slide Pads (Top and Bottom) - GP Grease.
11. Boom End Swivels - GP Grease.
12. Sheaves - GP Grease.
13. Control Handle Shafts - GP Grease.
14. Compartment Door Pivots - Use SAE 30 Oil.

Section V - MAINTENANCE (cont'd)

5.7 FILTER/REGULATOR OPERATION AND SERVICE

- (a) The miniature filter/regulator and miniature lubricator are installed on the aft bulkhead of the left rear Control Station so that air flows in the direction of the arrow on body. See Figure 5.1.

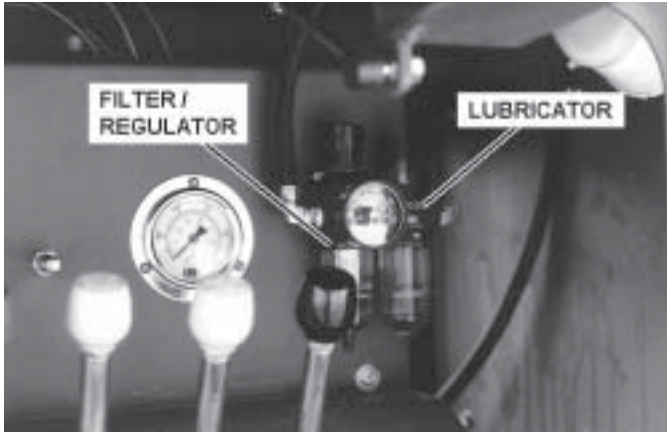

FIGURE 5.1

- (b) The filter/regulator and lubricator are installed upstream from the device(s) they are to protect and lubricate.
- (c) Both free moisture and solids are removed automatically by the filter/regulator.
- (d) Drain whenever water level in sump reaches the lower baffle.
- (e) The filter element should be removed and replaced whenever the pressure differential across the filter is 10 PSIG.
- (f) To remove the filter element: SHUT AIR LINE DOWN and exhaust the primary and secondary pressure.
1. Unscrew threaded bowl.
 2. Unscrew element and remove.
 3. Clean bowl and internal parts before reassembling.
 4. Attach clean element assembly and tighten firmly.

Section V - MAINTENANCE (cont'd)

5.7 FILTER/REGULATOR OPERATION AND SERVICE (Cont'd)

5. Replace bowl gasket; lubricate gasket to assist in retaining it in position. Use only mineral base oils or grease. Do NOT use synthetic oils such as esters, and do NOT use silicones.
 6. Screw bowl into body and tighten firmly.
- (g) The regulator may be serviced without removing it from the line. Before disassembling filter/regulator, SHUT OFF AIR SUPPLY AND EXHAUST PRIMARY AND SECONDARY PRESSURE. Disengage the adjusting knob by pulling upward. Turn the adjusting knob counterclockwise until compression is released from pressure control spring. For servicing diaphragm, unscrew bonnet from body. For servicing poppet, remove threaded bowl and filter element assembly.
 - (h) BEFORE TURNING ON AIR SUPPLY, TURN THE ADJUSTING KNOB COUNTERCLOCKWISE UNTIL COMPRESSION IS RELEASED FROM PRESSURE CONTROL SPRING. Turn on air pressure. Then proceed to adjust the desired downstream pressure by turning adjusting knob clockwise. This permits pressure to build up slowly in the downstream line.
 - (i) To decrease regulated pressure settings, always reset from a pressure lower than the final setting required. For example, lowering the secondary pressure from 80 PSI to 60 PSI is best accomplished by dropping the secondary pressure to 50 PSI, then adjusting upward to 60 PSI.
 - (j) When desired secondary pressure settings have been reached, push the adjusting knob down to lock.

Section V - MAINTENANCE (cont'd)

5.8 LUBRICATOR OPERATION AND SERVICE

- (a) FILLING - Inlet pressure must be eliminated before the fill plug or bowl is removed. Fill to fill line on the bowl (DO NOT OVERFILL) with oil of 100 to 200 SSU viscosity at 100° F and an aniline point greater than 200° F - same as SAE No. 10 (petroleum base hydraulic oils are good examples). DO NOT USE OILS WITH ADHESIVES OR TACKY ADDITIVES. COMPOUNDED OILS CONTAINING SOLVENTS, GRAPHITE, SOAPS OR DETERGENTS (automotive oils generally contain detergent) ARE NOT RECOMMENDED.
- (b) Replace the fill plug and/or bowl assembly firmly - excessive torque is not necessary. The lubricator is now ready for setting. Repressurize the lubricator.
- (c) OIL DELIVERY ADJUSTMENT - To adjust oil delivery, turn adjustment knob on the top of the lubricator.

Leaner - Clockwise

Richer - Counterclockwise

By counting the number of drops per minute in the sight dome, you can adjust to your requirements. 25 drops per minute equal one ounce per hour - volume of oil passing through sight dome.

NOTE: This is a constant density type lubricator which delivers a constant ratio of oil air flow. Therefore, if air flow increases or decreases, oil delivery will be adjusted proportionally. ONLY IF A DIFFERENT RATIO IS DESIRED SHOULD YOUR ADJUSTMENT KNOB SETTING BE CHANGED AFTER YOUR INITIAL SETTING.

- (d) MAXIMUM PRESSURE AND TEMPERATURE - 90 PSIG @ 125° F.
- (e) TO CLEAN POLYCARBONATE BOWLS, USE MILD SOAP AND WATER ONLY! DO NOT use detergents or cleansing agents, such as acetone, alcohol, benzene, carbon tetrachloride, gasoline, toluene, etc., which are damaging to this plastic.

Section VI - PARTS

This Section is provided by the manufacturer for the purpose of ordering any component part of the **CENTURY 4024 Wrecker / Integrated Underlift** that may be required when part replacement is necessary. Be certain to use only original equipment replacement parts for warranty purposes as well as for keeping your **CENTURY 4024 Wrecker / Integrated Underlift** in its original state and optimum operating capacities. When ordering replacement or spare parts be sure to provide the following information to the manufacturer's **Parts Department**.

1. **Manual Number & Date of Publication**
2. **Manual Page Number**
3. **Page Title**
4. **Reference Number of Part Desired**
5. **Part Number**
6. **Part Description**
7. **Quantity of Part Desired**

Providing this information will help ensure that the correct parts will be delivered to you in an expedient manner without delay. Should additional information be required for repair or replacement of certain components, contact your Wrecker Manufacturer Authorized Representative.

The Manufacturer reserves the right, without notice or obligation, to improve or modify their products, which may change the specifications, models and feature availability.

Section VI - PARTS (cont'd) SUBFRAME ASSEMBLY

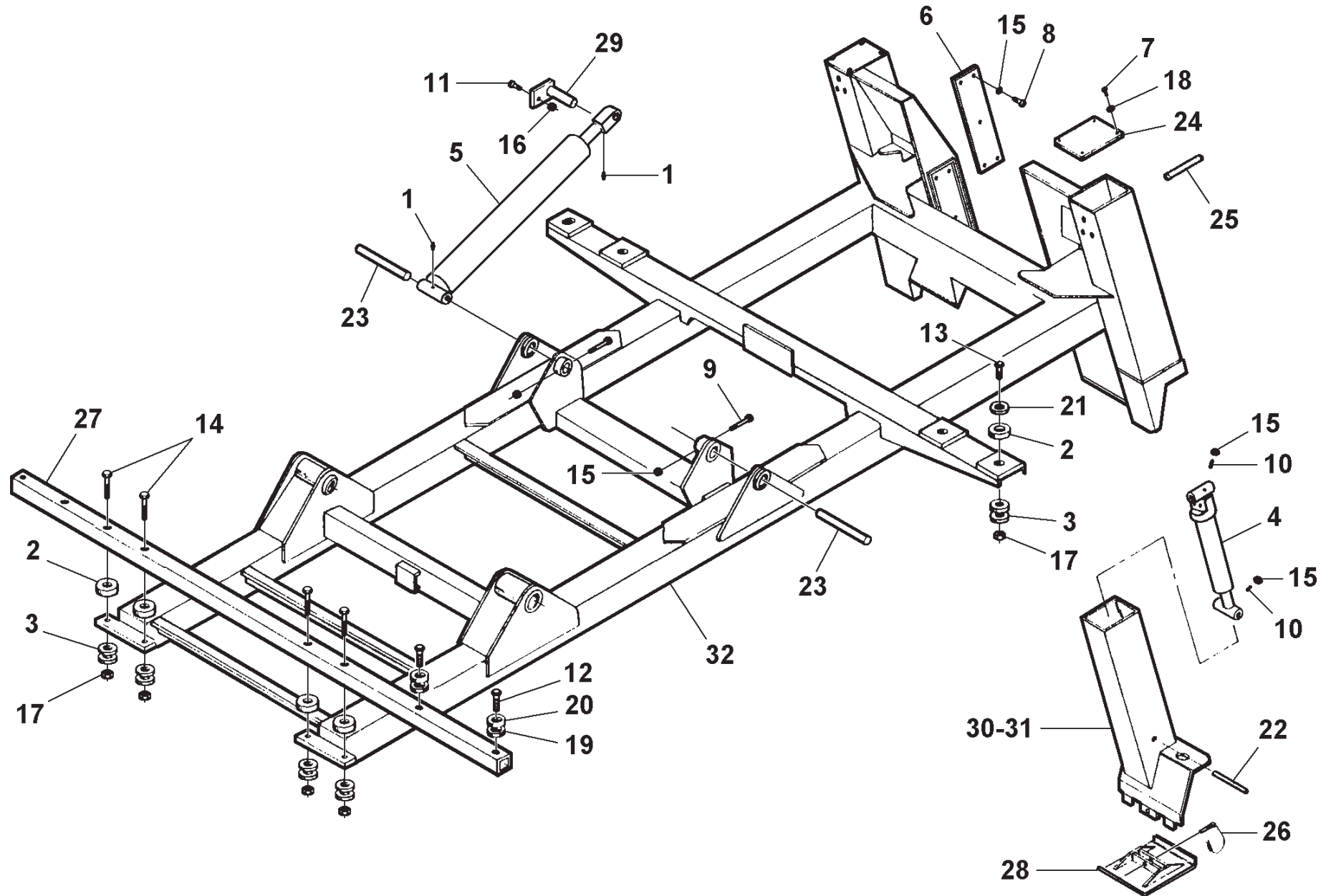

Section VI - PARTS (cont'd)
SUBFRAME ASSEMBLY

Section VI - PARTS (cont'd)
BODY ASSEMBLY

REF. NO.	NO. REQ'D	PART NUMBER	DESCRIPTION
1	6	0300113	GREASE FITTING
2	8	0302540	CENTER BONDED MOUNT
3	12.	0302541	SPECIAL WASHER
4	REF.	0302616	SPADE CYLINDER
5	REF.	0303091	BOOM LIFT CYLINDER
6	2	0303140	RAMP PAD
7	8	0400066	SCREW, 1/4"-20 X 3/4" HEX HD CAP
8	10	0400128	SCREW, 3/8"-16 X 1-1/4" FL HD SKT
9	2	0400130	SCREW, 3/8"-16 X 3-1/2" HEX HD CAP
10	4	0400139	SCREW, 3/8"-16 X 1-1/2" HEX SKT SET
11	2	0400181	SCREW, 1/2"-13 X 1-1/2" HEX HD CAP
12	4	0400276	SCREW, 5/8"-11 X 4-1/2" HEX HD CAP
13	4	0400281	SCREW, 3/4"-10 X 3-1/2" HEX HD CAP
14	4	0400294	SCREW, 3/4"-10 X 6-1/2" HEX HD CAP
15	16	0400392	NUT, 3/8"-16 NYLOK HEX
16	4	0400408	NUT, 1/2"-13 NYLOK HEX
17	4	0400430	NUT, 3/4"-10 NYLOK HEX
18	8	0400452	LOCKWASHER, 1/4" HELICAL
19	8	0400506	WASHER, 5/8" FLAT
20	4	0400508	LOCKWASHER, 5/8" HELICAL
21	8	0400510	WASHER, 3/4" FLAT
22	2	0705500	SHAFT, LOWER SPADE
23	2	0707341	PIN, LIFT CYLINDER
24	2	0707377	COVER, SPADE TUBE
25	2	0707394	SHAFT, UPPER SPADE
26	--	0707199	PIN, SPADE PAD
--	4	0301551	CABLE SLEEVE, 1/16"
--	4	0301553	CABLE ASSEMBLY, 1/16" X 17"
--	2	0302474	PIN, LYNCH
--	4	0400044	DRIVE SCREW, #10 X 1/2" RD HD
--	2	0400563	ROLL PIN, 3/16" X 1-3/4"
--	4	0702604	PROTECTIVE HOSE TUBE, 14"
27	1	0802211	FRONT BODY MTG TUBE
28	2	0802221	SPADE PAD
29	2	0802240	PIVOT PIN, LIFT CYLINDER
30	1	0802243	INNER SPADE, LEFT
31	1	0802244	INNER SPADE, RIGHT
32	1	0802863	4024 SUBFRAME WELDMENT
33	--	0903136	SAFETY CHAIN ASSEMBLY (NOT SHOWN)
--	2	0303086	SAFETY CHAIN
--	2	0400211	SCREW, 1/2"-13 X 1-34" HEX HD CAP
--	2	0400408	NUT, 1/2"-13 NYLOK HEX
--	2	0400492	WASHER, 1/2" FLAT

Section VI - PARTS (cont'd)
BODY ASSEMBLY

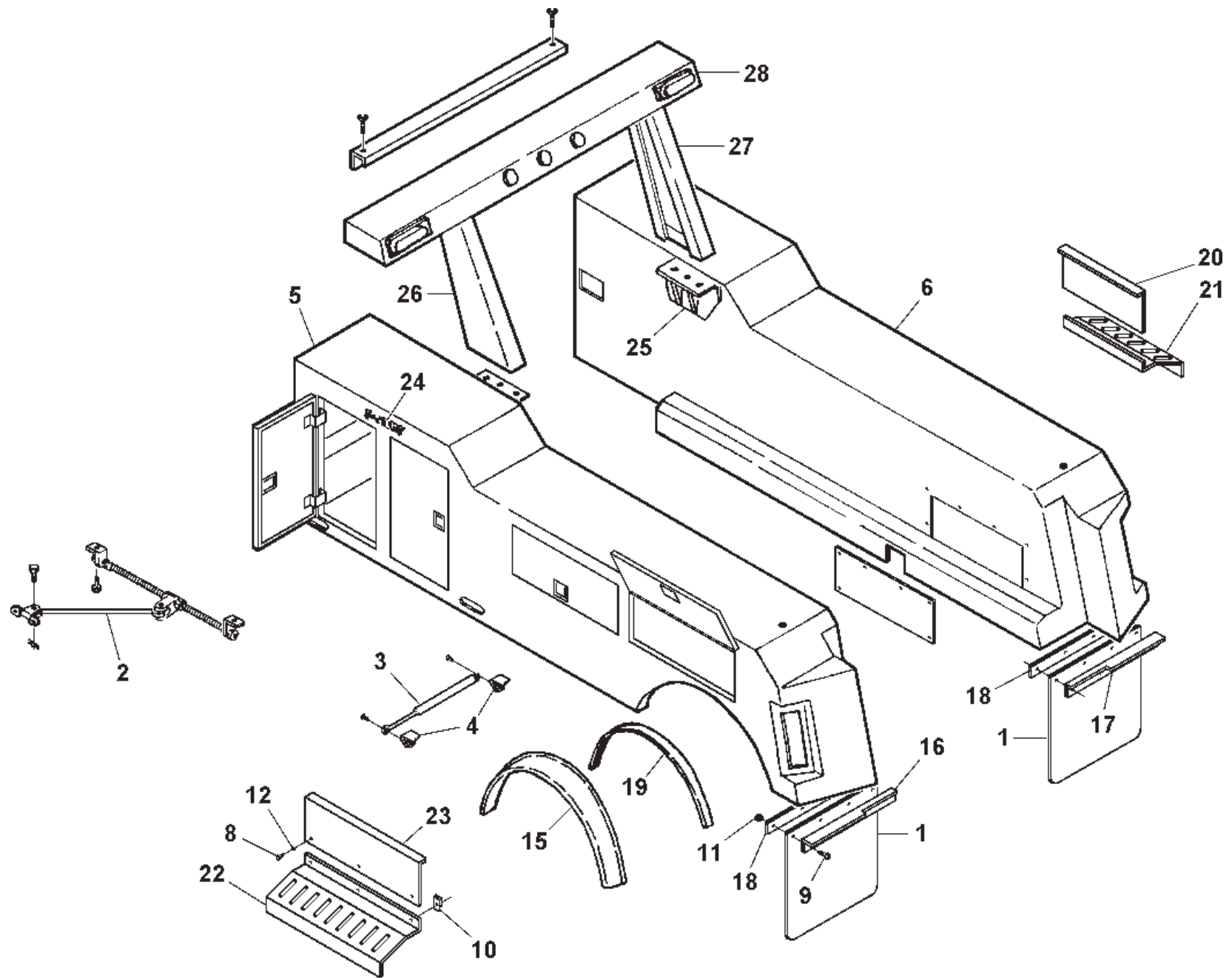

Section VI - PARTS (cont'd)

BODY ASSEMBLY

REF. NO.	NO. REQ'D	PART NUMBER	DESCRIPTION
1	2	0301223	MUD FLAP
2	4	0301912	DOOR CHECK, 11"
3	4	0902571	GAS SPRING CYLINDER
4	8	0302572	"L" BRACKET
5	1	0302612	BODY SIDE, 120" C.A., LEFT
6	1	0302613	BODY SIDE, 120" C.A., RIGHT
7	1	0303061	BACKUP ALARM
8	8	0400066	SCREW, 1/4"-20 X 3/4" HEX HD CAP
9	8	0400122	SCREW, 3/8"-16 X 1-1/4" HEX HD CAP
10	6	0400369	CLIP, 1/4" TINNERMAN
11	8	0400392	NUT, 3/8"-16 NYLOK HEX
12	6	0400451	WASHER, 1/4" FLAT
13	8	0400452	LOCKWASHER, 1/4" HELICAL
14	40	0400566	RIVET, 1/4"
15	2	0704047	RUBBER FENDER
16	1	0705090	MUDFLAP MTG ANGLE, LEFT
17	1	0705091	MUDFLAP MTG ANGLE, RIGHT
18	2	0705092	BAR, MUDFLAP
19	2	0706609	RETAINING STRIP, RUBBER FENDER
20	1	0711289	PANEL, SWITCH
21	1	0711290	PANEL, CONTROL
22	1	0711292	PANEL, CONTROL
23	1	0711344	PANEL, GAUGE

REF. NO.	NO. REQ'D	PART NUMBER	DESCRIPTION
24	1	0901496	CENTURY NAMEPLATE KIT
--	--	0902328	BODY MOUNTING KIT
--	28	0400288	SCREW, 3/4"-10 X 2-1/2" HEX HD CAP
--	28	0400431	NUT, 3/4"-10 NYLOK HEX
--	2	0707174	ANGLE, TAILGATE MOUNTING
--	2	0711256	MOUNTING PLATE
--	--	124001727	LIGHT BAR, STANDARD
--	2	0301706	GASKET, LIGHT BAR
--	4	0400126	SCREW, 3/8"-16 X 1" HEX HD CAP
--	12	0400177	SCREW, 1/2"-13 X 1-1/4" HEX HD CAP
--	6	0400181	SCREW, 1/2"-13 X 1-1/2" HEX HD CAP
--	4	0400392	NUT, 3/8"-16 NYLOK HEX
--	18	0400408	NUT, 1/2"-13 NYLOCK HEX
--	12	0400492	WASHER, 1/2" FLAT
25	2	0802254	MOUNTING ANGLE
26	1	0802256	SUPPORT CHANNEL, LEFT
27	1	0802257	SUPPORT CHANNEL, RIGHT
28	1	0802260	TOP CHANNEL

Section VI - PARTS (cont'd) BOOM ASSEMBLY

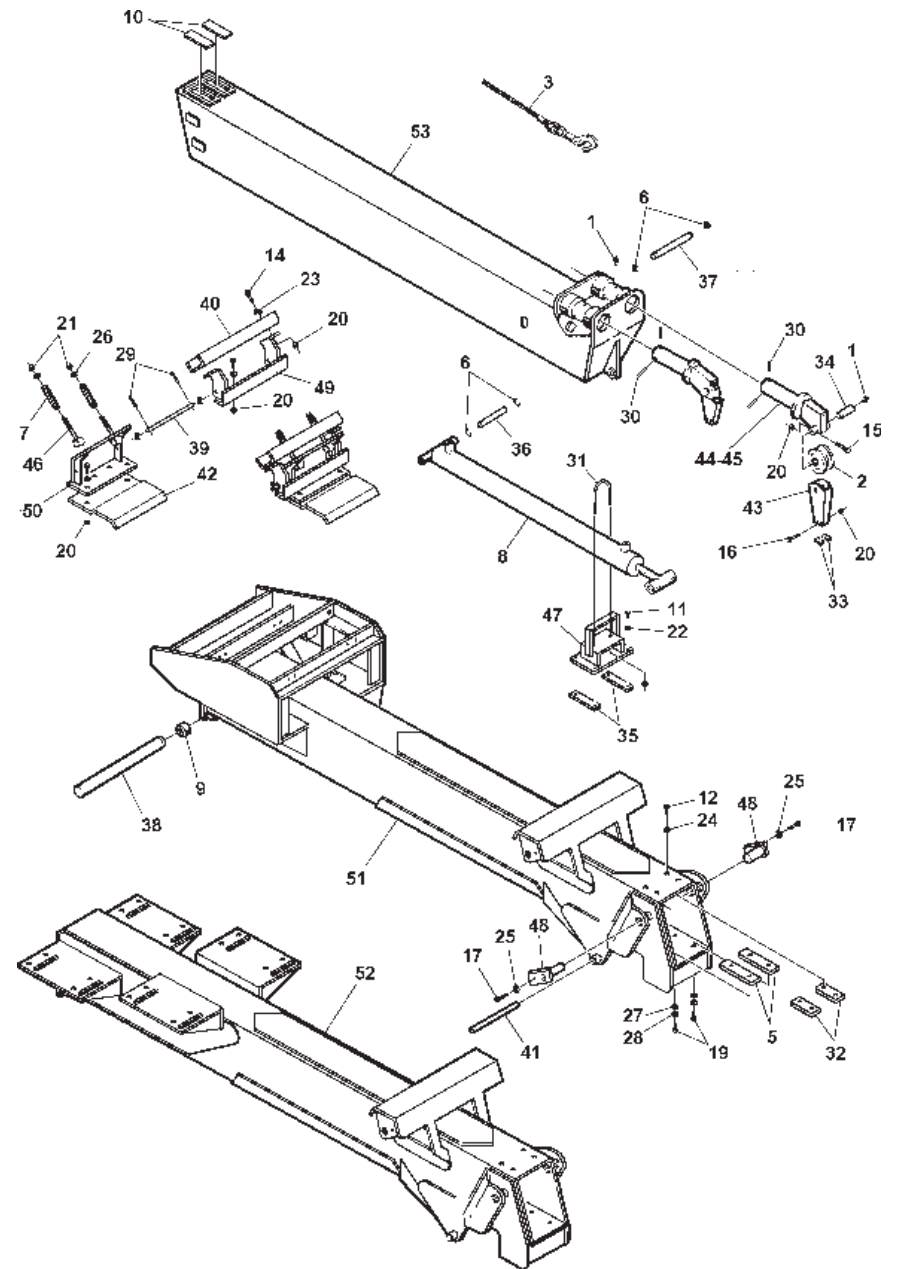

Section VI - PARTS (cont'd)

BOOM ASSEMBLY

REF. NO.	NO. REQ'D	PART NUMBER	DESCRIPTION
1	6	0300113	GREASE FITTING
2	2	0300626	SHEAVE, 8"
3	2	0303050	WIRE ROPE, 6 X 19 IPS, 9/16" X 175' 0
4	2	0301895	GREASE FITTING, STR 1/8"
5	2	0301923	SLIDE PAD, BOOM BOTTOM
6	4	0301959	SNAP RING, 1-1/2" INTERNAL
7	4	0302378	COMPRESSION SPRING
8	REF.	0302614	EXTEND CYLINDER
9	2	0302619	BUSHING, 2-1/4" OD X 2" ID X 1-1/2"
10	2	0302628	SLIDE PAD, INNER BOOM
11	4	0400066	SCREW, 1/4"-20 X 3/4" HEX HD CAP
12	4	0400121	SCREW, 3/8"-16 X 3/4" HEX HD CAP
13	4	0400122	SCREW, 3/8"-16 X 1-1/4" HEX HD CAP
14	18	0400132	SCREW, 3/8"-16 X 1-1/2" HEX HD CAP
15	2	0400133	SCREW, 3/8"-16 X 3" HEX HD CAP
16	4	0400150	SCREW, 3/8"-16 X 2-1/2" HEX HD CAP
17	2	0400176	SCREW, 1/2"-13 X 1" HEX HD CAP
18	1	0400220	SCREW, 1/2"-13 X 5-1/2" HEX HD CAP
19	4	0400248	SCREW, 5/8"-11 X 1" HEX HD CAP
20	24	0400392	NUT, 3/8"-16 NYLOK HEX
21	4	0400408	NUT, 1/2"-13 NYLOK HEX
22	4	0400451	WASHER, 1/4" FLAT
23	16	0400480	WASHER, 3/8" FLAT
24	4	0400482	LOCKWASHER, 3/8" HELICAL
25	2	0400491	LOCKWASHER, 1/2" HELICAL
26	8	0400492	WASHER, 1/2" FLAT
27	4	0400506	WASHER, 5/8" FLAT
28	4	0400508	LOCKWASHER, 5/8" HELICAL

REF. NO.	NO. REQ'D	PART NUMBER	DESCRIPTION
29	4	0400543	COTTER PIN, 1/8" X 3/4"
30	6	0400554	ROLL PIN, 3/8" X 1"
	31	1	0400581 PIPE U-BOLT, 3/8"-18 X 3"
32	2	0700778	TOP SPACER, OUTER BOOM
33	4	0700801	CABLE GUIDE, BOTTOM
34	2	0700888	SHAFT, SHEAVE
35	2	0703442	SKID, FAIRLEAD ASSEMBLY
36	1	0707343	EXTEND CYLINDER PIN, BASE
37	1	0707344	EXTEND CYLINDER PIN, ROD
38	1	0707342	PIVOT PIN, BOOM
39	2	0709361	PIVOT ROD
40	2	0709362	SPRING CHANNEL
41	1	0710143	PIN, TILT CYLINDER BASE END
42	1	0708645	PLATE, FLAPPER (4024T)
--	2	0711390	PLATE, FLAPPER (4024T3)
43	2	0800286	CABLE GUIDE
44	1	0800509	SWIVEL WELDMENT, LEFT
45	1	0800510	SWIVEL WELDMENT, RIGHT
46	4	0802218	SPRING PIN
47	1	0802246	CYLINDER SUPPORT
48	2	0802935	PIN, TOWER PIVOT
49	2	0802775	TENSIONER, MOUNTING BRACKET
50	2	0802774	TENSIONER, BRACKET
51	1	0802864	OUTER BOOM WELDMENT (4024T)
52	1	0803219	OUTER BOOM WELDMENT (4024T2)
53	1	0802931	OUTER BOOM WELDMENT (4024T)
--	1	0803220	OUTER BOOM WELDMENT (4024T2)

Section VI - PARTS (cont'd) UNDERLIFT & TOWER ASSEMBLY

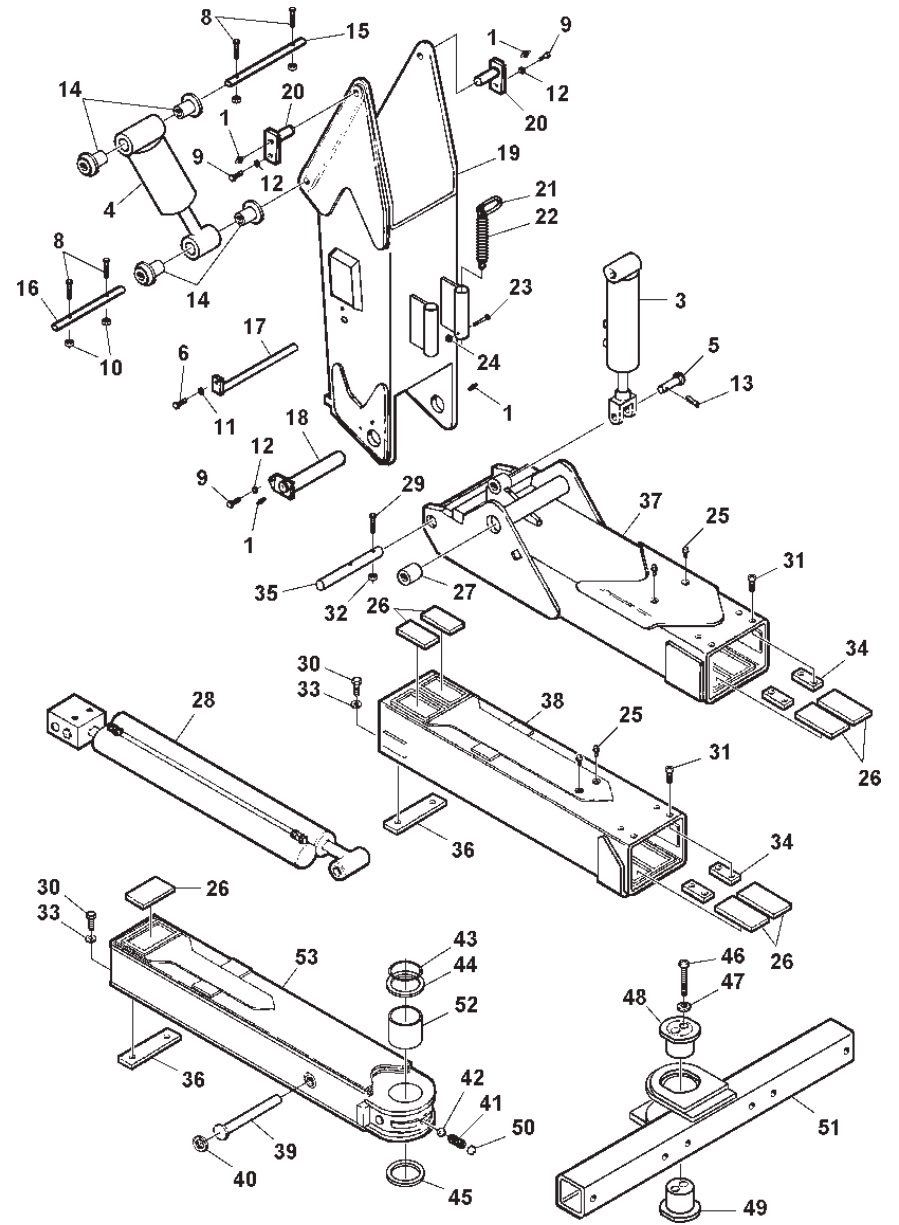

Section VI - PARTS (cont'd)

UNDERLIFT & TOWER ASSEMBLY

REF. NO.	NO. REQ'D	PART NUMBER	DESCRIPTION
1	2	0300113	GREASE FITTING
2	REF.	0301895	GREASE FITTING, 1/8" STR
3	REF.	0301765	FOLD CYLINDER
4	1	0302791	TILT CYLINDER
5	1	0304246	PIN, FOLD CYLINDER CLEVIS
6	1	0400121	SCREW, 3/8"-16 X 3/4" HEX HD CAP
7	1	0400122	SCREW, 3/8"-16 X 1-1/4" HEX HD CAP
8	4	0400167	SCREW, 3/8"-16 X 3-3/4" HEX HD CAP
9	4	0400176	SCREW, 1/2"-13 X 1" HEX HD CAP
10	3	0400392	NUT, 3/8"-16 NYLOK HEX
11	7	0400482	LOCKWASHER, 3/8" HELICAL
12	1	0400491	LOCKWASHER, 1/2" HELICAL
13	3	0400548	COTTER PIN, 3/8" X 2"
14	4	0710140	BUSHING, TILT CYLINDER
15	1	0710143	PIN, TILT CYLINDER BASE END
16	4	0710144	PIN, TILT CYLINDER ROD END
17	1	0802220	PIN WELDMENT, FOLD CYLINDER
18	1	0802237	PIVOT PIN, UNDERLIFT
19	1	0802865	TOWER WELDMENT 4024
20	1	0802935	WELDMENT, TOWER PIVOT PIN
--	--	0901716	STOW KIT, WINCH CABLE
21	2	0301691	MASTER LINK, OBLONG
22	2	0302273	SPRING, WINCH CABLE TIE-BACK
23	2	0400205	SCREW, 1/2"-13 X 3" HEX HD CAP
24	2	0400408	NUT, 1/2"-13 NYLOK HEX
--	--	0903059	HORIZONTAL BOOM ASSEMBLY
25	6	0300113	GREASE FITTING, 1/8" STR
26	7	0302561	SLIDE PAD
27	2	0302619	SPRING BUSHING

REF. NO.	NO. REQ'D	PART NUMBER	DESCRIPTION
--	--	0903752	HORIZONTAL BOOM ASSEMBLY (con't)
28	4	0303331	EXTEND CYLINDER
29	8	0400107	SCREW, 5/16"-18 X 2-1/2" HEX HD CAP
30	8	0400151	SCREW, 3/8"-24 X 5/8" BUTTON HD SKT
31	5	0400228	SCREW, 3/8"-24 X 5/8" HEX HD CAP
32	2	0400382	NUT, 5/16"-18 NYLOK HEX
33	9	0400481	LOCKWASHER, 3/8" EXTERNAL TOOTH
34	5	0707034	STOP PLATE
35	1	0707271	EXTEND CYLINDER PIN, BASE END
36	1	0707452	SPACER PAD
37	1	0803231	OUTER BOOM WELDMENT
38	2	0803232	2ND STAGE BOOM WELDMENT
39	1	HD86	EXTEND CYLINDER PIN WELDMENT
40	1	HD89	RETAINING RING
--	--	0903175	CROSSBAR ASSEMBLY
41	1	0301197	COMPRESSION SPRING, CROSS BAR
42	1	0301398	DETENT BALL, 1-3/16"
43	1	0303087	"O" RING, PIVOT PIN
44	2	0303105	THRUST WASHER, 1/8"
45	2	0303106	THRUST WASHER, 1/16"
46	2	0400354	SCREW, 5/8"-11 X 4-1/2" SKT HD CAP
47	2	0400508	LOCKWASHER, 5/8" HELICAL
48	1	0710054	PIVOT PIN, TOP HALF
49	1	0710055	PIVOT PIN, BOTTOM HALF
50	1	0710195	SPACER, DETENT SPRING
51	1	0802919	CROSSBAR WELDMENT
--	--	0903751	INNER BOOM ASSEMBLY
52	1	0302625	BUSHING, PIVOT PIN
53	8	0803320	3RD STAGE BOOM WELDMENT

Section VI - PARTS (cont'd) UNDERLIFT HYDRAULICS

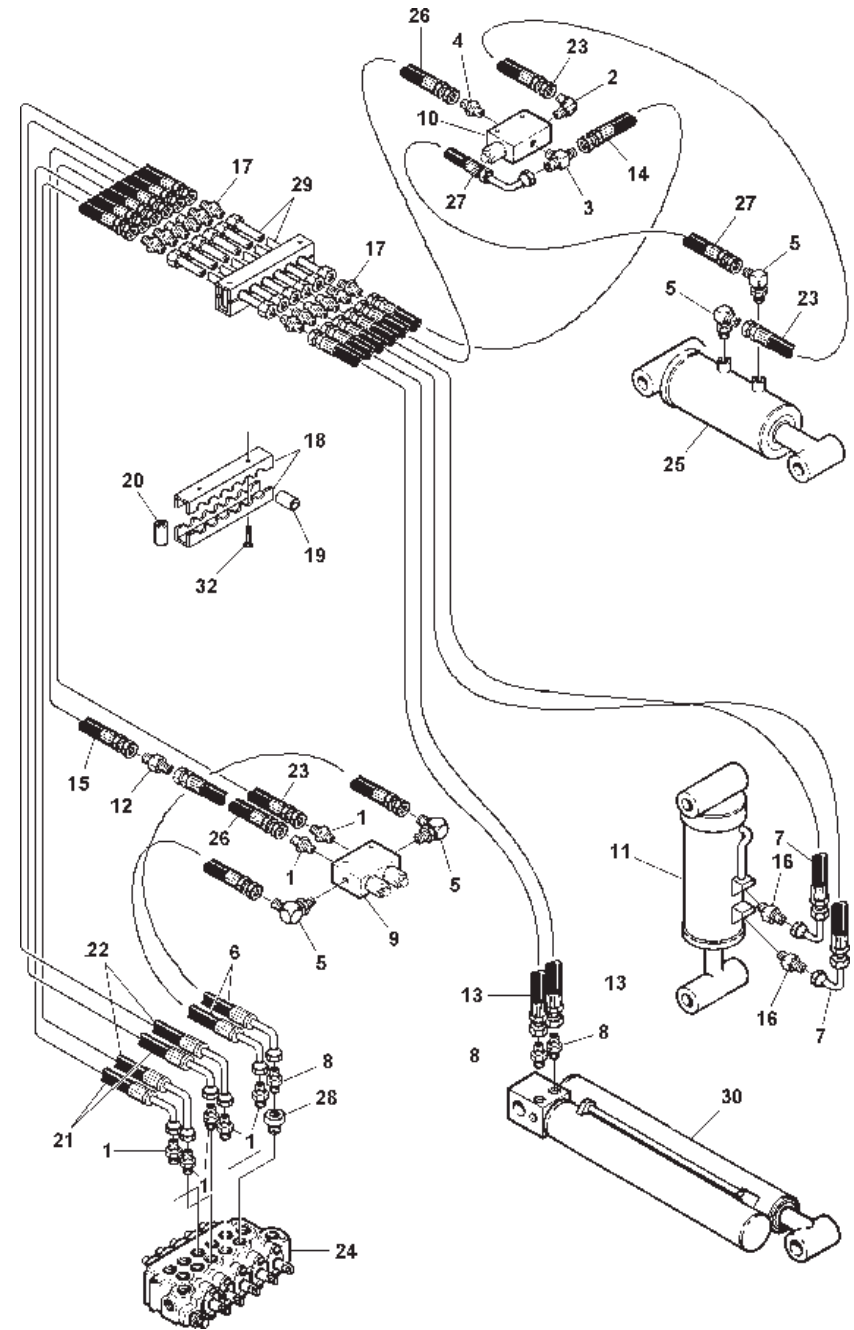

Section VI - PARTS (cont'd)

UNDERLIFT HYDRAULICS

REF. NO.	NO. REQ'D	PART NUMBER	DESCRIPTION
1	7	0300044	CONNECTOR, 6MJ-8MB
2	1	0300142	ELBOW, 6MJ-4MP90
3	1	0300206	BRANCH TEE, 6MJ-6MJ-4MP
4	1	0301424	CONNECTOR, 6MJ-4MP
5	4	0301470	ELBOW, 6MJ-8MP90
6	2	0301473	HOSE ASSEMBLY, 18"
7	2	0301485	HOSE ASSEMBLY, 81"
8	3	0301522	CONNECTOR, 6MJ-6MB
9	1	0301730	DOUBLE HOLDING VALVE
10	1	0301731	HOLDING VALVE
11	1	0301765	FOLD CYLINDER
12	1	0301837	IN-LINE ORIFICE
13	2	0301880	HOSE ASSEMBLY, 107"
14	1	0302035	HOSE ASSEMBLY, 18"
15	1	0302036	HOSE ASSEMBLY, 26"
16	2	0302509	ELBOW, 6MJ-8MP90
17	12	0302514	ADAPTER, 8MJ-6MJ
18	4	0302548	CLAMPING UNIT
19	12	0302549	SPLIT BUSHING, 1/2"
20	4	0302551	STACKING NUT, SKT HD
21	2	0302581	HOSE ASSEMBLY, 36"
22	2	0302582	HOSE ASSEMBLY, 36"
23	2	0302596	HOSE ASSEMBLY, 34"
24	REF.	REF.	CONTROL VALVE
25	1	0302791	TILT CYLINDER
26	2	0302805	HOSE ASSEMBLY, 10"
27	1	0302815	HOSE ASSEMBLY, 32"
28	1	0303017	CONNECTOR, 8MB-6FB
29	6	0303108	TUBE ASSEMBLY
30	1	0303331	EXTEND CYLINDER
31	2	0400064	SCREW, 1/4"-20 X 2" HEX HD CAP SLOTTED
32	4	0400118	SCREW, 5/16-18 X 3/4 HEX HD CAP
33	2	0400366	NUT, 1/4"-20 HEX
34	2	0400451	WASHER, 1/4" FLAT
35	2	0400452	LOCKWASHER, 1/4" HELICAL

Section VI - PARTS (cont'd)

BOOM ELEVATION HYDRAULICS

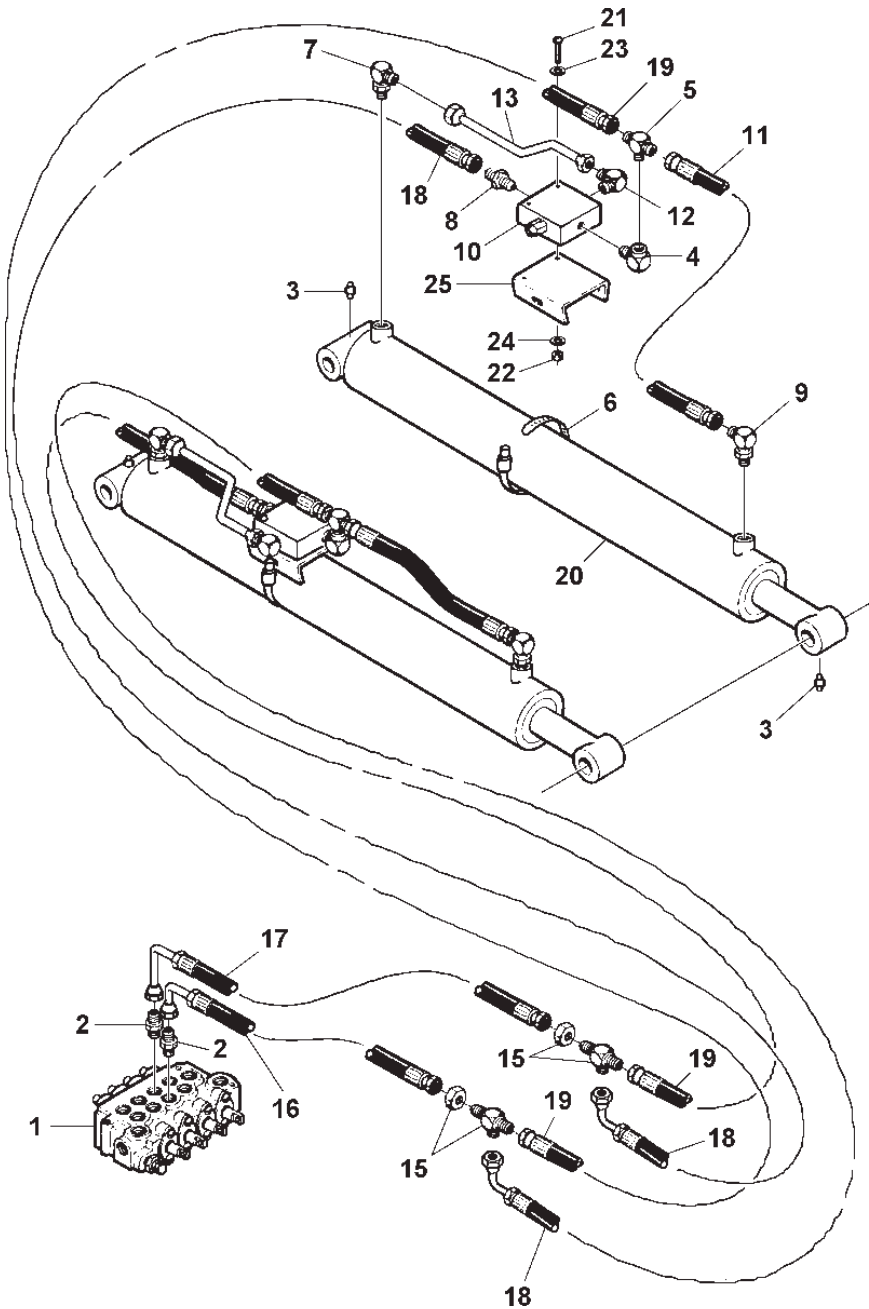

Section VI - PARTS (cont'd)

BOOM ELEVATION HYDRAULICS

REF. NO.	NO. REQ'D	PART NUMBER	DESCRIPTION
1	REF.	REF	CONTROL VALVE
2	2	0300044	CONNECTOR, 6MJ-8MB
3	4	0300113	GREASE FITTING
4	2	0300147	ELBOW, STREET 4MP-4FP90
5	2	0300206	BRANCH TEE, 6MJ-6MJ-4MP
6	2	0300710	CLAMP, CHECK VALVE RETAINING, 6-1/2"
9	4	0301388	ELBOW, 8MJ-8MB90
8	2	0301425	CONNECTOR, 6MJ-6MB
9	4	0301470	ELBOW, 6MJ-8MB90
10	2	0301731	HOLDING VALVE
16	1	0302035	HOSE ASSEMBLY, 18"
11	2	0302051	ELBOW 8MJ-6MP90
12	2	0302568	TUBING, HYDRAULIC
13	4	0302569	WIRE TIE, 29-3/4"
14	2	0302575	BULKHEAD RUN TEE W/NUT
15	2	0302581	HOSE ASSEMBLY, 36"
16	1	0302582	HOSE ASSEMBLY, 36"
17	1	0302604	HOSE ASSEMBLY, 44"
18	2	0302632	HOSE ASSEMBLY, 40"
16	1	0303091	CYLINDER BOOM LIFT
20	4	0400064	SCREW, 1/4"-20 X 2-1/4" RD HD SLOTTED
21	4	0400366	NUT, 1/4"-20 HEX
22	4	0400451	WASHER, 1/4" FLAT
23	4	0400452	LOCKWASHER, 1/4" HELICAL
24	2	0703001	BRACKET, CHECK VALVE MOUNTING

Section VI - PARTS (cont'd)

BOOM EXTENSION HYDRAULICS

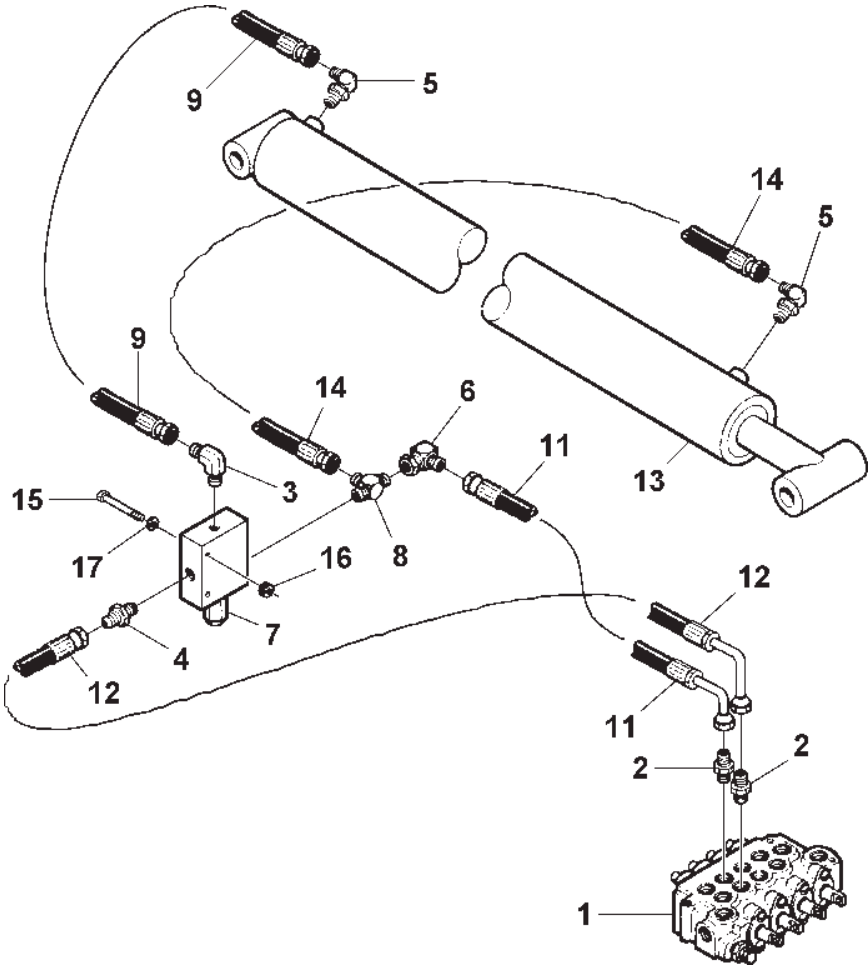

Section VI - PARTS (cont'd)
BOOM EXTENSION HYDRAULICS

REF. NO.	NO. REQ'D	PART NUMBER	DESCRIPTION
1	REF.	REF	CONTROL VALVE
2	2	0300044	CONNECTOR, 6MJ-8MB
3	1	0300209	ELBOW, 6MJ-6MP90
4	1	0301425	CONNECTOR, 6MJ-6MB
5	2	0301620	ELBOW, 6MJ-6MB90
6	1	0301696	ELBOW, 6MJ-6FJX90
7	1	0301731	HOLDING VALVE
8	1	0301782	MALE RUN TEE, 6MJ-4MP-6MJ
9	1	0302000	HOSE ASSEMBLY, 24"
10	5	0302062	WIRE TIE, 21" (NOT SHOWN)
11	1	0302581	HOSE ASSEMBLY, 36"
12	1	0302605	HOSE ASSEMBLY, 44"
13	1	0302614	EXTEND CYLINDER
14	1	0302635	HOSE ASSEMBLY, 131"
15	2	0400122	SCREW, 3/8"-16 X 1-1/4" HAX HD CAP
16	2	0400392	NUT, 3/8"-16 NYLOCK HEX
17	2	0400480	WASHER, 3/8" FLAT

Section VI - PARTS (cont'd)
PUMP, VALVE & FILTER HYDRAULICS

Section VI - PARTS (cont'd)

PUMP, VALVE & FILTER HYDRAULICS

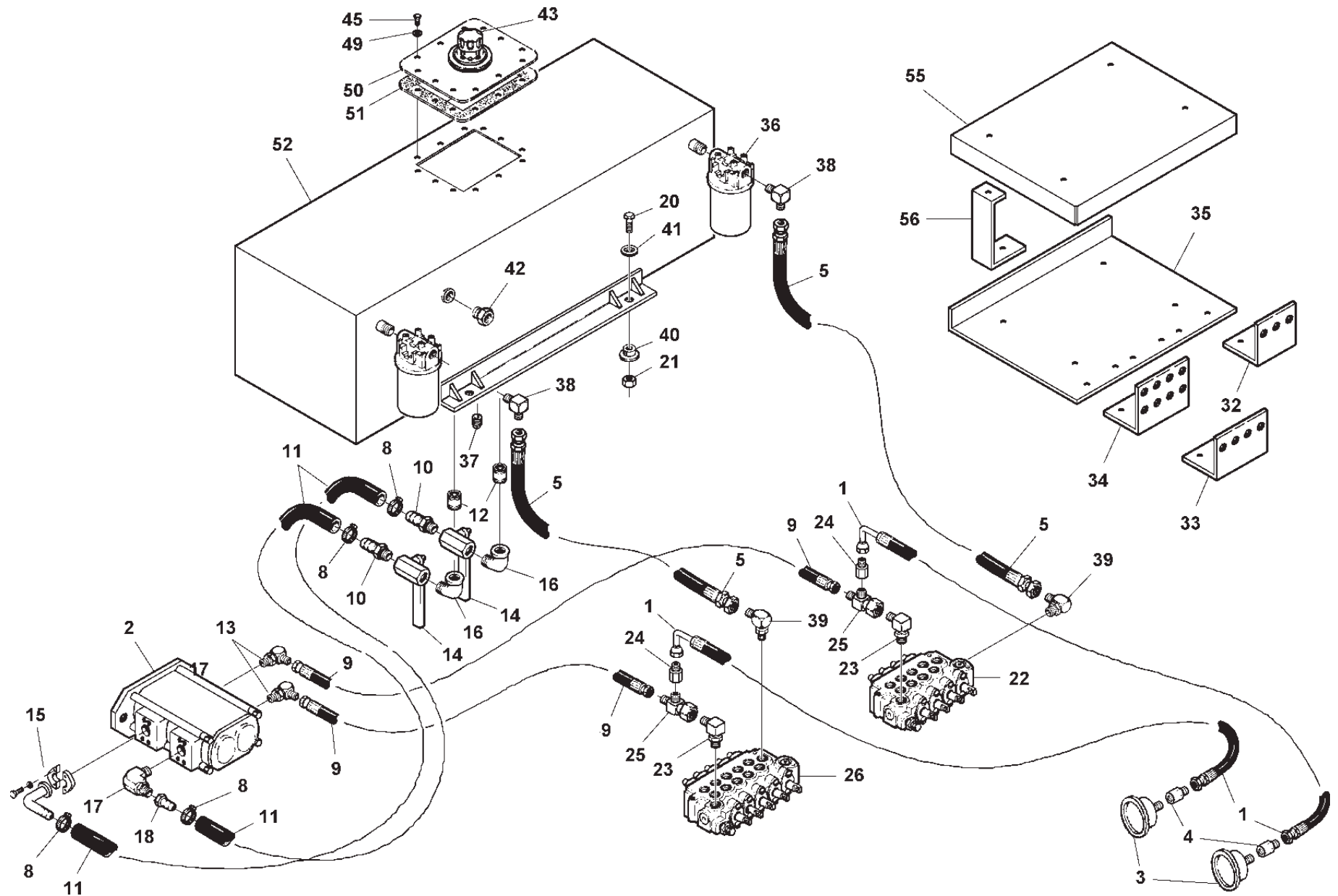

Section VI - PARTS (cont'd)

PUMP, VALVE & FILTER HYDRAULICS

REF. NO.	NO. REQ'D	PART NUMBER	DESCRIPTION
1	2	0301485	HOSE ASSEMBLY, 81"
2	1	0301507	PUMP, OPPOSITE ENGINE
3	2	0302205	GAUGE, FLUSH MOUNT 6000 PSI
4	2	0302577	CONNECTOR, 6MJ-4FP
5	2	0303435	HOSE ASSEMBLY 58"
6	6	0400021	SCREW, #8-32 X 1/2" RD HD PHIL MACH
7	6	0400351	HEX NUT, & STAR WASHER, #8-32
--	--	0903307	PUMP KIT
8	2	0300364	CLAMP HOSE, 1" - 2-1/4"
9	2	0300660	HOSE ASSEMBLY, 120"
10	2	0300666	BARB, 24C4-24MP
11	20 FT.	0300671	SUCTION HOSE, 1-1/2"
12	2	0300891	PIPE NIPPLE, 1-1/2" X 3"
13	2	0301547	ELBOW, 8MJ-12MB90
14	2	0302088	BALL VALVE, BRONZE
15	1	0302242	FLANGE FITTING, 24FL-24 HOSE 90
16	2	0302983	STREET ELBOW, 45° 1-1/2"
17	1	0303032	ELBOW, 24MJ-20MB90
18	1	0303033	HOSE BARB, 24C4-24FJX
19	6	0303290	CLAMP, 2-1/2" INSULATED
20	2	0400188	SCREW, 1/2"-13 X 2 HEX HD CAP
21	2	0400408	NUT, 1/2"-13 NYLOK HEX
--	--	0903535	VALVE PAN ASSEMBLY
22	REF.	REF.	CONTROL VALVE
23	2	0300052	ELBOW, 8MJ-10MB90
24	2	0301995	STRAIGHT ADAPTER, 8FJ-6MJ
25	2	0302052	RUN TEE, 8MJ-8FJX-8MJ
26	REF.	REF.	CONTROL VALVE
27	6	0400135	SCREW, 3/8"-16 X 4-1/2" HEX HD CAP
28	4	0400157	SCREW, 3/8"-16 X 1-3/4" HEX HD CAP

REF. NO.	NO. REQ'D	PART NUMBER	DESCRIPTION
29	10	0400392	NUT, 3/8"-16 NYLOK HEX
30	4	0400480	WASHER, 3/8" FLAT
31	6	0704045	SPACER, CONTROL VALVE
32	2	0711249	PLATE, CONTROL BULKHEAD (L.&R.S.C.)
33	1	0711250	PLATE, CONTROL BULKHEAD (L.&R.S.C.)
34	2	0711251	PLATE, CONTROL BULKHEAD (L.&R.S.C.)
35	1	0711561	PLATE VALVE MOUNTING
--	--	0902353	TANK KIT
36	2	0300136	RETURN LINE FILTER ASSEMBLY
37	1	0300446	PIPE PLUG, 3/4" NPT MALE
38	2	0300615	ELL, 12MJ-12MP90
39	2	0301545	ELBOW, 12MJ-12MP90
40	4	0302227	CENTER BONDED MOUNT
41	4	0302228	SPECIAL WASHER
42	1	0302570	SIGHT GAUGE
43	1	0305006	FILLER CAP
44	6	0400036	SCREW, #10-32 X 1" RD HD MACH
45	12	0400122	SCREW, 3/8"-16 X 1-1/4" HEX HD CAP
46	4	0400146	SCREW, 3/8"-16 X 2-1/4" HEX HD CAP
47	6	0400357	NUT, #10-32 NYLOK HEX
48	4	0400392	NUT, 3/8"-16 NYLOK HEX
49	12	0400482	LOCKWASHER, 3/8"HELICAL
50	1	0705910	COVER PLATE
51	1	0706114	GASKET, CLEAN OUT & FILLER COVER
52	1	0803163	RESERVOIR WELDMENT
--	--	0903696	COVER KIT
53	4	0400121	SCREW, 3/8"-16 X 3/4" HEX HD CAP
54	4	0400392	NUT, 3/8"-16 NYLOK HEX
55	1	0711322	COVER, VALVE
56	4	0711575	SUPPORT, COVER

Section VI - PARTS (cont'd)
WORM DRIVE WINCH
HYDRAULICS & AIR FREE SPOOL

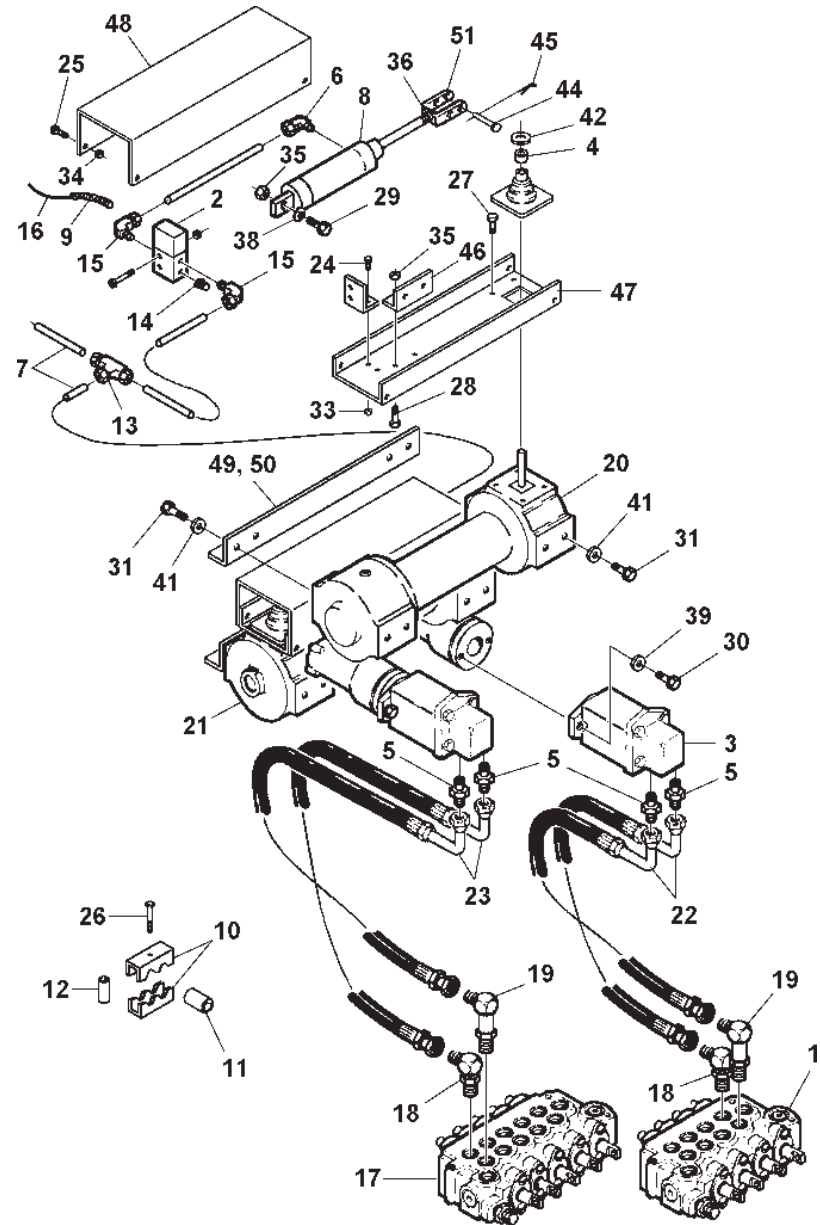

Section VI - PARTS (cont'd)
WORM DRIVE WINCH
HYDRAULICS & AIR FREE SPOOL

REF. NO.	NO. REQ'D	PART NUMBER	DESCRIPTION
1	REF.	0300011	CONTROL VALVE
2	2	0300324	SOLENOID VALVE, AIR CONTROL
3	2	0300691	HYDRAULIC MOTOR
4	2	0300897	RUBBER GROMMET
5	4	0301376	CONNECTOR, 8MJ-10MB
6	2	0301574	ELBOW, 4TB-4MP90
7	18 FT.	0301577	AIR HOSE, 1/4" O.D.
8	2	0302055	AIR CYLINDER
9	7 FT.	0302431	CONVOLUTED LOOM, 3/8"
10	4	0302546	CLAMPING UNIT
11	4	0302550	SPLIT BUSHING, 3/4"
12	2	0302551	STACKING NUT, SKT HD
13	1	0302607	TEE UNION, 4TB-4TB-4TB
14	2	0302677	BREATHER VENT, 1/8" MP
15	4	0302678	ELBOW, 4TB-2MP90
16	1	0302744	AIR FREE SPOOL HARNESS
17	REF.	0302782	CONTROL VALVE
18	2	0302827	CONNECTOR, 10MJ-10MB
19	2	0302828	CONNECTOR, 10MJ-10MBL
20	1	0303049	WINCH, H-700, RIGHT
21	1	0303048	WINCH, H-700 LEFT
22	2	0303131	HOSE ASSEMBLY, 80"
23	2	0303391	HOSE ASSEMBLY, 96"
24	4	0400034	SCREW, #10-32 X 1/2" RD HD PHIL
25	8	0400059	SCREW, 1/4"-20 X 5/8" HEX HD
26	2	0400118	SCREW, 5/16"-18 X 3/4" HEX HD CAP

REF. NO.	NO. REQ'D	PART NUMBER	DESCRIPTION
27	2	0400121	SCREW, 3/8"-16 X 3/4" HEX HD CAP
28	4	0400122	SCREW, 3/8"-16 X 1-1/4" HEX HD CAP
29	2	0400132	SCREW, 3/8"-16 X 1-1/2" HEX HD CAP
30	4	0400238	SCREW, 1/2"-13 X 1-1/2" HEX HD CAP
31	16	0400252	SCREW, 5/8"-11 X 1-1/2" HEX HD CAP
32	8	0400260	SCREW, 5/8"-11 X 2" HEX HD CAP
33	4	0400356	NUT, #10-32 HEX
34	8	0400367	NUT, 1/4"-20 HEX NYLOK
35	8	0400392	NUT, 3/8"-16 HEX NYLOK
36	2	0400412	NUT, 1/2"-20 HEX JAM
37	8	0400421	NUT, 5/8"-11 HEX NYLOK
38	8	0400480	WASHER, 3/8" FLAT
39	8	0400491	LOCKWASHER, 1/2" HELICAL
40	16	0400504	WASHER, 5/8" SAE
41	16	0400508	LOCKWASHER, 5/8" HELICAL
42	2	0400510	WASHER, 3/4" FLAT
43	4	0400520	LOCKWASHER, #10 HELICAL
44	2	0400530	CLEVIS PIN, 5/16" X 1-1/4"
45	2	0400543	COTTER PIN, 1/8" X 3/4"
46	2	0702382	MOUNTING ANGLE
47	2	0706859	CHANNEL, CYLINDER MOUNTING
48	2	0706860	CHANNEL, CYLINDER COVER
49	1	0709313	WINCH MOUNTING ANGLE, FRONT
50	1	0709314	WINCH MOUNTING ANGLE, REAR
51	2	0800772	ADJUSTMENT YOKE

Section VI - PARTS (cont'd)
PLANETARY WINCH
HYDRAULICS & AIR FREE SPOOL

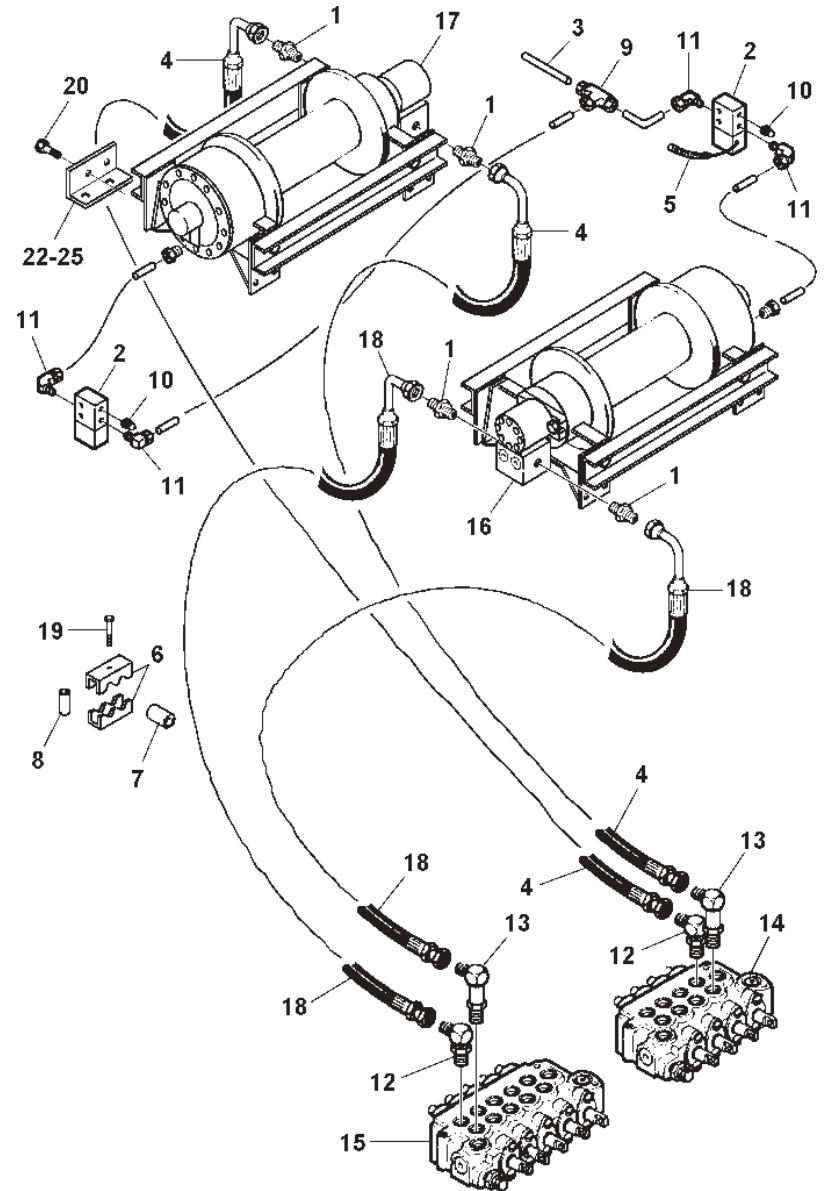

Section VI - PARTS (cont'd)

PLANETARY WINCH

HYDRAULICS & AIR FREE SPOOL

REF. NO.	NO. REQ'D	PART NUMBER	DESCRIPTION
1	4	0300041	CONNECTOR, 8MJ-8MB
2	2	0300324	SOLENOID VALVE, AIR CONTROL
3	18 FT.	0301577	AIR HOSE, 1/4" O.D.
4	2	0301207	HOSE ASSEMBLY, 72"
5	7 FT.	0302431	CONVOLUTED LOOM, 3/8"
6	4	0302546	CLAMPING UNIT
7	4	0302550	SPLIT BUSHING, 3/4"
8	2	0302551	STACKING NUT, SKT HD
9	1	0302607	TEE UNION, 4TB-4TB-4TB
10	2	0302677	BREATHER VENT, 1/8" MP
11	4	0302678	ELBOW, 4TB-2MP90
12	2	0302827	CONNECTOR, 10MJ-10MB
13	2	0302828	CONNECTOR, 10MJ-10MBL
14	1	0303093	CONTROL VALVE
15	1	0303094	CONTROL VALVE
16	1	0303374	WINCH, LEFT
17	1	0303375	WINCH, RIGHT
18	2	0302950	HOSE ASSEMBLY, 100"
19	2	0400118	SCREW, 5/16"-18 x 3/4" HEX HD CAP
20	16	0400264	SCREW, 5/8"-11 x 2-1/4" HEX HD CAP
21	16	0400421	NUT, 5/8"-11 HEX NYLOK
22	2	0711395	ANGLE - WINCH MOUNTING
23	2	0711396	ANGLE - WINCH MOUNTING
24	2	0711397	ANGLE - WINCH MOUNTING
25	2	0711398	ANGLE - WINCH MOUNTING

Section VI - PARTS (cont'd)

LEFT CONTROL ASSEMBLY

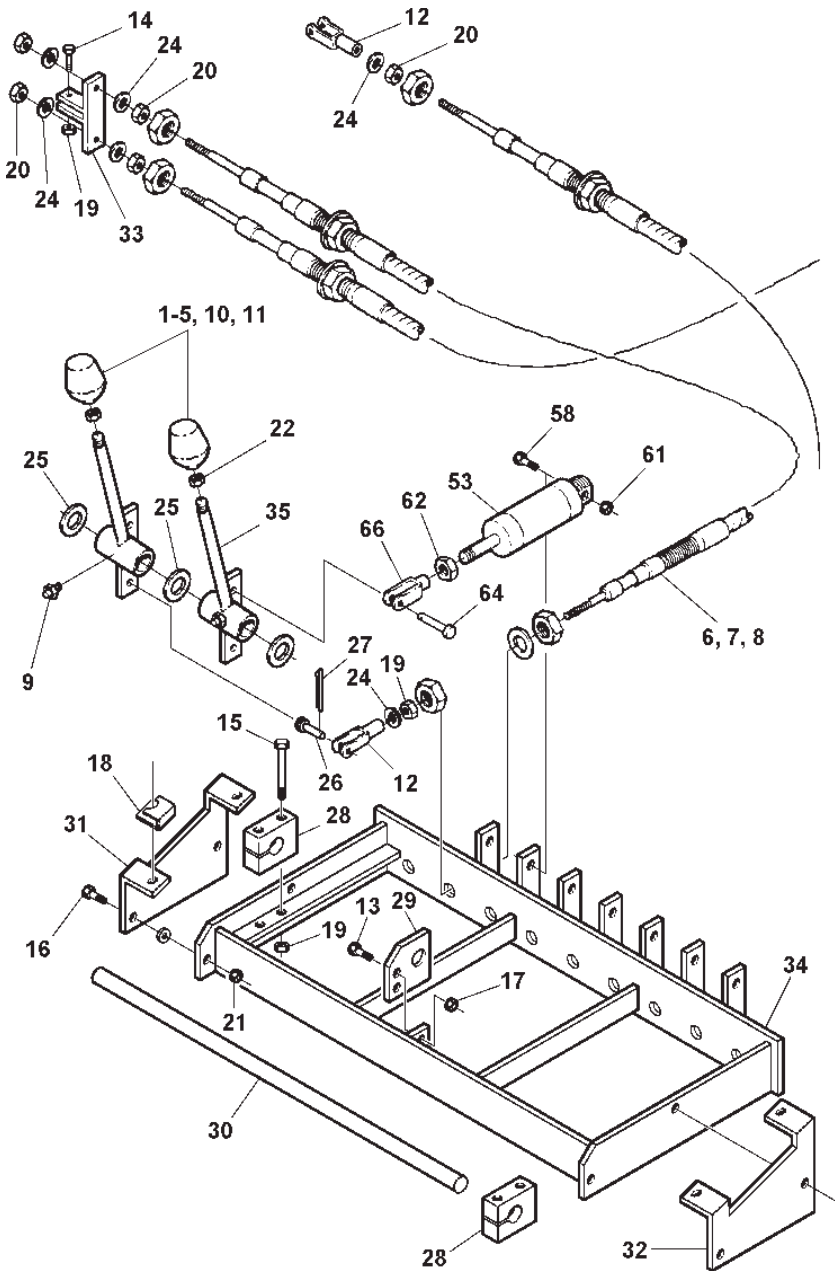

Section VI - PARTS (cont'd)

LEFT CONTROL ASSEMBLY

REF. NO.	NO. REQ'D	PART NUMBER	DESCRIPTION
1	1	0300341	CONTROL KNOB, W/L (UP/DOWN)
2	2	0300834	CONTROL KNOB, (IN/OUT)
3	1	0300835	CONTROL KNOB, BOOM (UP/DOWN)
4	2	0300836	CONTROL KNOB, JACK (UP/DOWN)
5	1	0300837	CONTROL KNOB, BOOM (IN/OUT)
6	1	0302453	CONTROL CABLE, 92"
7	4	0302454	CONTROL CABLE, 67"
8	4	0302455	CONTROL CABLE, 79"
9	9	0302726	GREASE FITTING, 1/4"-28 X 45 ∞
10	1	0302856	CONTROL KNOB, TILT (UP/DOWN)
11	1	0302917	CONTROL KNOB, W/L EXTEND (IN/OUT)
12	12	0303008	ADJUSTABLE CLEVIS
13	2	0400066	SCREW, 1/4"-20 X 3/4" HEX HD CAP
14	9	0400103	SCREW, 5/16"-18 X 1-1/4" HEX HD CAP
15	4	0400107	SCREW, 5/16"-18 X 2-1/2" HEX HD CAP
16	4	0400122	SCREW, 3/8"-16 X 1-1/4" HEX HD CAP
17	2	0400367	NUT, 1/4"-20 HEX NYLOK
18	4	0400379	NUT, 5/16"-18 "J" TINNERMAN
19	9	0400382	NUT, 5/16"-18 HEX NYLOK
20	36	0400383	NUT, 5/16"-24 HEX
21	10	0400392	NUT, 3/8"-16 HEX NYLOK
22	9	0400393	NUT, 3/8"-16 HEX JAM
23	4	0400451	WASHER, 1/4" FLAT
24	24	0400466	WASHER, 5/16" INTERNAL TOOTH
25	10	0400512	WASHER, 3/4" FLAT (SPECIAL)
26	9	0400532	CLEVIS PIN, 5/16" X 1"
27	9	0400541	COTTER PIN, 1/16" X 3/4"
28	2	0711235	CLAMP, SHAFT CONTROL BOX
29	1	0711245	PLATE, SHAFT SUPPORT
30	1	0711246	PIN, CONTROL BOX
31	1	0711284	SUPPORT, CONTROL (LEFT)
32	1	0711285	SUPPORT, CONTROL (RIGHT)
33	6	0801054	CONTROL CABLE CONNECTOR
34	1	0803182	CONTROL FRAME WELDMENT
35	9	0803294	CONTROL HANDLE WELDMENT

REMOTE CONTROL ASSEMBLY

REF. NO.	NO. REQ'D	PART NUMBER	DESCRIPTION
--	--	--	REMOTE CONTROL ASSEMBLY
36	10 / 16	0300166	WIRE CONNECTOR, SPADE
37	1	0301574	ELBOW, 4TB-4MP90
38	15 / 25	0301577	AIR HOSE, 1/4" O.D. (FT.)
39	2 / 4	0301610	CONNECTOR, 4TB-4MP
40	2 / 3	0301618	BRASS PLUG, 4MP
41	2	0302048	CABLE SEALING GRIP
42	2	0302340	HEX PIPE BUSHING
43	1	0302431	CONVOLUTED LOOM, 3/8" X 8"
44	35 / 65	0302434	CABLE TIE, 4" 18 LB.
45	1 / 2	0302677	BREATHER VENT, 2MP
46	16 / 28	0302678	ELBOW, 4TB-2MP
47	1	0302844	AIR SOLENOID VALVE (8)
--	1	0303479	AIR SOLENOID VALVE (14)
48	1	0303226	CIRCUIT BREAKER, HI-AMP WATERPROOF
49	1 / 2	0303235	TERMINAL BLOCK
50	1	0303250	POWER PAL, 15 POSITION
51	1	0303251	POWER PAL, 8 POSITION
52	8 / 20	0303322	ELECTRICAL CABLE, 16/10 SO (FT.)
53	4 / 7	0303335	AIR CYLINDER
54	1	0303363	AIR FILTER/REGULATOR
55	1	0303364	AIR LUBRICATOR
56	1	0303365	MOUNTING BRACKET
57	2 / 4	0400025	SCREW, #8-32 X 3/4" RD HD SLOTTED
58	4 / 7	0400057	SCREW, 1/4"-20 X 1-1/4" HEX HD CAP
59	2 / 4	0400078	SCREW, 1/4"-20 X 2" HEX HD CAP
60	2 / 4	0400351	HEX NUT & STAR WASHER, #8-32
61	6 / 11	0400367	NUT, 1/4"-20 HEX NYLOK
62	4 / 7	0400401	NUT, 7/16"-20 HEX JAM
63	2 / 4	0400451	WASHER, 1/4" FLAT
64	4 / 7	0400527	CLEVIS PIN, 5/16" X 5/8" COTTERLESS
65	1	0711277	SUPPORT, SOLENOID VALVE (8)
--	1	0711836	SUPPORT, SOLENOID VALVE (14)
66	4 / 7	0803181	CLEVIS WELDMENT
67	1	HA0132	GAUGE, 0-160 PSI

Section VI - PARTS (cont'd) RIGHT CONTROL ASSEMBLY

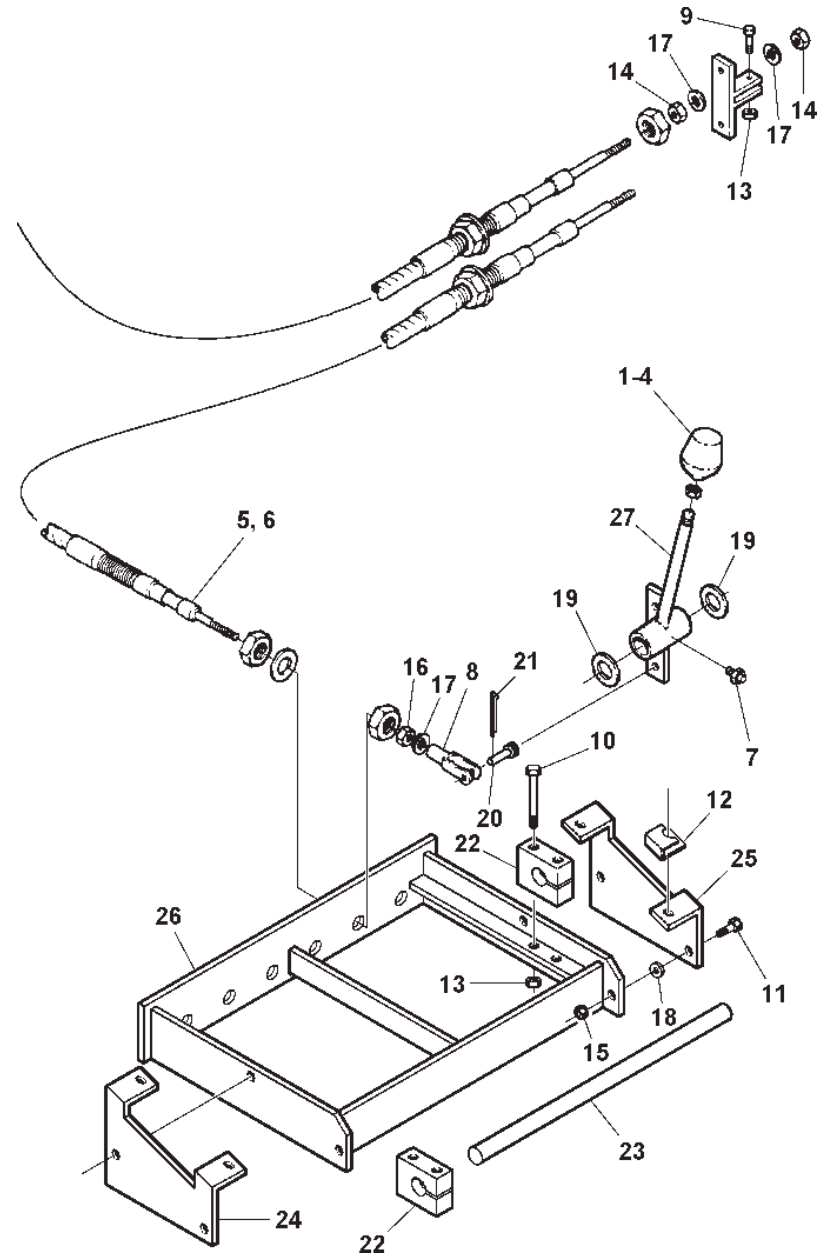

Section VI - PARTS (cont'd)

RIGHT CONTROL ASSEMBLY

REF. NO.	NO. REQ'D	PART NUMBER	DESCRIPTION
1	2	0300834	CONTROL KNOB, (IN/OUT)
2	1	0300835	CONTROL KNOB, BOOM (UP/DOWN)
3	2	0300836	CONTROL KNOB, JACK (UP/DOWN)
4	1	0300837	CONTROL KNOB, BOOM (IN/OUT)
5	3	0302453	CONTROL CABLE, 92"
6	3	0302455	CONTROL CABLE, 79"
7	6	0302726	GREASE FITTING, 1/4"-28 X 45∞
8	6	0303008	ADJUSTABLE CLEVIS
9	6	0400103	SCREW, 5/16"-18 X 1-1/4" HEX HD CAP
10	4	0400107	SCREW, 5/16"-18 X 2-1/2" HEX HD CAP
11	4	0400122	SCREW, 3/8"-16 X 1-1/4" HEX HD CAP
12	4	0400379	NUT, 5/16"-18 "J" TINNERMAN
13	10	0400382	NUT, 5/16"-18 HEX NYLOK
14	18	0400383	NUT, 5/16"-24 HEX
15	4	0400392	NUT, 3/8"-16 HEX NYLOK
16	6	0400393	NUT, 3/8"-16 HEX JAM
17	18	0400466	WASHER, 5/16" INTERNAL TOOTH
18	4	0400480	WASHER, 3/8" FLAT
19	7	0400512	WASHER, 3/4" FLAT (SPECIAL)
20	6	0400532	CLEVIS PIN, 5/16" X 1"
21	6	0400541	COTTER PIN, 1/16" X 3/4"
22	2	0711235	CLAMP, SHAFT CONTROL BOX
23	1	0711247	PIN, CONTROL BOX
24	1	0711284	SUPPORT, CONTROL (LEFT)
25	1	0711285	SUPPORT, CONTROL (RIGHT)
26	1	0803183	CONTROL FRAME WELDMENT
27	6	0803294	CONTROL HANDLE WELDMENT

Section VI - PARTS (cont'd)

REAR SPADE HYDRAULICS

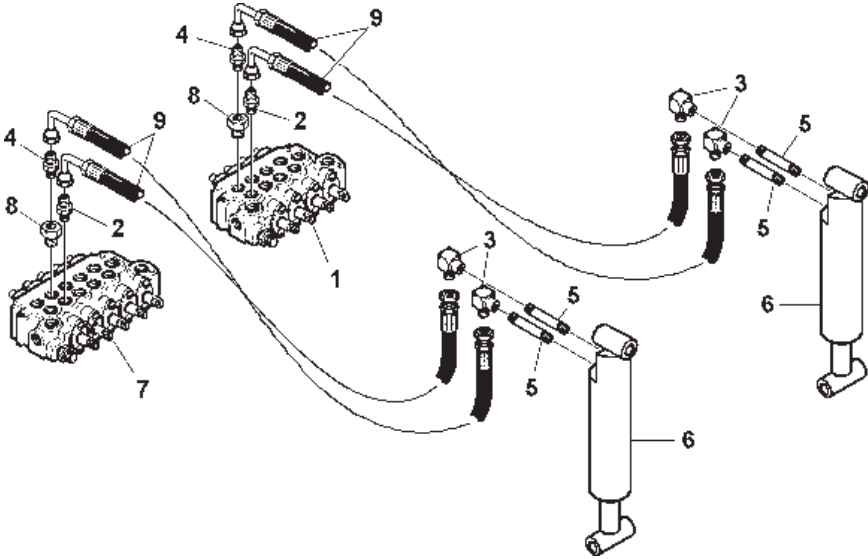

REF. NO.	NO. REQ'D	PART NUMBER	DESCRIPTION
1	REF.	REF.	CONTROL VALVE
2	2	0300044	CONNECTOR, 6MJ-6MB
3	4	0300689	STREET ELBOW, STEEL, 8MJ-8FP90
4	2	0301522	CONNECTOR 6MJ-6MB
5	4	0301819	NIPPLE, BLACK PIPE, 1/2" X 4-1/2"
6	2	0302616	HYDRAULIC CYLINDER
7	REF.	REF.	CONTROL VALVE
8	2	0303017	CONNECTOR, 8MB-6FB
9	2	0303175	HOSE ASSEMBLY, 102"

Section VI - PARTS (cont'd)

HYDRAULIC CYLINDERS

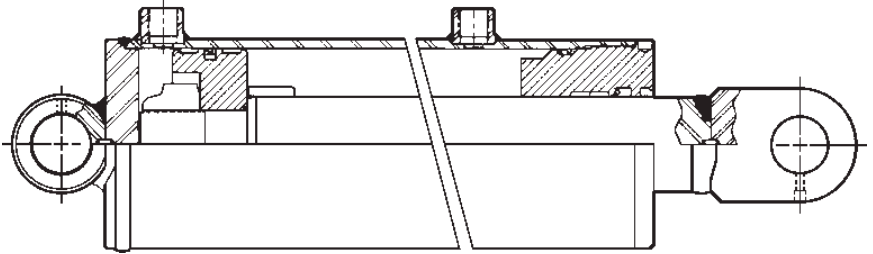

REF. NO.	NO. REQ'D	PART NUMBER	DESCRIPTION
1	2	0303091	BOOM ELEVATION CYLINDER (COMPLETE)
2	1	14207	SEAL KIT, BOOM ELEVATION CYLINDER

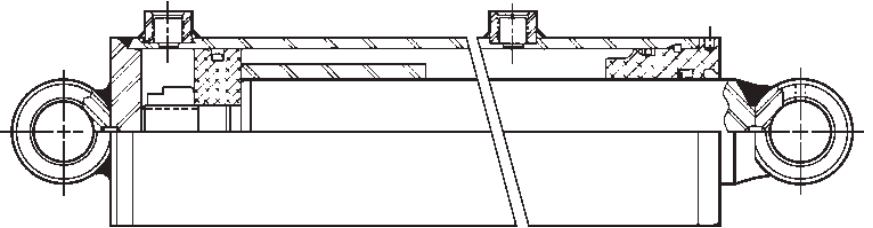

REF. NO.	NO. REQ'D	PART NUMBER	DESCRIPTION
1	1	0302614	BOOM EXTENSION CYLINDER (COMPLETE)
2	1	0304503	SEAL KIT, BOOM EXTENSION CYLINDER

Section VI - PARTS (cont'd)

HYDRAULIC CYLINDERS

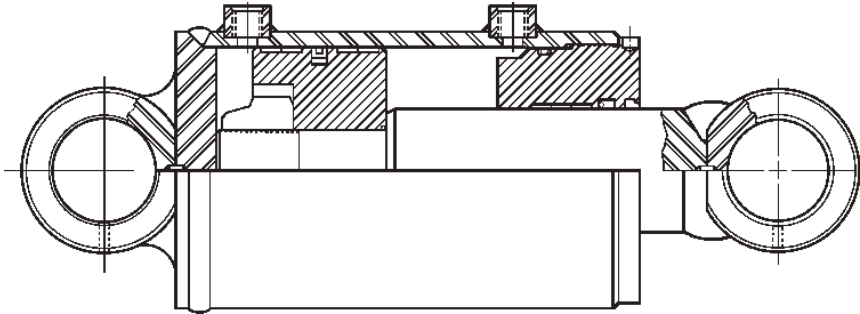

REF. NO.	NO. REQ'D	PART NUMBER	DESCRIPTION
1	1	0302791	CYLINDER, UNDERLIFT TILT (COMPLETE)
2	1	0304488	SEAL KIT, UNDERLIFT TILT CYLINDER

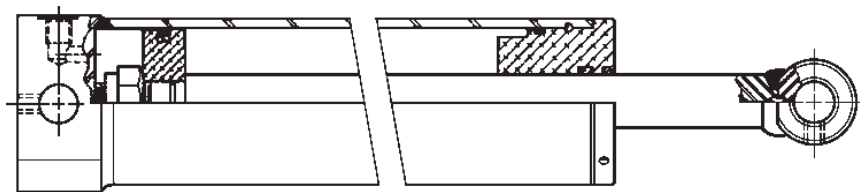

REF. NO.	NO. REQ'D	PART NUMBER	DESCRIPTION
1	1	0303331	CYLINDER, UNDERLIFT EXTEN. (COMPLETE)
2	1	030xxx	SEAL KIT, UNDERIFT EXTENSION CYLINDER

Section VI - PARTS (cont'd)

HYDRAULIC CYLINDERS

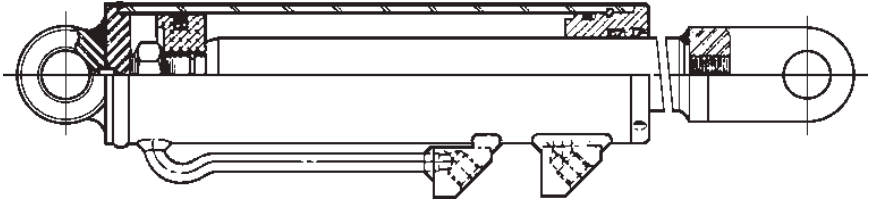

REF. NO.	NO. REQ'D	PART NUMBER	DESCRIPTION
1	1	0301765	CYLINDER, UNDERLIFT FOLD (COMPLETE)
2	1	0304244	SEAL KIT, UNDERLIFT FOLD CYLINDER

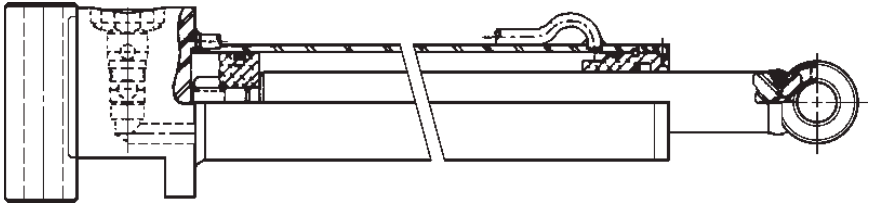

REF. NO.	NO. REQ'D	PART NUMBER	DESCRIPTION
1	2	0302616	CYLINDER, REAR SPADE (COMPLETE)
2	1	0304244	SEAL KIT, REAR SPADE CYLINDER

Section VI - PARTS (cont'd)

GLAD HAND KIT

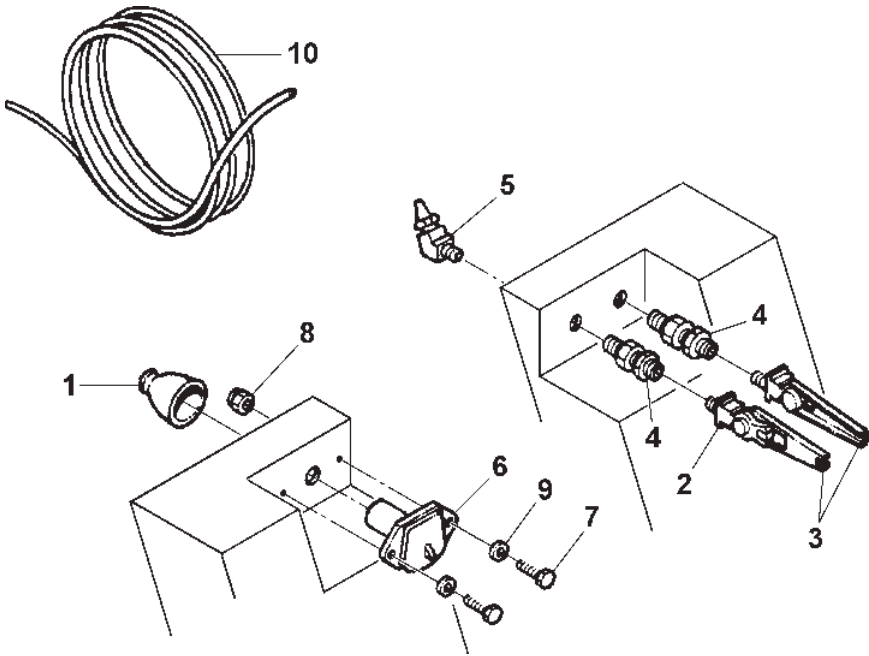

REF. NO.	NO. REQ'D	PART NUMBER	DESCRIPTION
1	1	0301909	RECEPTACLE BOOT
2	2	0301944	GLAD HAND COUPLING
3	2	0301945	GLAD HAND PLUG
4	2	0301946	BULKHEAD CONNECTOR
5	2	0301947	ADAPTER, 1/4" NPM X 3/8" SYN. HOSE
6	1	0301948	HD 7-WAY TRAILER CONNECTOR
7	2	0400070	SCREW, 1/4"-20 X 1" HEX HD CAP
8	2	0400367	NUT, 1/4"-20 HEX NYLOK
9	2	0400451	WASHER, 1/4" FLAT
10	2	0703795	AIR HOSE, 3/8" X 48" SYN FLEX

Section VI - PARTS (cont'd)

LIFT ADAPTERS

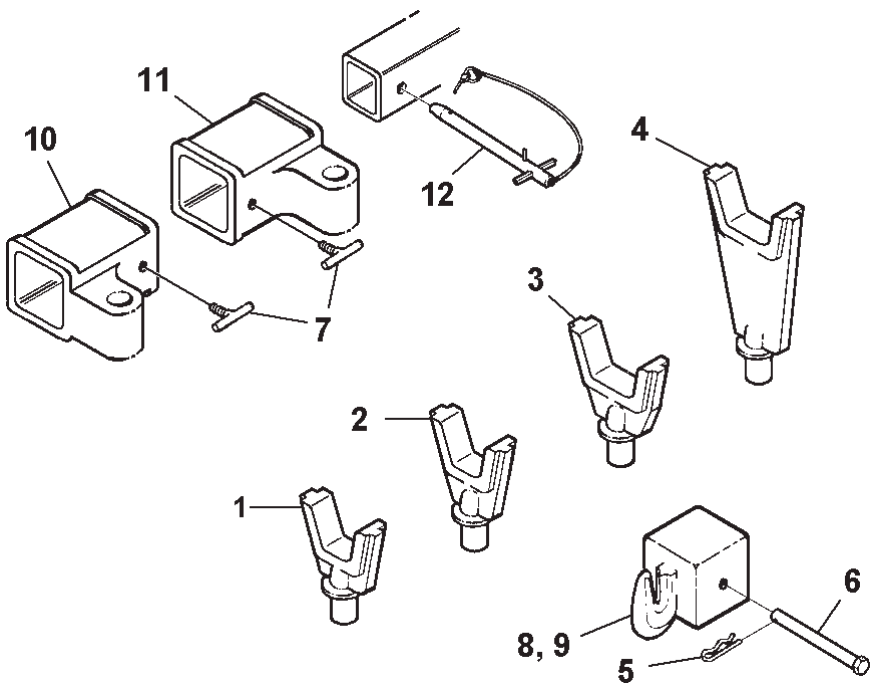

REF. NO.	NO. REQ'D	PART NUMBER	DESCRIPTION
1	2	0200018	FORK, SHORT (3" OPENING)
2	2	0200020	FORK, MEDIUM (3" OPENING)
3	2	0200021	FORK, MEDIUM (4-1/2" OPENING)
4	2	0200023	FORK, LONG (4-1/2" OPENING)
5	2	0400585	HAIR PIN COTTER, 1-1/4"
6	2	0711001	BOLT, MODIFIED 5/8"-11 X 5" WITH HOLE
7	2	0800590	TEE HANDLE, FORK ADAPTER
8	1	0802251	CHAIN HOOK ADAPTER, RT
9	1	0802252	CHAIN HOOK ADAPTER, LT
10	1	0803580	OFFSET FORK ADAPTER, LT
11	1	0803581	OFFSET FORK ADAPTER, RT
12	2	0902378	RETAINER PIN ASSEMBLY

Section VI - PARTS (cont'd)

OUTER CROSSTUBE ASSEMBLY

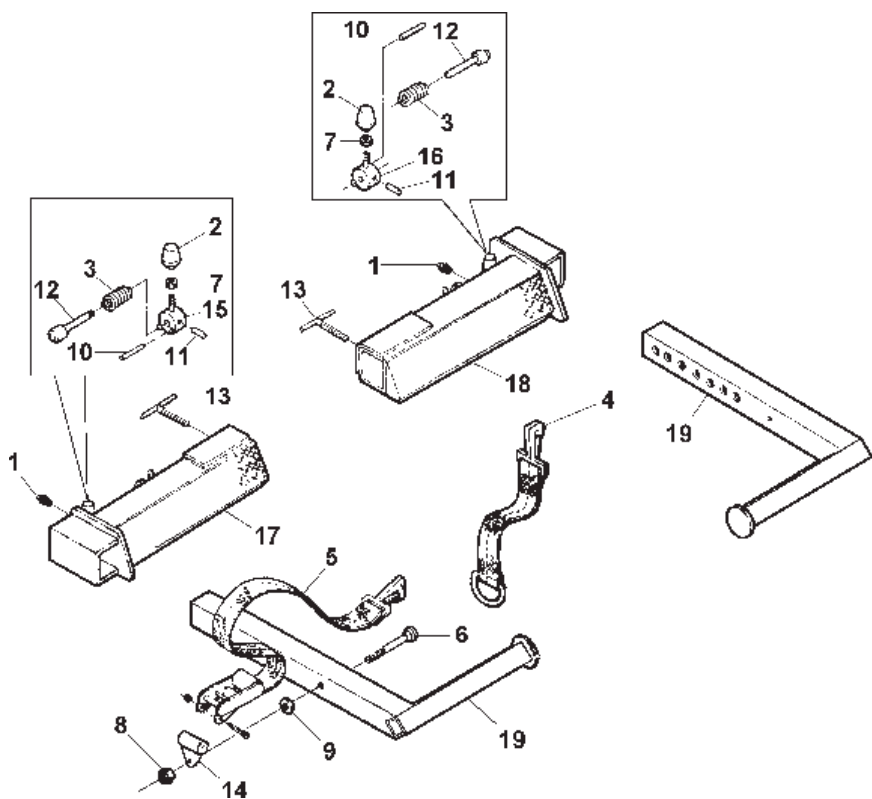

Section VI - PARTS (cont'd)

OUTER CROSSTUBE ASSEMBLY

REF. NO.	NO. REQ'D	PART NUMBER	DESCRIPTION
1	2	0300113	GREASE FITTING
2	2	0300341	KNOB, "L" BAR LOCK CONTROL
3	2	0301417	SPRING, PLUNGER PIN
4	2	0301681	EXTENSION, TIRE RESTRAINT
5	2	0301682	TIRE RESTRAINT
6	2	0400269	BOLT, 5/8"-11 X 4-1/2" CARRIAGE
7	2	0400393	NUT, 3/8"-16 HEX JAM
8	2	0400421	NUT, 5/8"-11 HEX NYLOK
9	2	0400506	WASHER, 5/8" FLAT
10	2	0400559	PIN, 3/16" X 1" ROLL
11	2	0400560	PIN, 5/32" X 1" ROLL
12	2	0706688	PIN, PLUNGER
13	4	0800590	HANDLE, "T"
14	2	0800839	BRACKET, RESTRAINT ASSEMBLY PIVOT
15	1	0802069	HANDLE, L.H. PLUNGER PIN
16	1	0802070	HANDLE, R.H. PLUNGER PIN
17	1	0802231	CROSSBAR, LEFT OUTER
18	1	0802232	CROSSBAR, RIGHT OUTER
19	2	0802606	TIRE RESTRAINT, MEDIUM

Section VI - PARTS (cont'd)

KING PIN ADAPTER

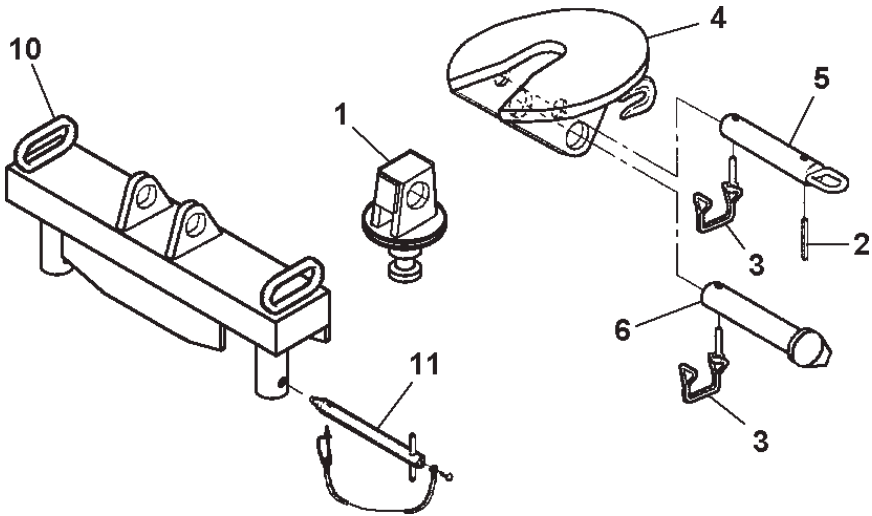

REF. NO.	NO. REQ'D	PART NUMBER	DESCRIPTION
1	1	0803605	KING PIN ADAPTER WELDMENT
--	--	0902782	FIFTH WHEEL ADAPTER (COMPLETE)
2	1	0400555	ROLL PIN, 3/8" X 1-1/2"
3	2	HD1259	PIN SNAPPER
4	1	VA0660	FIFTH WHEEL PIVOT PLATE WELDMENT
5	1	VA0661	PULL PIN WELDMENT
6	1	VA0662	PIVOT PIN WELDMENT
--	--	124002211	PINTLE HOOK KIT (COMPLETE)
7	1	0302198	PINTLE HOOK (NOT SHOWN)
8	4	0400176	SCREW, 1/2"-13 X 1" HEX HD CAP
9	4	0400491	LOCKWASHER, 1/2" HELICAL
10	1	0803604	5TH WHEEL, KING PIN ADAPTER & PINTLE HOOK BRACKET
11	2	0902378	RETAINING PIN ASSEMBLY

Section VI - PARTS (cont'd)

LIGHT KIT

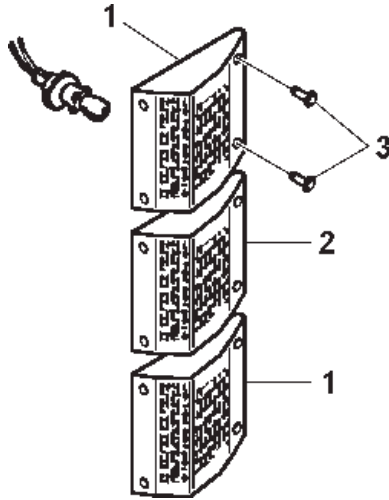

REF. NO.	NO. REQ'D	PART NUMBER	DESCRIPTION
1	4	0302542	LIGHT, STOP & TURN (COMPLETE)
2	2	0302543	LIGHT, BACK-UP (COMPLETE)
3	24	0400025	SCREW, #8-32 x 3/4" RD HD SLOTTED

Section VI - PARTS (cont'd)

LIGHT KIT

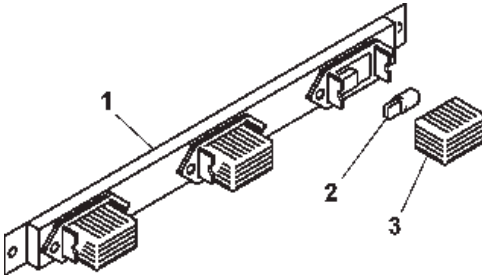

REF. NO.	PART NUMBER	DESCRIPTION
1	0300442	3-LIGHT BAR ASSEMBLY (COMPLETE)
2	0300507	BULB, MARKER LIGHT
3	0200511	LENS, 3-LIGHT BAR

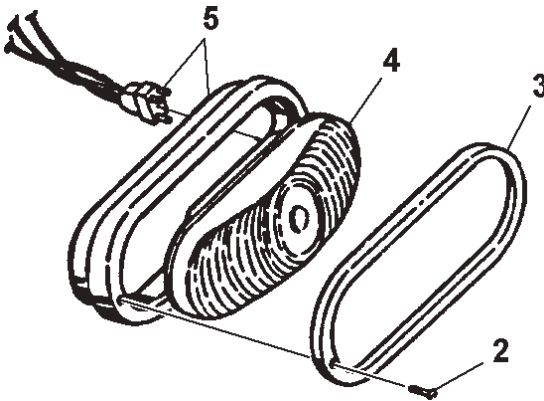

REF. NO.	PART NUMBER	DESCRIPTION
1	0301390	LIGHT, TURN (COMPLETE)
2	0304123	BEZEL MOUNTING SCREW
3	0304124	CHROME BEZEL
4	0304125	LENS & BULB ASSEMBLY
5	0304126	GROMMET & PLUG KIT

Section VI - PARTS (cont'd) LIGHT KIT

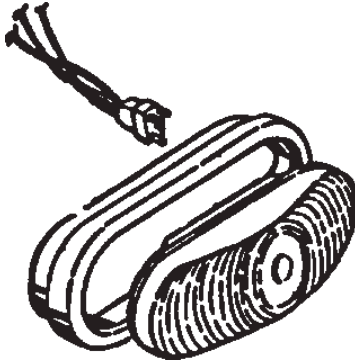

REF. NO.	PART NUMBER	DESCRIPTION
1	0302201	LIGHT, FLOOD (COMPLETE)

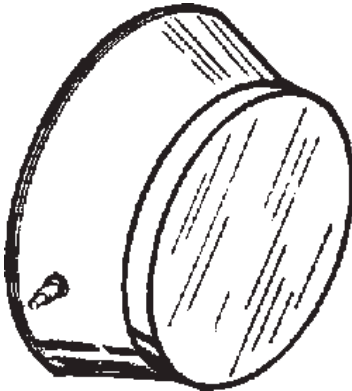

REF. NO.	PART NUMBER	DESCRIPTION
1	0302544	LIGHT, DOME (COMPLETE)

Section VI - PARTS (cont'd)

LIGHT KIT

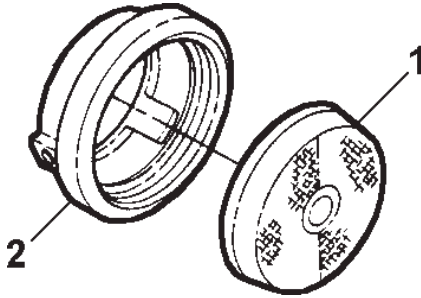

REF. NO.	PART NUMBER	DESCRIPTION
1	0301740	GROMMET & PLUG, MARKER LIGHT
2	0301741	SEALED MARKER LIGHT, RED
3	0301742	SEALED MARKER LIGHT, AMBER

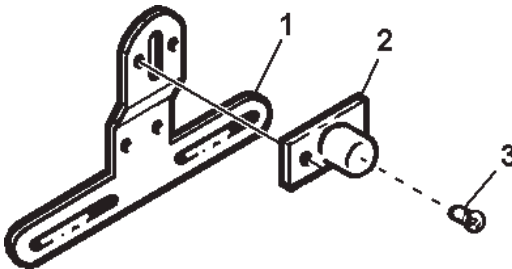

REF. NO.	PART NUMBER	DESCRIPTION
1	0300076	BRACKET, LICENSE PLATE
2	0300273	LICENSE PLATE ILLUMINATOR (COMPLETE)
3	0300512	BULB, LICENSE PLATE ILLUMINATOR

Section VI - PARTS (cont'd) LIGHT KIT

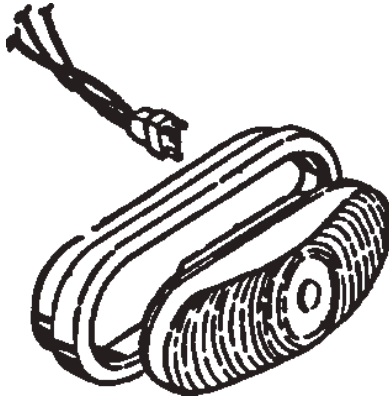

REF. NO.	PART NUMBER	DESCRIPTION
1	0302611	LIGHT, AMBER MARKER (COMPLETE)

Section VII - INSTALLATION

7.1 SWITCH PANEL & PTO SHIFTER INSTALLATION

The Switch Panel (0302690) is generally located beside the driver's seat or in the overhead console, and controls the light bar, flood lights, auxiliary lights, control station lights, and lower work lights. Refer to Figure 3.2. The air shift PTO control knob and indicator light are generally located on dash panel in cab. Refer to Figure 4.1.

- (a) Attach switch panel wiring harness (0302746). Refer to electrical schematic & switch panel wiring, pages VIII-1 & VIII-2.
- (b) Install fittings from PTO kit to PTO shifter valve. Install nylon tubing to fittings on valve. See Figure 7.1.

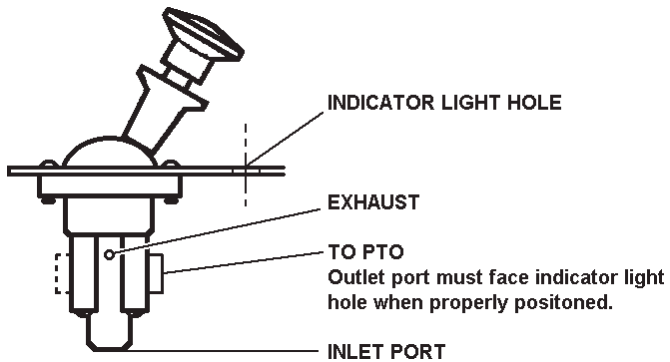

FIGURE 7.1

- (c) Install PTO shifter valve in dash panel.
- (d) Thread electrical harness and nylon tubing through holes drilled in cab floor and mount switch panel to floor using six (6) 1/4"-20 x 2-1/4" slotted head screws and nylon lock nuts from switch panel kit.
- (e) Install pressure protection valve at air supply point (air tank). See PTO instructions. Install tee fitting (furnished by customer) in outlet port of pressure protection valve.

Section VII - INSTALLATION (cont'd)

7.1 SWITCH PANEL & PTO SHIFTER INSTALLATION (cont'd)

- (f) Install nylon tubing from inlet port on PTO shifter to tee fitting at pressure protection valve. (NOTE: Other side of tee fitting is connected to wrecker winch air shifter cylinders.)
- (g) Connect outlet line from PTO shifter valve to PTO after PTO is installed.

7.2 PTO INSTALLATION

- (a) Drain transmission oil.
- (b) Disengage PTO (gears should turn freely).
- (c) Install PTO to truck transmission with supplied gasket and stud kit. Refer to PTO Owner's Manual for proper installation procedures. (Ideally, PTO should be mounted to transmission so that pump, when mounted to PTO, is rear of truck cab.)

7.3 PUMP INSTALLATION

Mount pump to PTO in a position which allows pump fittings to be horizontal (parallel with ground). Secure with hardware furnished in PTO kit.



**REFILL TRANSMISSION
WITH OIL BEFORE OPERATING.**

7.4 PREPARATION OF TRUCK FRAME

Before installing body mounting angles, check the area from the cab rearward for any obstructions that would interfere with the installation of the body.

Section VII - INSTALLATION (cont'd)

7.4 PREPARATION OF TRUCK FRAME (cont'd)



RELOCATING EXHAUST SYSTEM COMPONENTS, ELECTRICAL COMPONENTS, BRAKING SYSTEM COMPONENTS, AND/OR FUEL SYSTEM COMPONENTS MUST BE PERFORMED BY QUALIFIED PERSONS ONLY!

ALL MODIFICATIONS COVERED BY FEDERAL AND STATE SAFETY CODES MUST BE CERTIFIED AFTER THE MODIFICATION IS COMPLETED.

- (a) Cut chassis frame rails as shown in Figure 7.2.

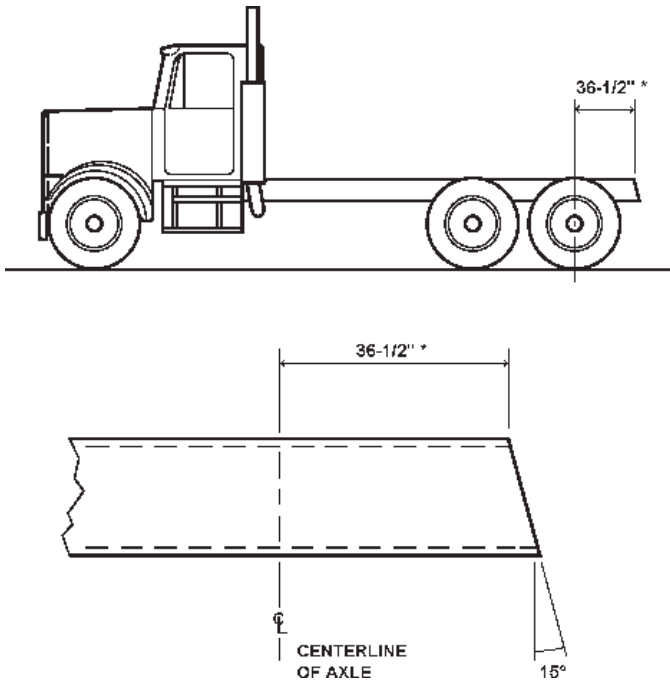

FIGURE 7.2

Section VII - INSTALLATION (cont'd)

7.4 PREPARATION OF TRUCK FRAME (cont'd)

(b) Notch frame rails as shown in Figure 7.3.

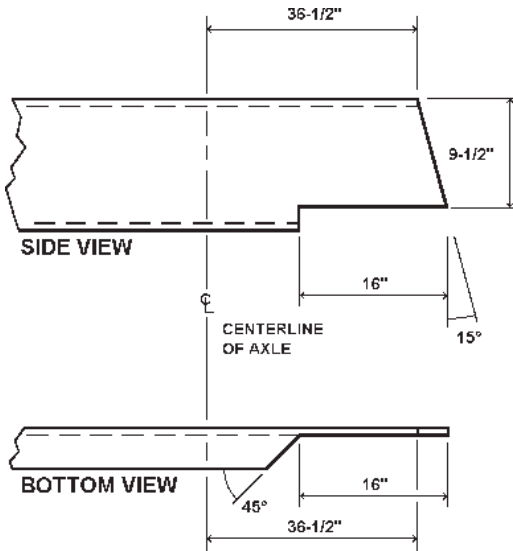

FIGURE 7.3

7.5 MOUNTING PLATE INSTALLATION

(a) Clamp mounting plates to chassis frame as shown in Figure 7.4.

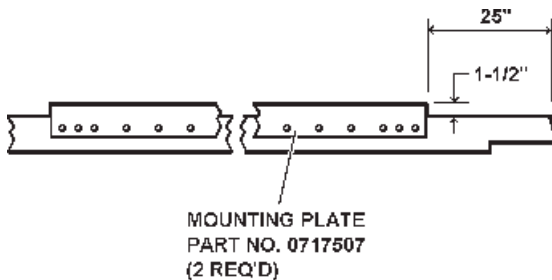

FIGURE 7.4

(b) Using holes in the mounting plates as a guide, drill the chassis frame for 3/4" mounting bolts.

Section VII - INSTALLATION (cont'd)

7.5 MOUNTING PLATE INSTALLATION

NOTE
ALL EXISTING CROSSMEMBER BOLTS MUST BE
REPLACED IN THEIR ORIGINAL LOCATIONS.



**DO NOT WELD PLATES TO CHASSIS FRAME RAILS!
D.O.T. REGULATIONS PROHIBIT ANY WELDING
TO CHASSIS FRAME.**

NOTE
IT MAY BE NECESSARY TO NOTCH MOUNTING PLATES TO
CLEAR SPRING HANGERS AND OTHER UNMOVABLE OBJECTS.

- (c) Attach mounting plates to frame using 3/4"-10 x 2-1/2" Grade 8 mounting bolts and nylon lock nuts from body mounting hardware kit.

7.6 TAILGATE MOUNTING ANGLE INSTALLATION

- (a) Securely clamp tailgate mounting angles to the outside of each chassis frame rail. Make sure the horizontal leg of each angle is facing out. See Figure 7.5.

Section VII - INSTALLATION (cont'd)

7.6 TAILGATE MOUNTING ANGLE INSTALLATION (cont'd)

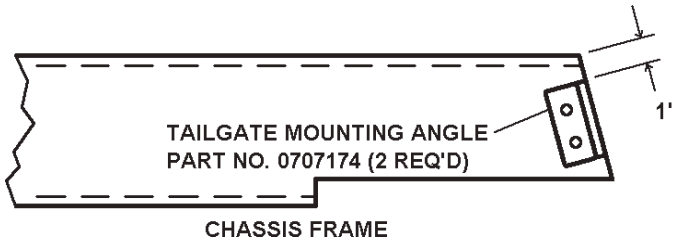

FIGURE 7.5

- (b) Using holes in tailgate mounting angles as a guide, drill chassis frame for 3/4" mounting bolts.



**DO NOT WELD ANGLES TO CHASSIS FRAME RAILS!
D.O.T. REGULATIONS PROHIBIT ANY WELDING
TO CHASSIS FRAME.**

- (c) Attach tailgate mounting angles to frame using 3/4"-10 x 2-1/2" Grade 8 mounting bolts and nylon lock nuts from body mounting hardware kit.

7.7 WRECKER ASSEMBLY INSTALLATION

- (a) Identify the following wires in the truck cab wiring harness:
1. Running Lights
 2. Back-Up Lights
 3. Right Turn & Stop Light
 4. Left Turn & Stop Light

If possible, cut the wires long enough to connect directly to the junction box in left tool compartment.

Section VII - INSTALLATION (cont'd)

7.7 WRECKER ASSEMBLY INSTALLATION (cont'd)

- (b) Using a suitable lifting device, position the wrecker assembly on the chassis frame. Lift front of subframe sufficiently to ensure that subframe is flat on chassis frame at rear, and that tailgate mounting angles are against tailgate. Weld tailgate mounting angles to the tailgate with a continuous weld. See Figure 7.6.



FIGURE 7.6

- (c) Lower front of subframe until it rests flat on chassis frame between mounting plates. If subframe is not flat on chassis frame, proceed as follows:
1. Take a hydraulic jack and weld a U-shaped piece of steel to the pad on the ram. This may be removed from jack after installation, if desired.
 2. Place the jack on top of subframe at the center of the mounting plate and secure in place with a chain that completely encircles the subframe and chassis frame. Fasten securely. See Figure 7.6. Extend jack until the wrecker subframe rests completely on the chassis frame. Weld the wrecker subframe to the mounting plate with a continuous weld. Repeat this procedure on the opposite side of chassis. **NOTE:** If the chassis width is wider than the wrecker subframe, shims may be added between the mounting plates and subframe. Add symmetrically to both sides.

Section VII - INSTALLATION (cont'd)

7.7 WRECKER ASSEMBLY INSTALLATION (cont'd)

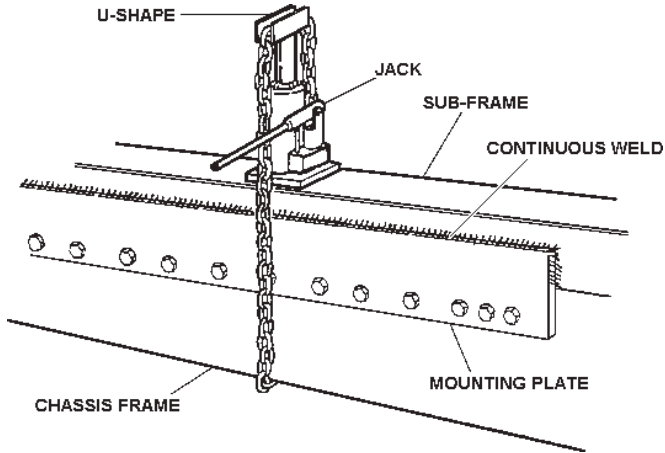

FIGURE 7.7

7.8 HYDRAULIC HOSE HOOK-UP

Refer to Pump, Valve, and Filter Hydraulics, page VI-16 and Hydraulic Schematic, page VIII-4.

- (a) Install hydraulic fittings from pump kit to hydraulic pump. Flanged fittings and hose barbs attach to suction side of pump. Threaded elbows attach to pressure or output side. Fittings should be installed so they are horizontal or parallel to the ground. Fittings must be tight to prevent oil leakage.
- (b) Attach 1-1/2" suction hoses from hose barbs on bottom of oil reservoir to barbed fittings on the pump. Use hose clamps supplied in pump kit.
- (c) Attach two pressure hose assemblies from control valves to the threaded fittings on pressure side of pump. Fittings must be tight to prevent oil leakage.
- (d) Fill the hydraulic reservoir with hydraulic oil selected from Section 5.4 (a), Summary Of Required Lubricants, page V-3, until the oil level is in the center of the sight gauge on the reservoir.

Section VII - INSTALLATION (cont'd)

7.9 WINCH AIR SHIFTER

Connect nylon line from winch air shifter cylinders to tee fitting at pressure protection valve at air supply point.

7.10 AIR CONTROL MANIFOLD

Connect nylon line from air regulator, located in left rear control compartment, to tee fitting at pressure protection valve at the air supply point. Set air pressure at the regulator to 50-60 pounds. Refer to Section 5.7, Filter / Regulator Operation And Service, pages V-6 and V-7.

NOTE
SECURE ALL LINES AND HOSES TO FRAME
WITH CLAMPS AND NYLON TIES.

7.11 WIRING HOOK-UP

- (a) Complete wiring hook-ups between truck cab and wrecker body. Holes are provided in the left front of the wrecker body for the wiring harness to pass through. Wires are then attached to the proper locations in the junction boxes located in the left front tool compartment. Refer to Electrical Schematic, page VIII-1.
- (b) Mount light bar assembly, if applicable. It may be necessary to add another hole in body to accommodate light bar wiring harness.

7.12 GLAD HAND HOOK-UP

The wrecker assembly is furnished with glad hand and electrical receptacles installed in the tailgate. It is the customers responsibility to attach these units to the truck air and electrical systems.

7.13 INSTALLATION CHECK

Check all installation points for completeness and correct assembly.

- (a) Mounting plates to chassis frame and wrecker subframe.
- (b) Hydraulic and air line hook-ups. Oil in reservoir.
- (c) Wiring harness hook-up. Check light operation.

Section VII - INSTALLATION (cont'd)

7.14 WINCH CABLE INSTALLATION

Installation is now complete except for winch cable installation.



**DO NOT COMPLETE THIS STEP UNTIL YOU
STUDY SECTION III - OPERATIONAL FUNCTIONS
AND SECTION IV - OPERATING INSTRUCTIONS.**

**AFTER BECOMING THOROUGHLY FAMILIAR
WITH ALL OPERATIONS, PROCEED WITH
WINCH CABLE INSTALLATION.**

- (a) Thread ends of wire rope through boom end swivels and attach to winch drums with fasteners provided. Left wire rope to rear winch and right wire rope to front winch. NOTE: Wire rope winds in on bottom side of winch drums and should be wound on drums under load so cable will be tight on drums. Operate winches from controls at left rear control station.

- (b) Attach cable hooks to spring loaded loops on tower when not in use.

Section VIII - SCHEMATICS

ELECTRICAL

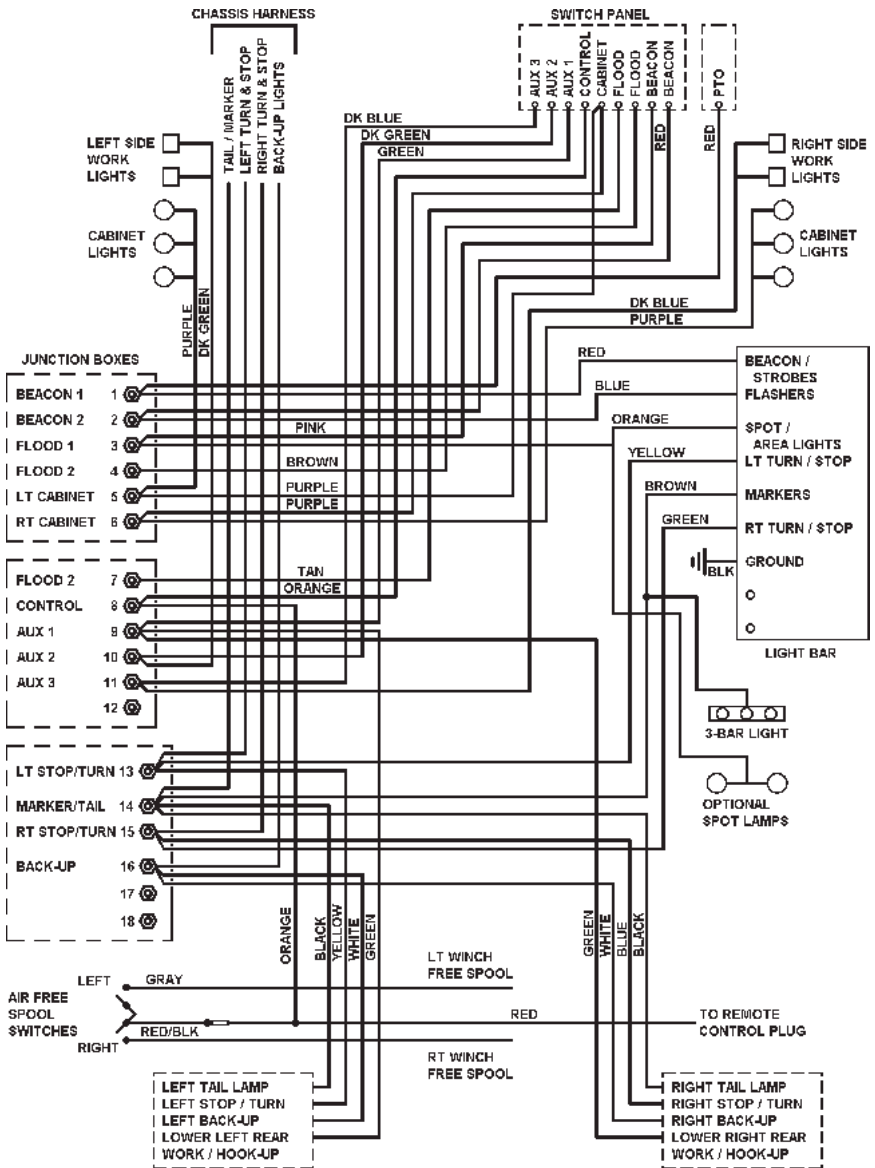

Section VIII - SCHEMATICS (cont'd)

SWITCH PANEL WIRING

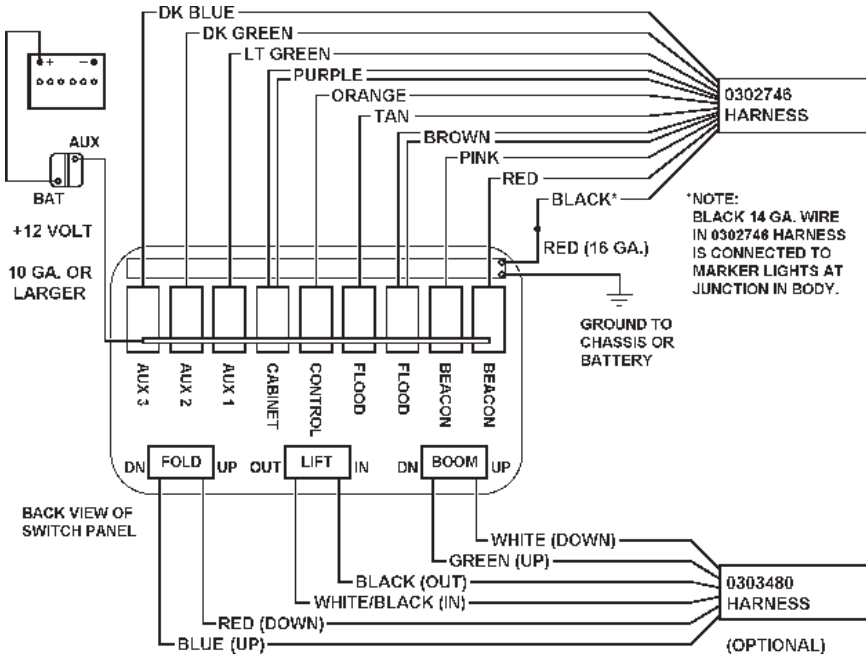

Section VIII - SCHEMATICS (cont'd)

REMOTE CONTROL ELECTRICAL

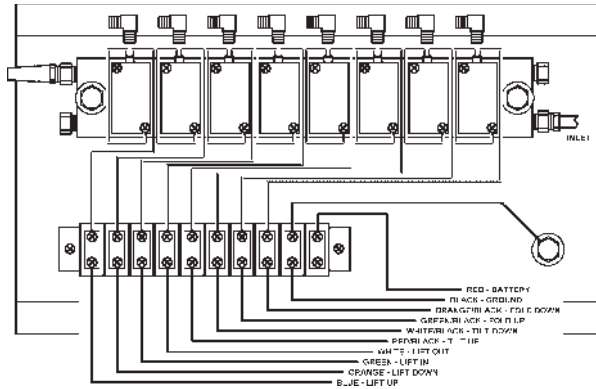

8-POSITION POWER PAL

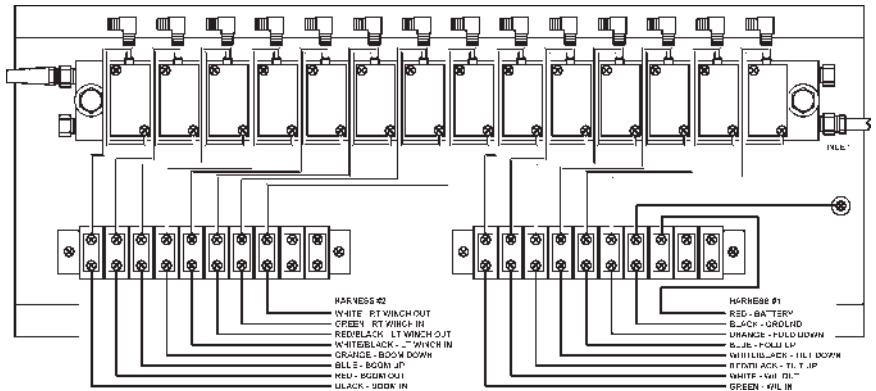

15-POSITION POWER PAL

Section VIII - SCHEMATICS (cont'd)

HYDRAULIC

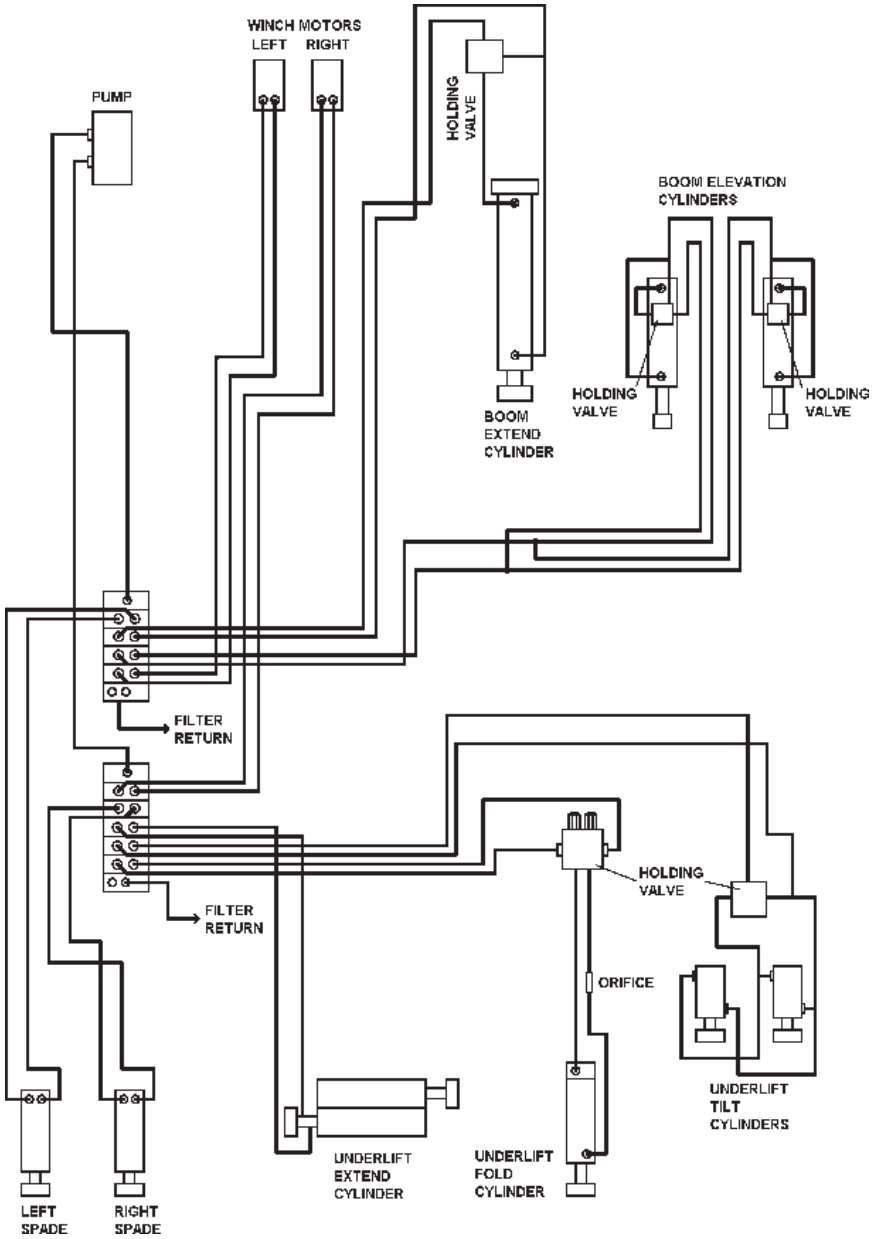

CENTURY®

Miller Industries Towing Equipment Inc.

8503 Hilltop Drive • Ooltewah, Tennessee 37363 • (423) 238-4171

www.millerind.com