

# CENTURY

HYDRAULIC

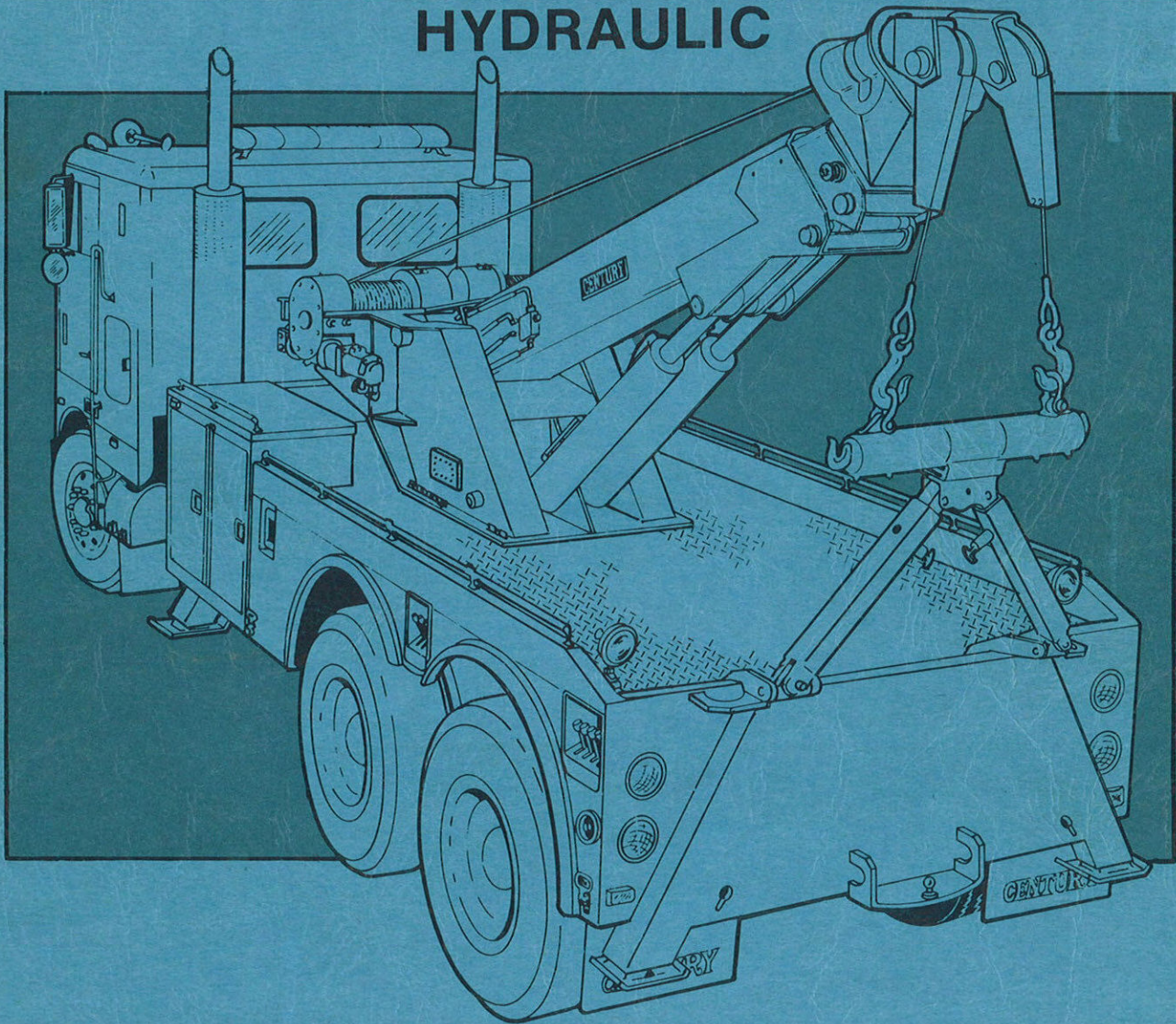

## OWNERS MANUAL

# 1040

Installation, Operation,  
Maintenance & Parts

CENTURY  
WRECKER  
CORPORATION

1-75 At Ooltewah Exit • P. O. Box 120 • Ooltewah (Chattanooga), TN 37363 • Telephone: (615) 238-4171 or (615) 267-1831  
FORM NO. 0500135 12 81  
PRICE \$15.00

*WINCH CABLES 0301215*



This manual has been prepared for the owner and operators of the CENTURY WRECKER CORPORATION 1040 Hydraulic Wrecker. Its purpose, aside from operating and maintenance instructions, is to promote safety through the use of accepted operating procedures.

Read all instructions thoroughly before operating the wrecker.

Also contained in this manual is a parts section for the 1040 Hydraulic Wrecker. Use of other than factory or factory authorized parts will render the warranty void.

# WARRANTY

CENTURY WRECKER CORPORATION warrants each new CENTURY Wrecker to be free from defects in material and workmanship for a period of one (1) year from date of purchase.

The obligation under this warranty, statutory or otherwise, is limited to the replacement or repair at our factory, or at a point designated by us, of such part or parts as shall appear to us upon inspection to be defective in material or workmanship.

This warranty does not obligate CENTURY WRECKER CORPORATION to bear the cost of labor or transportation charges in connection with the replacement or repair of any parts found to be defective, nor shall it apply to a product upon which repairs or alterations have been made unless authorized by us.

CENTURY WRECKER CORPORATION makes no warranty with respect to accessories or wire rope (cable), such being subject to the warranties of their respective manufacturers. CENTURY WRECKER CORPORATION shall in no event be liable for consequential damages or contingent liabilities arising out of the failure of any parts or products to operate properly. No implied, express, or statutory warranty other than stated herein is made or authorized to be made by or for us.

CENTURY WRECKER CORPORATION, whose policy is one of continuous improvement, reserves the right to improve its products through changes in design or materials as it may deem desirable without being obligated to incorporate such changes in products of prior manufacture.

It is expressly understood that there is no implied warranty that CENTURY Wreckers shall be fit for the purpose of lifting or moving **Persons** or other improper use, and there is no implied warranty of merchantability for such purpose.

This warranty is not transferable and will become effective only upon completion and mailing in of the Warranty Card to CENTURY WRECKER CORPORATION.

SERIAL NUMBER

**CENTURY  
WRECKER  
CORPORATION**

1-75 AT OOLTEWAH EXIT • P. O. BOX 120 • CHATTANOOGA (OOLTEWAH), TN 37363  
TELEPHONE (615) 238-4171 or (615) 267-1831



# TABLE OF CONTENTS

<b>Section I</b>	
SAFETY PRECAUTIONS . . . . .	1
<b>Section II</b>	
OPERATIONAL FUNCTIONS . . . . .	2
<b>Section III</b>	
OPERATING INSTRUCTIONS . . . . .	3
<b>Section IV</b>	
MAINTENANCE . . . . .	4-5-6
<b>Section V</b>	
INSTALLATION . . . . .	7-8-9
<b>Section VI</b>	
PARTS . . . . .	10-12
BODY, 1040 . . . . .	10
1040 WRECKER FRAME . . . . .	11
BOOM . . . . .	12
HYDRAULICS	
VALVE . . . . .	13
ELEVATION CYLINDER . . . . .	14
EXTENSION CYLINDER . . . . .	15
EXTERNAL EXTENSION . . . . .	16
JACK . . . . .	17
WINCH MOTORS . . . . .	18
PUMP AND FILTER . . . . .	19
BOOM END SWIVEL . . . . .	20
DRAG BRAKE ASSEMBLY . . . . .	20
THROTTLE CONTROL CABLE . . . . .	20
HYDRAULIC WINCH . . . . .	21
WIRING HARNESS, 1040 . . . . .	22
LIGHT KIT . . . . .	23
WIRING INSTALLATION . . . . .	24
VALVE CONTROLS . . . . .	25-26-27-31
PUMP PRESSURE ADJUSTMENT . . . . .	28
OPTIONAL EQUIPMENT	
FREE SPOOL CLUTCH CONTROL . . . . .	29
FRONT OUTRIGGER . . . . .	30
FRONT OUTRIGGER CONTROL . . . . .	31
"D" RING . . . . .	32

# Section 1 - SAFETY PRECAUTIONS

1.1 It is assumed by CENTURY WRECKER CORPORATION that the owner/operator of this equipment has thorough knowledge of the accepted and lawful retrieval and towing methods as dictated by his city, county, or state. CENTURY WRECKER CORPORATION rejects any liability claim that may result from the incorrect or unlawful application of its equipment.

1.2 Improper use of this equipment can be dangerous! Incorrect operation can result in bodily injury to the operator and bystanders. Therefore, a thorough understanding by the operator of the "operating principles" and "operating instructions" as found in this manual is essential.

1.3 Study each job to be done. Apply common-sense judgement to assure safety to yourself and bystanders.

1.4 Read and understand the following charts and labels.

## CERTIFICATION LABEL

Federal law requires that the final stage manufacturer, i.e. that person or company installing equipment on a new chassis, must certify the completed vehicle by obtaining, completing and affixing to the door post on the driver's side of the vehicle, a Certification Label similar to the one shown. (FIG. 1-1)

MANUFACTURED BY \_\_\_\_\_

DATE OF MANUFACTURE \_\_\_\_\_ mo. \_\_\_\_\_ yr.

INCOMPLETE VEHICLE MANUFACTURED BY \_\_\_\_\_

DATE INC. VEH. MFD \_\_\_\_\_ mo. \_\_\_\_\_ yr.

GVWR \_\_\_\_\_

GAWR FRONT \_\_\_\_\_ with \_\_\_\_\_ tires

\_\_\_\_\_ rims @ \_\_\_\_\_ psi cold \_\_\_\_\_

GAWR INTERMEDIATE (1) \_\_\_\_\_ with \_\_\_\_\_ tires

\_\_\_\_\_ rims @ \_\_\_\_\_ psi cold \_\_\_\_\_

GAWR INTERMEDIATE (2) \_\_\_\_\_ with \_\_\_\_\_ tires

\_\_\_\_\_ rims @ \_\_\_\_\_ psi cold \_\_\_\_\_

GAWR REAR \_\_\_\_\_ with \_\_\_\_\_ tires

\_\_\_\_\_ rims @ \_\_\_\_\_ psi cold \_\_\_\_\_

(1) CONFORMITY OF THE CHASSIS-CAB TO FEDERAL MOTOR VEHICLE SAFETY STANDARD NOS \_\_\_\_\_

HAS NOT BEEN AFFECTED BY FINAL STAGE MANUFACTURE

(2) WITH RESPECT TO STANDARD NOS \_\_\_\_\_

THE VEHICLE HAS BEEN COMPLETED IN ACCORDANCE WITH THE CHASSIS CAB MANUFACTURER'S INSTRUCTIONS

(3) THIS VEHICLE CONFORMS TO ALL APPLICABLE FEDERAL MOTOR VEHICLE SAFETY STANDARDS IN EFFECT IN \_\_\_\_\_ MO. \_\_\_\_\_ YR.

VEHICLE IDENTIFICATION NUMBER \_\_\_\_\_

VEHICLE TYPE \_\_\_\_\_

FIG. 1-1

## SPECIFICATION LABEL

Each CENTURY Wrecker will have a specification label mounted on the driver's side of the wrecker frame. The specification label will exhibit the model number and ratings of the wrecker to which it is affixed. (FIG. 1-2)

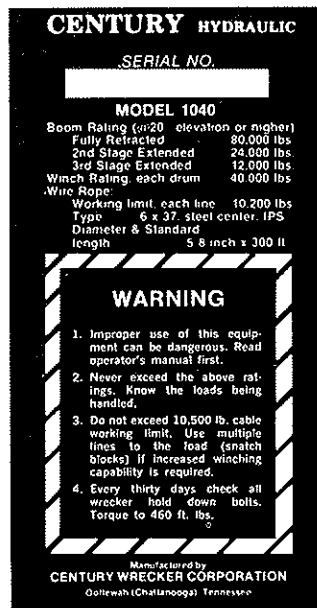

FIG. 1-2

## SPECIFICATIONS

### MODEL 1040

40 ton full hydraulic wrecker with dual 40,000 lb. hydraulic winches, full-power three-stage boom. 94" wide, heavy-duty body with four tool compartments and hydraulic rear outriggers.

### WINCHES

Rating (first layer, each drum) ..... 40,000 lb. each

### CABLE

Diameter and length (each drum) ..... 5/8" dia. x 300 ft.  
Type ..... 6 x 37 steel center IPS  
Working limit (each line) ..... 10,200 lb.

### BOOM

	Length From Pivot	Maximum Working Height (1)	Maximum Working Distance (2)	Boom Rating Static (2)
First Stage	13'	15'	26-1/2"	80,000 lb.
Second Stage	20'	21'	9' 8-1/2"	24,000 lb.
Third Stage	26'	26'	15' 8-1/2"	12,000 lb.

- (1) At maximum boom elevation of 60° above horizontal.
- (2) At minimum boom elevation of 0° above horizontal.

### WEIGHT

Approximate weight 12,500 lb.

### CHASSIS RECOMMENDATIONS

A tandem axle chassis is recommended. However, a single axle chassis may be satisfactory if properly equipped. Consult factory for further information.

Minimum GVWR (Gross Vehicle Weight Rating) 40,000 lb.

Minimum RBM\* each frame rail 3,000,000 in./lb.

Minimum C.B. (Cab to Bogie) Dimension 120".

Minimum frame length behind center line of bogie 62"

The outside frame rails of chassis extending behind cab must be free of fuel tanks, air tanks, battery boxes exhaust stacks, etc.

### STANDARD EQUIPMENT - MODEL 1040

Twin hydraulic pumps • Dual variable speed hydraulic winches • 300 ft. of cable each drum • 360° directional boom sheave system • Power boom elevation • Dual side-by-side elevation cylinders with counter balance valve • Roller bearings for second and third stage extension • Lubrication fittings on all shafts and other moving parts • 94" wide heavy duty body with flat floor • 9" sill channels • Diagonally opposed hydraulic rear outriggers with counter balance valves • Rear tie-back loops and trailer ball bracket • Chain slots for scotch blocks in tailgate • Dual control stations recessed in side • Vernier throttle control • Four 11 cu. ft. tool compartments with shelves and stainless steel key-locking latches • Mud flaps • Federal standard #108 lighting • Deluxe switch panel • Wiring harness • Fold-away tow hitch brackets

\* The RBM is determined by multiplying the section modulus of the frame rail by the tensile strength of the frame material. All frame reinforcements must extend the full length of frame due to body mounted rear jacks.

# Section II - OPERATIONAL FUNCTIONS

2.1 Your new CENTURY Wrecker is totally hydraulic. It receives its power from the truck engine by means of a Power Take-Off/Pump Combination attached to the truck transmission. Since the pump is attached directly to the P.T.O., no drive line or universal joints are needed. (FIG. 2.1)

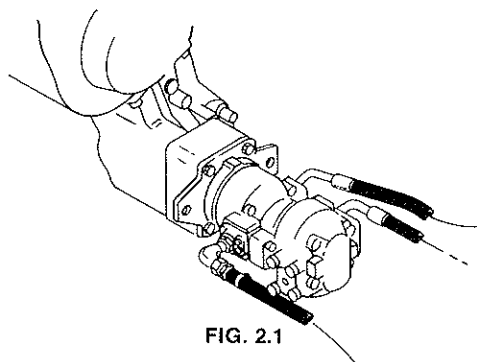

FIG. 2.1

2.2 Each function of your CENTURY Wrecker can be controlled from either of the dual control stations located at the rear of the wrecker. (FIG. 2.2)

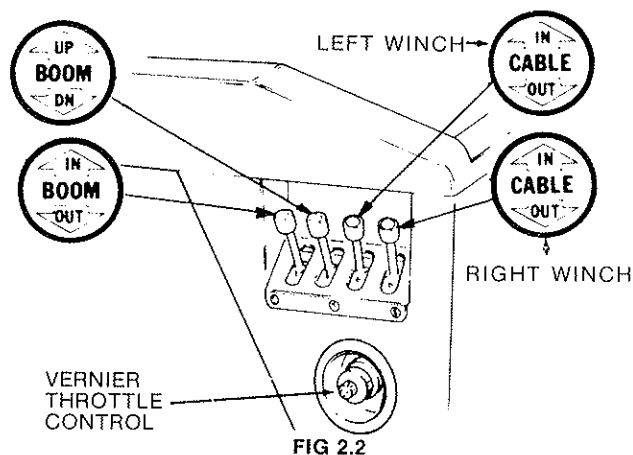

FIG. 2.2

2.3 The vernier throttle control located at the left rear control station is used to vary the speed of the truck engine to govern the maximum speed of the winches and cylinders. (FIG. 2.2)

2.4 The control handles are clearly identified as to functions and directions. Movement of the control handles meters the flow of oil through valves to control the speed of each function.

2.5 The boom is elevated or extended by means of double-acting hydraulic cylinders and can be operated under either "LOAD" or "NO LOAD" conditions.

2.6 The jacks are lowered or raised by activating control handles located at the forward control stations on either side of the wrecker body. (FIG. 2.3)

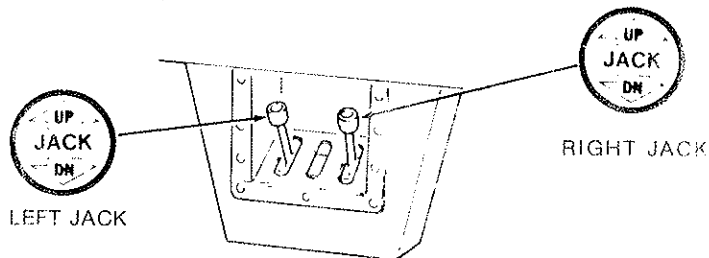

FIG. 2.3

2.7 The self-locking, worm-driven winches are powered by hydraulic motors attached directly to the winch input shafts. (FIG. 2.4)

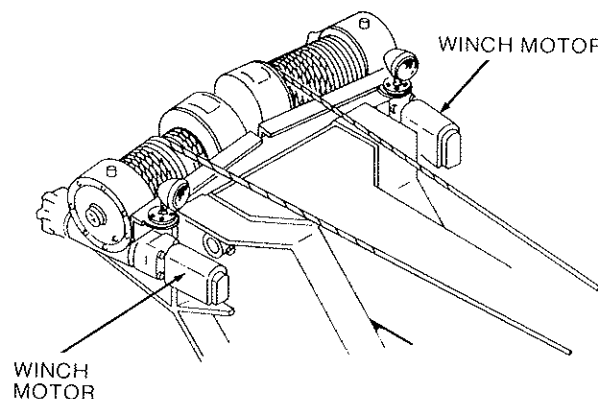

FIG. 2.4

2.8 Before operating your CENTURY Wrecker, remove shipping plugs from the vent caps of each winch. (FIG. 2.5)

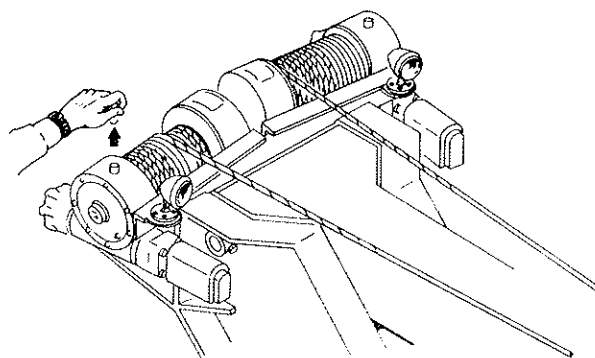

FIG. 2.5

2.9 The CENTURY switch panel controls the flashing beacon bar, flood lights, and hook-up lights. Also mounted in the switch panel is the P.T.O. control knob and indicator lights for each function. (FIG. 2.6)

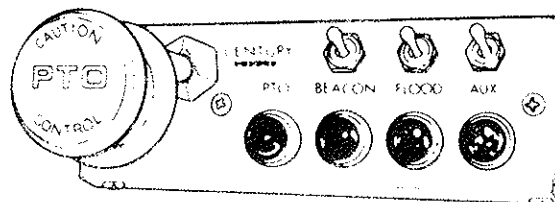

FIG. 2.6

# Section III - OPERATING INSTRUCTIONS

3.1 Reduce engine to idle, depress truck clutch and engage P.T.O. by pulling out knob located on CENTURY switch panel. (FIG. 3.1)

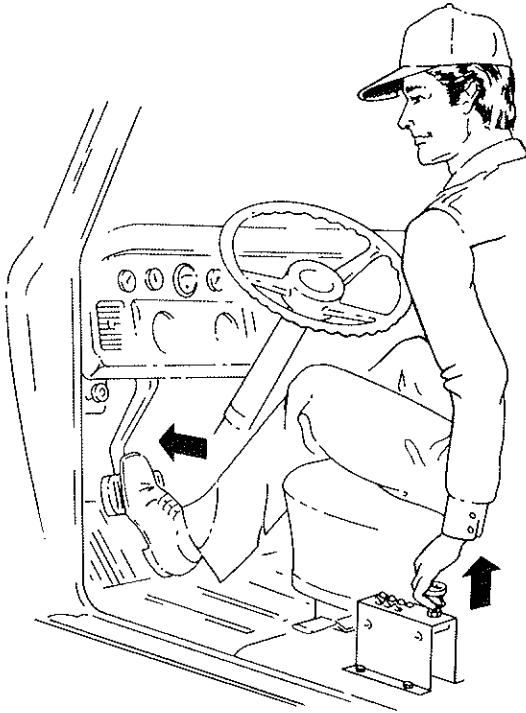

FIG. 3.1  
**Caution!**

Never drive truck on street with P.T.O. engaged as this can cause pump failure from over-speed and over-heating.

3.2 Set engine speed by slowly turning throttle control knob, located below left rear control station, counter-clockwise. A speed range of 1500 RPM is usually sufficient for most applications, but do not exceed 2,000 RPM. To release throttle control, push button in center of knob in, while also pushing knob straight in.

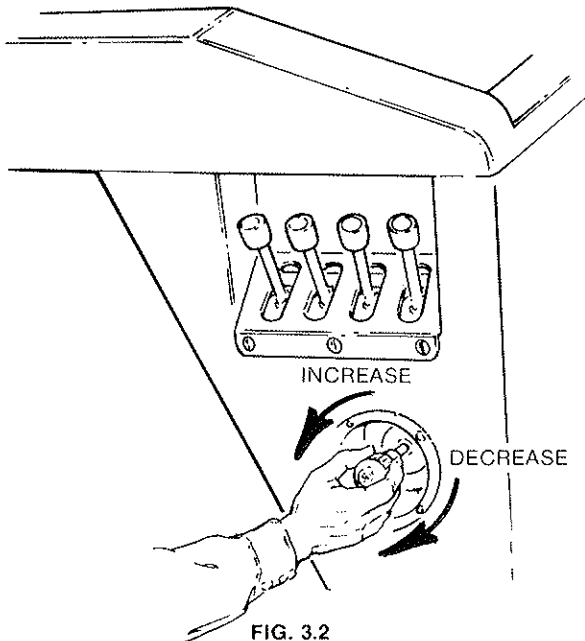

FIG. 3.2

3.3 Before operating any control handles, observe the winch cables to make sure they are free and have sufficient slack to let boom extend. If not, pay out sufficient cable by operating cable "IN-OUT" controls. Keep hand tension on cables to avoid loose cable on drum.

## 3.4 Hydraulic Boom Elevation and Extension

(a) Set boom at desired elevation by operating BOOM "UP-DOWN" control. Boom will be automatically held in this position, even with a loss of hydraulic pressure, by means of a holding valve mounted at the base of the lift cylinders. (FIG. 3.3)

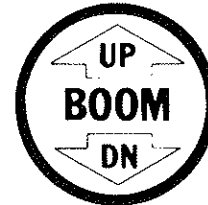

FIG. 3.3

(b) Extend boom to desired distance by operating BOOM "IN-OUT" control. (Caution should still be observed to pay out enough cable to allow boom to extend.) (FIG. 3.4)

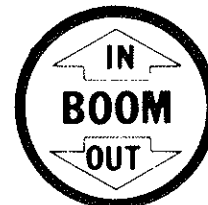

FIG. 3.4

## 3.5 Use of Rear Jacks

(a) The rear jacks are for use when lifting heavy loads.

(b) To raise or lower jacks, operate control handles located on either side of wrecker body at the forward control stations.

# Section IV - MAINTENANCE

4.1 The continued operation of your CENTURY Hydraulic Wrecker is largely dependent upon adherence to a properly scheduled maintenance program. To help you in this program, the CENTURY WRECKER CORPORATION has provided the following information regarding lubrication, preventive maintenance and hydraulic system care.

## 4.2 Hydraulic System

The importance of absolute cleanliness of the hydraulic system cannot be overstressed. The smallest amount of grit, metal flake, or other foreign material in the system can cause extensive damage to pumps, motors, and valves. CENTURY WRECKER CORPORATION has taken every precaution to assure that each component and fitting was thoroughly cleaned and the system purged before your CENTURY Wrecker was put into operation. Therefore, servicing of the system should be done with extreme care.

(a) Before checking oil in reservoir, wipe away all dirt and grime around filler cap before removing cap. When adding oil, make sure containers, funnels, and pouring spouts are absolutely clean.

(b) When replacing hoses, fittings, or other components, clean thoroughly then assemble carefully.

(c) Failure to observe these precautions, and failure to change the filter element at regular intervals could result in loss of your warranty in the event of failure to certain components.

4.3 The following general lubrication and preventive maintenance should be performed at least once per month for moderate usage, or more often as required, for heavy usage:

(a) Inspect, repair, or replace any worn, cracked, leaking, or otherwise damaged components including, but not limited to, the following:

1. Hydraulic hoses and fittings\*
2. Cables and fittings
3. Sheaves
4. Boom-end fittings
5. Controls
6. Hydraulic oil filter
7. Oil reservoir
8. Lights and wiring
9. Winches
10. Pivot bearing surfaces and pins  
(See Lubrication Chart, Page 5)

(b) Check hydraulic oil level in reservoir and fill to within 1-1/2" to 2" from top of tank, or until visible in filler neck. Use SAE 10W/30, multigrade service classification SC (formerly MS) or better.

(c) Replace hydraulic filter element after first week of operation, then every three months thereafter.

(d) Tighten all bolts. Vibration and stress may loosen even properly torqued bolts.

(e) Lubricate all grease fittings on the wrecker including:

1. Jack leg cylinder pivots
2. Sheaves (fittings in sheave shaft)
3. Boom-end swivels (fitting top side of boom swivel)
4. Winch clutches - (See page 21)
5. Boom elevation and extension cylinder pivots
6. Boom pivot

(f) Oil all bearing surfaces which are not equipped with grease fittings. Use pump-can with SAE 30 oil.

(g) Grease boom slide pads with grease fittings located on top of outer boom at heel end - 2nd stage only.

(h) Check oil level in winches. Fill to level of oil plug located in side-plate of gear housing. Use SAE 140 general purpose gear oil. Lubricate grease fittings on clutches - may be reached through plastic cap openings with winch engaged. (See page 21)

(i) Lubricate cables with oily rag while respooling cable onto drum. Special cable lubricants are also available which have penetrating qualities.

4.4 Check torque on wrecker hold-down bolts every month. (Torque to 460 ft. lbs.)

## 4.5 Summary of Required Lubricants

(a) Hydraulic Oil - 10W/30, Multigrade SAE service classification SC (formerly MS) or better.

Examples:

1. Mobil - Deluxe Special 10W30
2. Sinclair - Triplex
3. Texaco - Ursatex 10W/30
4. Amoco - Super Permalube 10W30
5. Gulf - Guflube X.H.D. 10W/30

(b) Worm Gear Oil - SAE 140 general purpose gear oil

Examples:

1. Humbel - Pen-O-Led EP #5
2. Phillips - Phillips Worm Gear oil 140
3. Shell - Macona #978
4. Sinclair - Pennant EP #6
5. Standard - Stanogear #5
6. Texaco - Maropa #5

(c) Grease - General purpose automotive lubricating grease.

(d) Oil for miscellaneous bearing surfaces - SAE 30

(e) Oil for cables - Motor oil or special purpose cable lubricant.

## 4.6 Care and use of hydraulic equipment in areas of extremely cold climate.

When the CENTURY Hydraulic Wrecker is used in seasonal cold climate regions (+ 20° F. and below), the viscosity of the normally recommended 10W/30 engine oil may increase to the point where it adversely affects hydraulic functions during starting and warm-up.

If this is the case, it will be necessary to change fluids seasonally to maintain maximum system efficiency and life. The following list of fluids will, in most cases, prove adequate for this purpose.

Mfg. ....	Prod/Fluid	Mfg. ....	Prod/Fluid
Atlantic Richfield	Duro AW-S-150	Humble	Teresso EP44
Chaplin	Hydro Light	Mobile	DET 24
Chevron	Chevron EP-9	Pure	Puropale AW 150
Cities Service	Pacemaker XD-15	Shell	Tellus 923
Continental	Conoco Super 15	Standard Industroil	FF 44
Gulf	Harmony 43AW	Sun	Sunvis 816 WR
Houghton	Hydro-Drive HP-150	Texaco	Rando HD-150

Regions subject to continuous sub-zero or arctic climates require special hydraulic fluids. Contact CENTURY WRECKER CORPORATION or your local oil supplier for information regarding specific temperature requirements.

\*There is no practical way to determine the life expectancy of rubber hydraulic components such as hoses, o-rings, etc. While appearing to be in top condition these components may be adversely affected by continued usage, climate or the passing of time. For this reason, it is recommended that the rubber components (especially hoses) should be replaced every 5 years.

# SECTION IV - MAINTENANCE

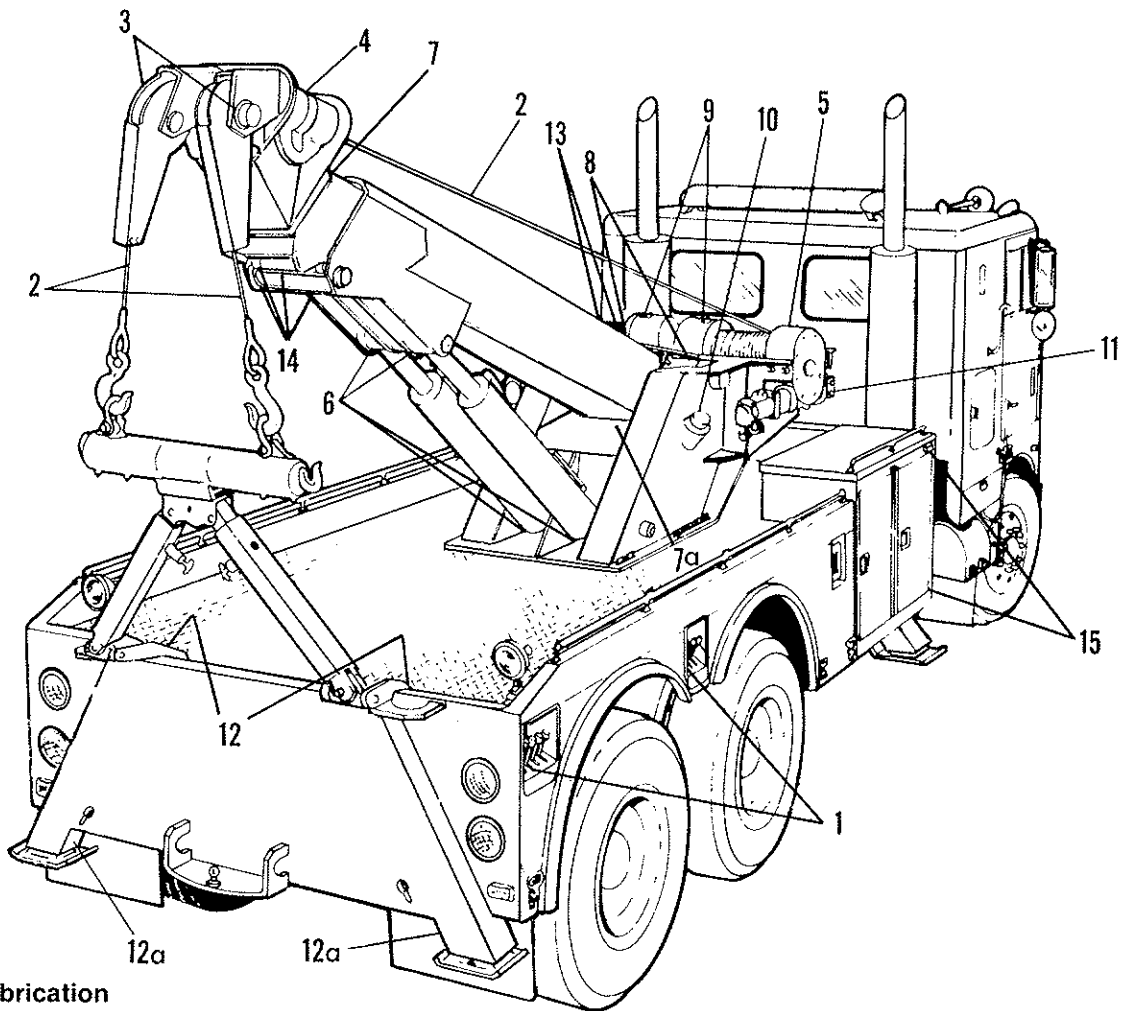

## Lubrication

1. Bell crank and control handle shafts - (Grease with GP grease) (See pg. 25, 26, 27)
2. Cables - (Lubricate with oily rag or approved cable lubricant)
3. Sheaves - (Grease with GP grease)
4. Boom-end swivels - (Grease with GP grease)
5. Winch oil level - (Fill to level of oil plug in side of gear housing. SAE 140 general purpose gear oil)
6. Cylinder pivot bearings (lift) - (Grease with GP grease)
7. Cylinder pivot bearing - (ext.) (Grease with GP grease) - extend 3rd stage boom out approximately 2 ft. and grease from top of boom.
- 7a. Cylinder pivot bearing - (ext.) (Grease with GP grease) - raise boom to full elevation and grease from inside of wrecker frame.
8. Boom pivot bearings - (Grease with GP grease) (Fittings found in the top side of the boom pivot bearing blocks)
9. Winch clutch - (Grease with GP grease) (See page 4, section h)
10. Oil reservoir - (Fill to bottom of filler spout, use SAE 10W/30 - approximately 60 Gals.)
11. Oil filter - (Replace after first week of operation, then every three months thereafter.)
12. Rear jacks - (Grease with GP grease) (Fittings located under floor plate on jack retainer shaft)
- 12a. Rear jacks - lower (Grease with GP grease) (Lower jack approximately 8", fitting located on the inside side of tube)
13. Boom slide pads - (Grease with GP grease) (Fittings on top of outer boom at heel end)
14. Roller blocks - (Grease with GP grease)
15. Toolbox door hinges - top and bottom (Grease with GP grease)

## Important

The above lubrication points should be cared for monthly; more often if the wrecker is used quite frequently.

**Note:** Check wrecker frame hold down bolts every month. (Torque to 460 ft. lbs.)





# SECTION V — INSTALLATION 1040

## P.T.O. & PUMP INSTALLATION

1. Mount Century deluxe switch panel to floor of cab between driver's seat and door (Refer to pg. 3 fig. 3.1 for picture). Use two switch panel mounting brackets (P/N 0700952) with hardware from "Switch Panel Mtg. Hardware Kit" #0900217.
2. Install P.T.O. control cable (knob end) to switch panel and guide cable down to transmission. Be sure cable is not pinched or crimped at any point and does not interfere with any components on truck. This end of cable will be attached in later step.
3. Drain truck transmission oil.
4. Disengage P.T.O. (Gears should turn freely.)
5. Check and remember for step #10 which way P.T.O. gear shifter rod has to move to engage P.T.O.
6. Install P.T.O. to transmission of truck using enclosed gaskets and stud kit. (For proper installation refer to P.T.O. owner's manual supplied with P.T.O. - Ideally P.T.O. should be mounted to transmission, so that pump, when mounted to P.T.O., will be to the rear of cab.)

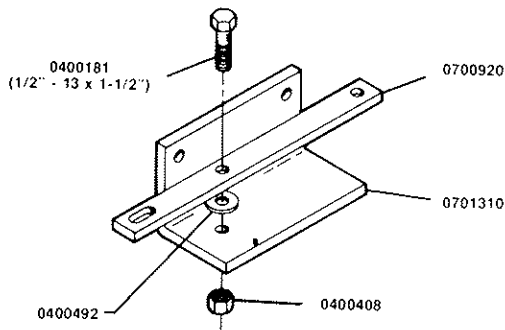

Figure 5.1

7. Assemble "Mechanical Advantage" system according to fig. 5.1. Use hardware from "Manual P.T.O. Control Kit" #0900267.
8. Mount assembled "Mechanical Advantage" system to P.T.O. Use two capscrews from P.T.O. inspection plate to mount angle bracket. Assemble the rest of "Mechanical Advantage" system according to fig. 5.2. Use balance of hardware from "Manual P.T.O. Control Kit" #0900267.
9. Push P.T.O. control cable knob all the way in at switch panel.

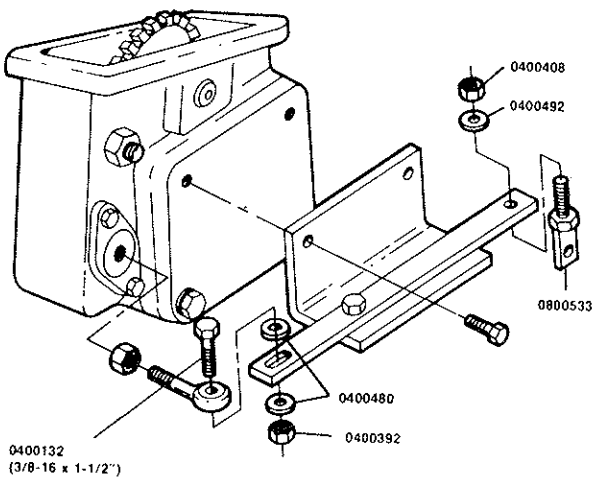

Figure 5.2

10. Be sure that P.T.O. is disengaged, then connect P.T.O. control cable to eye-bolt weldment (0800533) on "Mechanical Advantage" pivot arm, in such a way, so that when P.T.O. control cable knob is pulled, pivot arm will engage P.T.O. gears (fig.5.3). Use two 5/16 helical lockwashers and one 5/16-24 hex nut supplied in "P.T.O. Control Cable Kit" #0900454.

11. Assemble pump. Use fittings from "Pump Hydraulic Kit" #0900385. Refer to "Pump & Filter Hydraulics" page 19 for diagram of correct installation.

12. Mount pump to P.T.O. in a position to allow fittings on pump to be horizontal (parallel with ground). Hardware supplied with P.T.O.

**Note:**

Be sure to refill oil in transmission before operating.

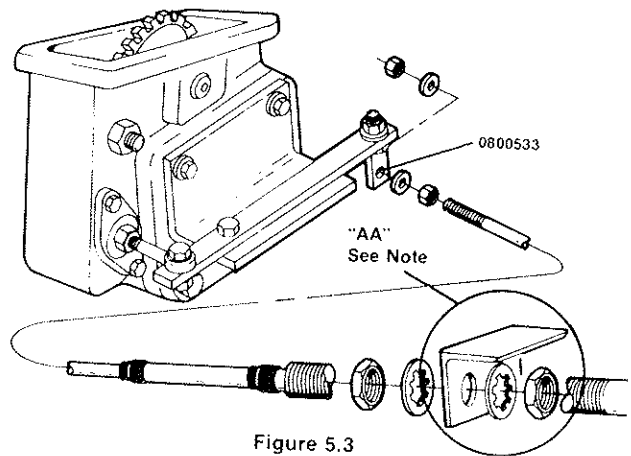

Figure 5.3

**Note:**

Customer **MUST** supply own mounting bracket at area "AA" to hold control cable stationary. Mount bracket to truck chassis or anything on truck chassis that is stationary. Be sure bracket does not interfere with movement or function of any component on truck

## PREPARATION OF TRUCK FRAME

1. Cut truck frame rails off at 62-1/2" behind center line of bogie. (Fig. 5.4)

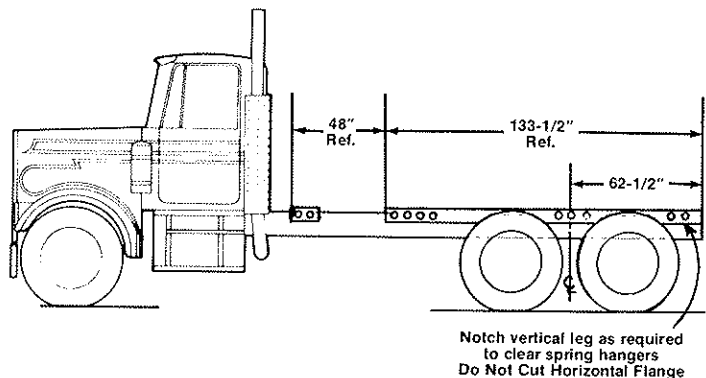

Notch vertical leg as required to clear spring hangers  
Do Not Cut Horizontal Flange

Figure 5.4

2. If any crossmembers are in the cut-off portion of the frame, they **MUST** be removed and reinstalled on the frame before the wrecker body is installed. Failure to replace crossmember may void your frame warranty.



# SECTION V — INSTALLATION 1040

3. Place 4" x 4" x 1/2" body mounting angles on truck frame using dimensions shown in Fig. 5.4. Leg with pre-drilled holes to be vertical against side of frame. Notch vertical leg of angles as necessary to clear spring hangers and other obstructions. If a pre-drilled hole is notched out, redrill the hole as close to original position as possible. DO NOT CUT HORIZONTAL LEG OF MOUNTING ANGLE.

4. After notching to clear obstructions, clamp angles securely to frame. Piloting through pre-drilled holes in angles, drill holes in frame. Bolt angles in place with 7/8" diameter bolts and nuts in "Body Mounting Hardware Kit" #0900236. DO NOT WELD ANGLES TO TRUCK FRAME.

## MODIFICATION OF TRUCK FRAME CUT-OFF

1. If 10-1/2" dimension is exceeded from top of mounting angle to bottom of truck frame flange at rear of 62-1/2" cut-off, cut bottom flange of truck frame 10-1/2" down from top of mounting angle and 8" forward from rear of 62-1/2" cut-off. (Fig. 5.5)

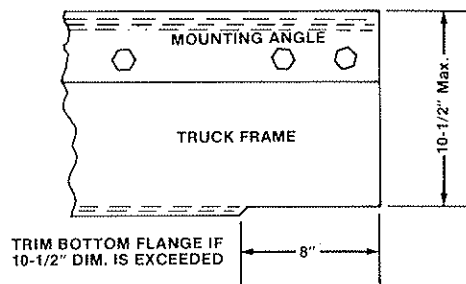

FIG. 5.5

2. Determine "X" dimension on wrecker body furnished. Note: "X" dimension is the distance between bottom of wrecker body sill channel and outrigger reinforcing angle on tailgate. (Fig. 5.6)

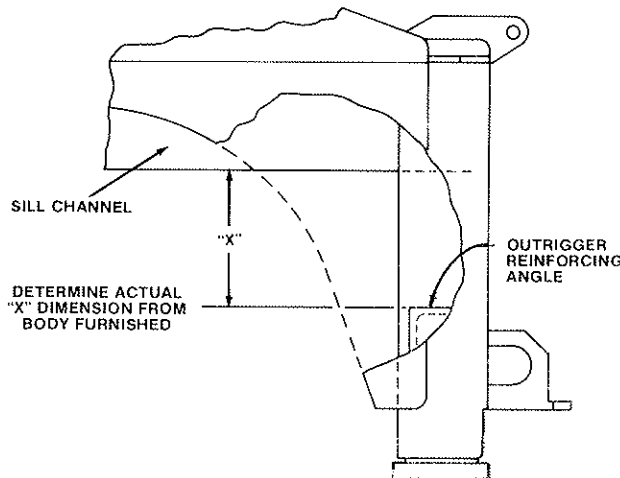

FIG. 5.6

3. Securely clamp one tailgate support angle (6" x 4" x 1/2") on the outside of each truck frame rail so that the horizontal leg of each angle is at "X" dimension from top of body mounting angle (Fig. 5.7)

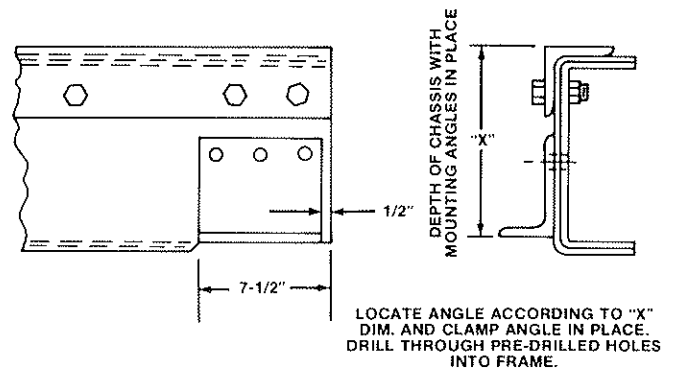

FIG. 5.7

4. Drill holes through truck frame piloting through pre-drilled holes in support angle.

5. Mount support angles to truck frame using 7/8" bolts and nuts supplied in "Body Mounting Hardware Kit" #0900236. DO NOT WELD SUPPORT ANGLES TO TRUCK FRAME.

6. Before attempting to install the Century Wrecker Body Assembly, it may be necessary to rework the chassis exhaust (tailpipe) to prevent its interference with the wrecker body.

7. Install electrical wiring harness in wrecker body using "Wiring Harness Hardware Kit" #0900287. Refer to page 24 for illustration.

8. Install light kit in wrecker body. See page 23.

## INSTALLATION OF WRECKER BODY, FRAME AND BOOM

**NOTE:** The outside tires may have to be removed before installing wrecker body.

1. Locate and identify on truck cab wiring harness each of the following wires.

- Running lights
- Back-up lights
- Right turn & stop light
- Left turn & stop light

Cut each of these wires about 12" behind truck cab. (Wires will be connected to wrecker body in a succeeding step.)

2. Using hoist, overhead crane, etc., position and center body on truck frame. (In some cases it may be necessary to lift front of body higher than the rear to get outrigger reinforcing angle on tailgate installed properly.)

3. Weld wrecker body sill channels to body mounting angle on truck frame. DO NOT WELD TO TRUCK FRAME. Welds should be 5 - 6 inches long every 8 - 9 inches apart except in areas where bolts are closer together, welds should be continuous in these areas.

4. Weld support angles to outrigger reinforcing angle on tailgate.

5. Complete wiring hook-ups between cab and wrecker body. See page 22 for color coding of wiring harness. If any wires for optional accessories are not used, tape end of wire and store out of the way.

6. To finish wiring hook-ups to switch panel, connect 4-wire wiring harness extension, (see page 22) to the matching color wire on wrecker body wiring harness, run these 4 wires up to switch panel. Splice green (P.T.O.) wire lead into wire on switch panel that runs

# SECTION V — INSTALLATION 1040

from red P.T.O. light to white plunger button. Connect white (auxiliary) wire lead to toggle switch marked "Aux". Connect brown (floodlights) wire lead to toggle switch marked "Flood". Switch Panel has wire with one loose end, this is a ground wire and must be grounded. Run a "hot" wire (not supplied) from truck cab wiring harness to switch panel and connect to post with end painted red. Purple wire (toolbox lights) lead from wrecker body wiring harness may also be connected to this red post.

**Note:**

Toggle switch marked "Beacon" is for optional Flashing Beacon Light. No wire is included on harness - customer must supply own wire if option is used.

7. Install suction line fittings to bottom of oil reservoir in wrecker frame weldment using "Suction Line Fittings Kit" #0900386. See page 19 for diagram of installation. Be sure fittings are tight to eliminate oil leakage.

8. Mount wrecker frame assembly to wrecker body using 7/8" dia. bolts & nuts from "Wrecker Frame Mounting Hardware Kit" #0900234. Bolts should come from underneath floor plate with nuts on top. Torque nuts to 460 ft. lbs.

9. Install suction hose (2" ID x 10') from pump to oil reservoir in bottom of wrecker frame. Use two hose clamps supplied with "Hose Clamps Hardware Kit" #0900235. See Pump & Filter Hydraulics, page 19, for location of suction line hose to pump.

10. Make two high pressure hose assemblies by connecting 1" I.D. x 48" long hoses to 1" I.D. x 66" long hoses with straight couplings (P/N 0300431 - 1" JIC Male x 1" JIC Male).

11. Install high pressure hose assemblies from pump to control valves. See "Pump & Filter" Hydraulics" page 19 for diagram.

12. Install two filter return line hoses (1" ID x 18" lg.) from filters to control valves. Use 4 hose clamps from "Hose Clamps Hardware Kit" #0900235. See "Pump & Filter Hydraulics" page 19 for diagram.

13. Install two lower elevation cylinder hoses to fittings on elevation cylinders. (See "Elevation Cylinder Hydraulics" page 14 for diagram) Route hoses down through holes in wrecker frame base plate and under floor plate forward to control valves. Do not install to control valves at this time.

14. Install boom in wrecker frame by first inserting two extension cylinder hoses through hole in front plate of wrecker frame, then align 3" boom pivot shaft holes in boom with shaft holes in wrecker frame. Slide pivot shaft through wrecker frame and boom. Secure shaft by installing part #0400180 - (1/2" - 13 x 6" cap screw) through hole in pivot shaft boss on wrecker frame and hole in pivot shaft. Tighten cap screw with part #0400407 (1/2" x 13 Nylok nut)

15. Place upper rod ends of elevation cylinders in brackets on bottom of boom. Install two pivot shafts (2" dia. x 8" lg.) through brackets and rods. Secure in place with part #0400130 (3/8" - 16 x 3-1/2" cap screw) and 0400392 (3/8" - 16 Nylok nut). Refer to "Wrecker & Boom Ass'y" pages 11 and 12.

16. To complete Winch Motor, Elevation Cylinder and Extension Cylinder hose hook-ups to control valves, refer to page 13 for correct hose location on correct control valve. Rear outrigger hoses are already connected by factory.

**Note:**

If any hydraulic function works in reverse, according to control handles, reverse hose hook-ups on control valve ports.

17. Install two control valve access cover plates to wrecker body using "Access Cover Mounting Kit" #0900266. See page 10.

18. Fill oil reservoir in wrecker frame with recommended oil for your areas. (See pg. 4, Type S.C. or better.)

**Note:**

When filling oil reservoir be sure to clean filler neck on frame of all dirt and grease. Reservoir will be full when oil can be seen at bottom of filler neck. Do not fill beyond this point as approximately 1" of air space is required in reservoir.

19. Mount rear mud guards to wrecker body using "Mud Guard Mtg. Hardware Kit" #0900408. See page 10.

20. Mount mud flaps to rear mud guards using "Mud Flap Mtg. Hardware Kit" #0900451. See page 10.

21. Install Boom End Swivels using hardware from "Boom Swivel Installation Kit" #0900279. See page 12.

22. Guide end of wire rope through boom end swivel and install on winches.



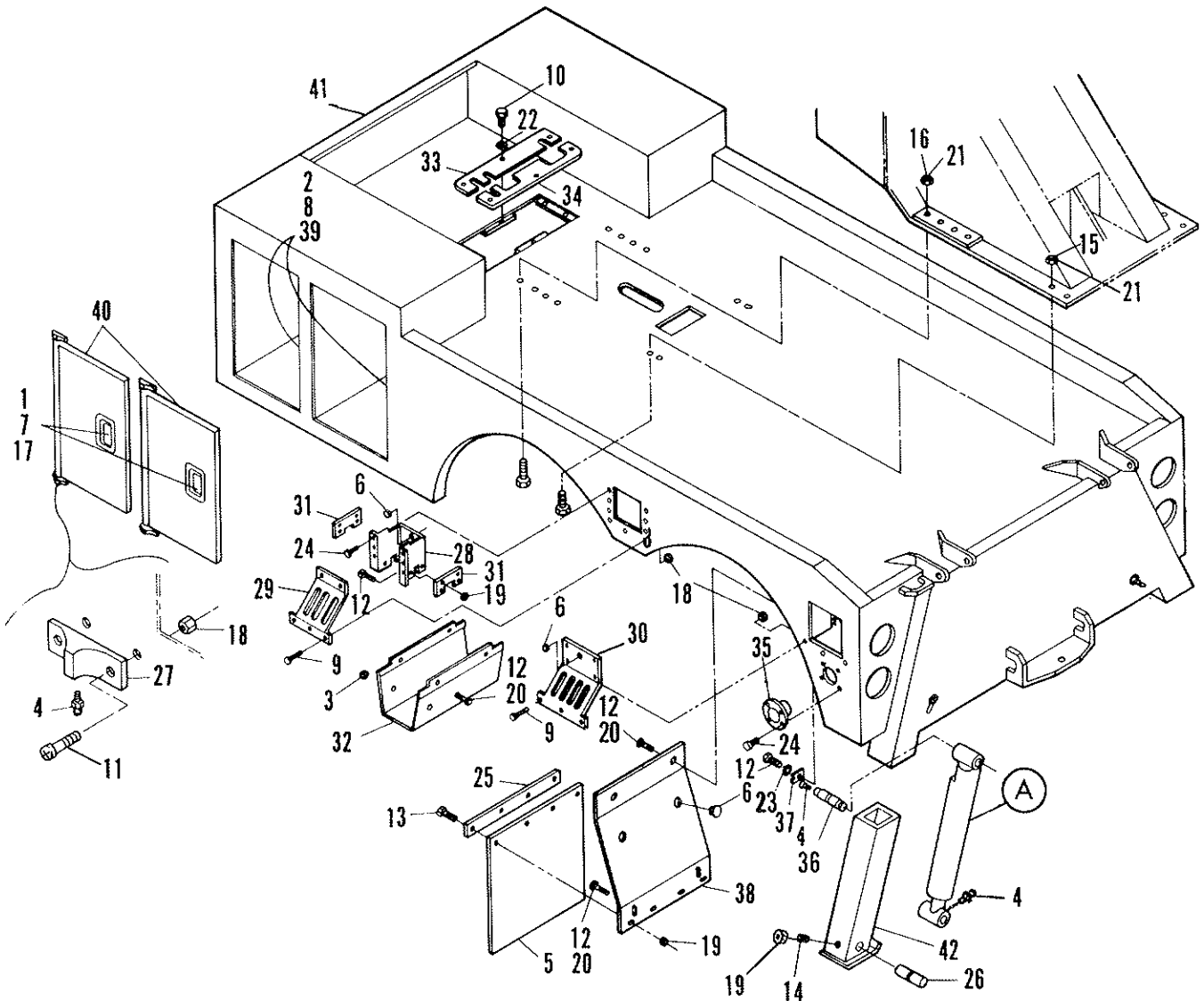

## I040 BODY ASSEMBLY

ITEM	PART NO.	DESCRIPTION	NO.REQ'D	ITEM	PART NO.	DESCRIPTION	NO. REQ'D
1	0300027	Tool Compartment Latch	4	22	0400452	1/4" Helical Lockwasher, Pl.	6
2	0300028	Tool Compartment Striker	4	23	0400482	3/8" Helical Lockwasher, Pl.	2
3	0300032	1" Dia. Hole Plug	6	24	0400567	1/4" Steel Rivet, Pl.	16
4	0300113	Grease Fitting - Straight	12	25	0700554	Bar, Mud Flap Mtg.	2
5	0300140	Mud Flap	2	26	0700884	Shaft, Jack, Lower	2
6	0300868	1-1/4" Dia. Hole Plug	6	27	0700963	Pivot Block, Tool Compt. Hinge	8
7	0400021	Mach. Screw #8 - 32 x 1/2" Rd. Hd. Phillips, St. Stl.	16	28	0701018	Body, Control Panel	2
8	0400045	Screw, #10 - 32 x 1/2" Phillips, Self Tapping Rd. Hd. St. Stl.	8	29	0701019	Cover, Control Panel - Front	2
9	0400061	Mach. Screw 1/4" - 20 x 3/4" Pan Hd. Slotted, Pl.	24	30	0701020	Cover, Control Panel - Rear	2
10	0400066	Cap Screw 1/4" - 20 x 3/4" Hex Hd. Gr. 5 Pl.	6	31	0701138	Extension Plate, Control Station	4
11	0400071	Mach. Screw 1/4" - 20 x 3/4" Rd. Hd. Phillips St. Stl.	16	32	0701193	Mud Guard, Front	2
12	0400121	Cap Screw 3/8" - 16 x 3/4" Hex Hd. Gr. 5 Pl.	26	33	0701243	Pl. Access Cover - Front	1
13	0400122	Cap Screw 3/8" - 16 x 1-1/4" Hex Hd. Gr. 5 Pl.	8	34	0701244	Pl. Access Cover - Rear	1
14	0400139	Set Screw 3/8" - 16 x 1-1/2", Socket Hex	2	35	0701328	Throttle Control Housing	1
15	0400306	Cap Screw 7/8" - 9 x 3" Hex Hd. Gr. 8 Pl.	4	36	0701384	Shaft, Jack - Upper	2
16	0400307	Cap Screw 7/8" - 9 x 4" Hex Hd. Gr. 8 Pl.	8	37	0701385	Retainer, Upper Jack Shaft	2
17	0400351	Keps Nut #8 - 32, Pl.	16	38	0701633	Mud Guard, Rear	2
18	0400367	1/4" - 20 Hex Nut, Nylok, Pl.	40	39	0701675	Spacer, Striker	3
19	0400392	3/8" - 16 Hex Nut, Nylok, Pl.	18	40	0800215	Tool Compt. Door Weldment	4
20	0400396	3/8" - 16 Tinnerman "J" Nut	16	41	0800356	Body Weldment	1
21	0400437	7/8" - 9 Hex Nut, Nylok, Gr. 8, Pl.	12	42	0800431	Inner Jack Weldment	2
				A	See Page 17		

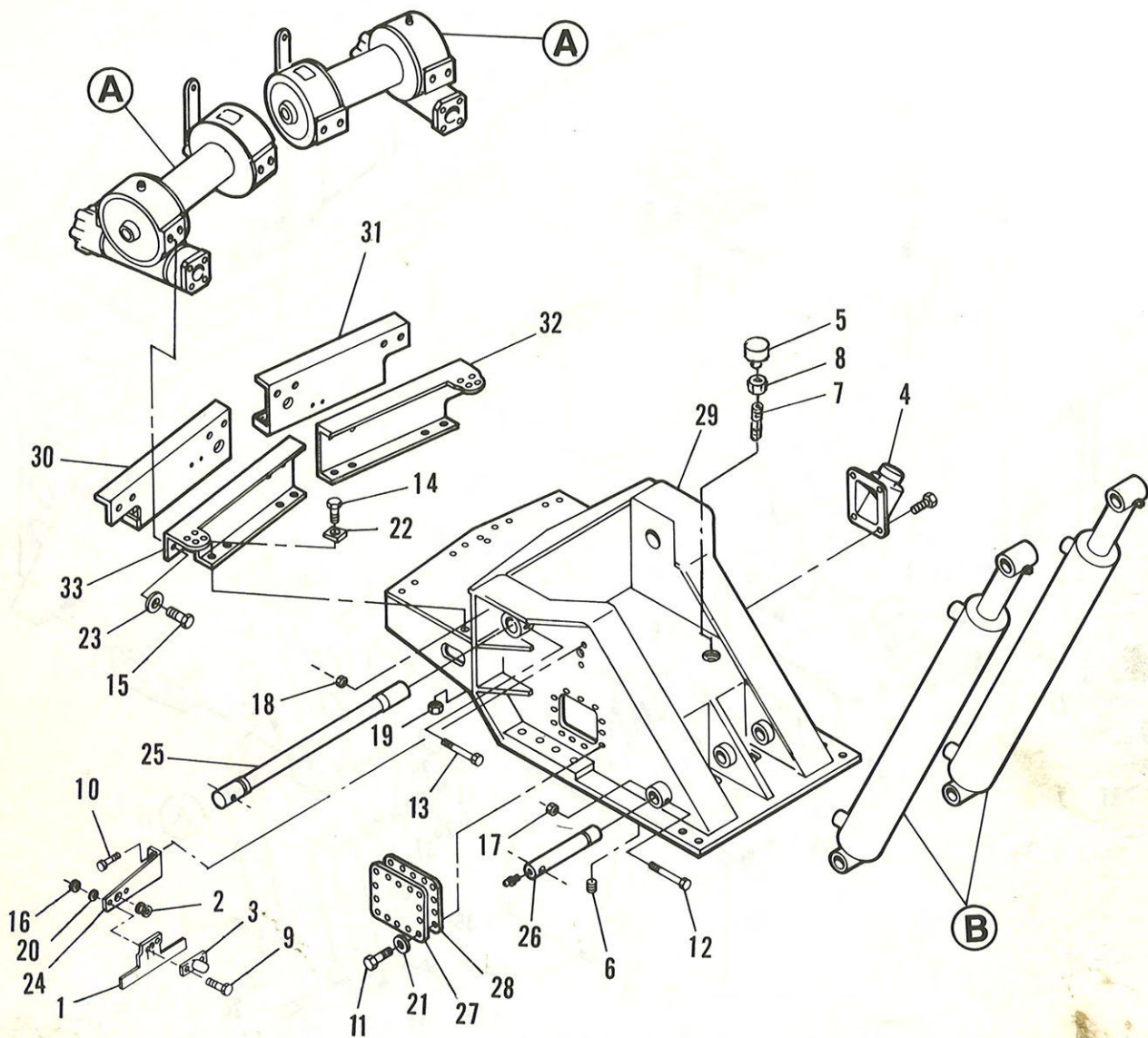

## WRECKER FRAME ASSEMBLY

ITEM	PART NO.	DESCRIPTION	NO. REQ'D	ITEM	PART NO.	DESCRIPTION	NO. REQ'D
1	0300076	Holder - License Plate	1	18	0400407	Nut - 1/2" - 13 Nylok Hex	1
2	0300117	Grommet, Rubber	2	19	0400436	Nut - 7/8" - 9 Nylok	16
3	0300273	Illuminator, License Plate	1	20	0400452	Lockwasher, Helical 1/4" Pl.	2
4	0300312	Filler - Strainer - Breather	1	21	0400481	Lockwasher - 3/8" Helical - Pl.	12
5	0300629	Breather	1	22	0400514	Washer - 7/8" Square - Beveled	16
6	0301081	Cap Plug	1	23	0400515	Lockwasher - 7/8" Helical - Plated	16
7	0301344	Pipe Nipple - Breather Extension	1	24	0700190	Bracket - License Plate	1
8	0301345	Bushing - Female 1/4" NPT	1	25	0700463	Shaft - Boom	1
9	0400061	Screw, Slotted Pan Hd., 1/4"-20 NC X 3/4" Pl.	2	26	0700464	Shaft - Lower - Elevation Cylinder	2
10	0400062	Machine Screw - 1/4" x 3/4" Thread Cutting Hex	2	27	0700487	Cover - Clean Out	1
11	0400121	Cap Screw - 3/8"-16 x 3/4" Hex Hd. Gr. 5 Pl.	12	28	0701316	Gasket - Clean Out Cover	1
12	0400130	Cap Screw - 3/8"-16 x 3-1/2" Hex Hd. Gr. 5 Pl.	2	29	0800158	Wrecker Frame Weldment	1
13	0400180	Cap Screw - 1/2"-13 x 6" Hex Hd., Gr.5 Pl.	1	30	0800368	Channel - Front - Left Winch	1
14	0400301	Cap Screw - 7/8"-9 x 3" Hex Hd. Gr.5 Pl.	16	31	0800369	Channel - Front - Right Winch	1
15	0400302	Cap Screw - 7/8"-9 x 2" Hex Hd. Gr. 5 Pl.	16	32	0800394	Channel - Rear - Right Winch	1
16	0400366	Nut, 1/4" - 20 NC Pl.	2	33	0800395	Channel - Rear - Left Winch	1
17	0400392	Nut - 3/8" - 16 Nylok	2	A	See Page 21		
				B	See Page 14		



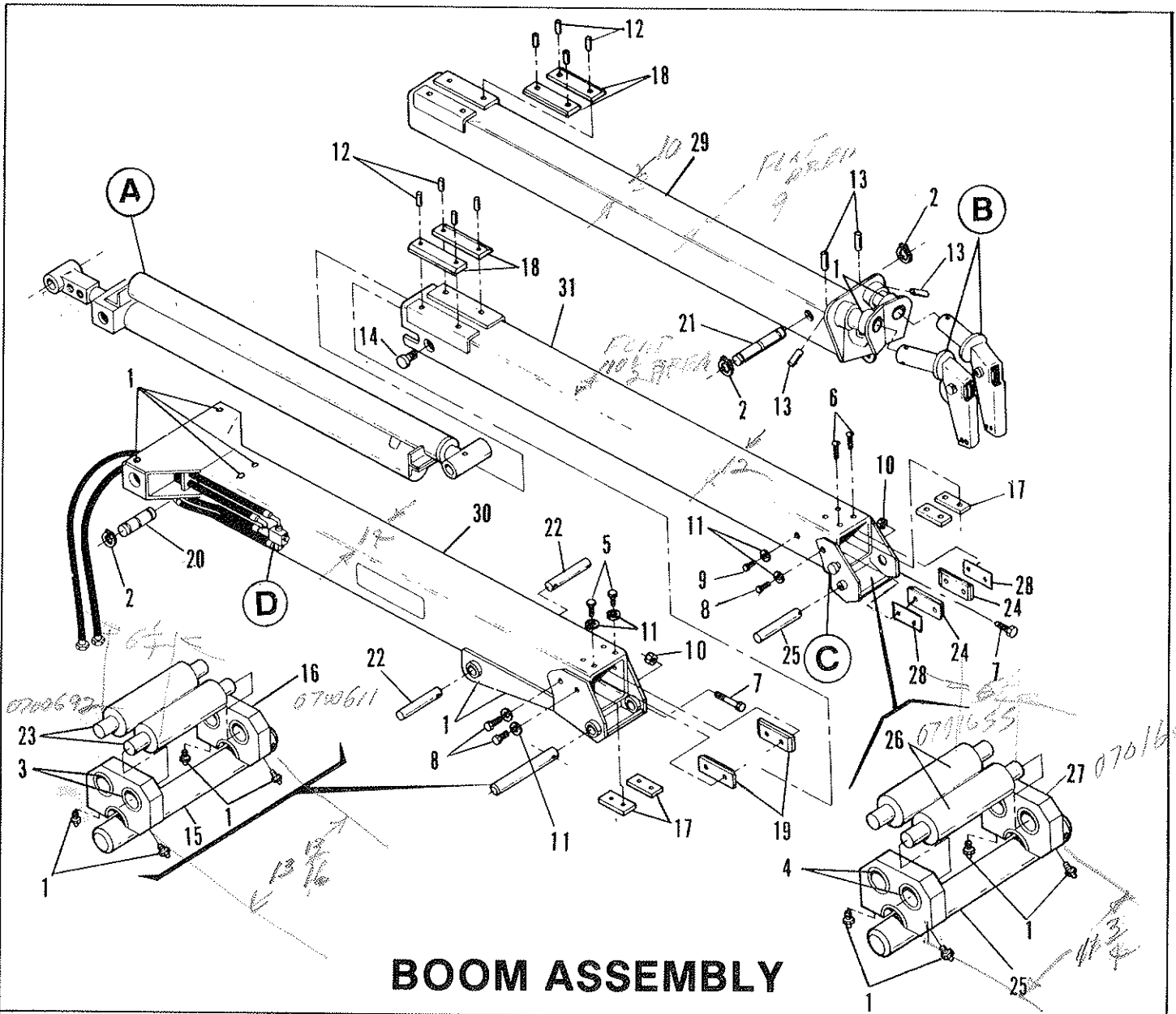

# BOOM ASSEMBLY

ITEM	PART NO.	DESCRIPTION	NO.REQ'D	ITEM	PART NO.	DESCRIPTION	NO.REQ'D
1	0300113	Grease Fitting	16	16	A0700611	Block, Outer Boom Roller Pivot	2
2	0300329	Snap Ring	4	17	0700613	Bar, Boom Top Spacer	4
3	0300738	Bronze Bushing - Oilite	4	18	0700615	Pad. Slide - Nylatron	4
4	0301329	Bronze Bushing - Oilite	4	19	0700625	Pad. Slide, Outer Boom - Side	2
5	0400126	Cap Screw, 3/8" - 16 x 1" Hex Hd. Gr. 5, Pl.	4	20	0700626	Shaft, Extension Cyl.	1
6	0400128	Screw, 3/8" - 16 x 1" Flat Hd. Slotted Gr. 5, Pl.	4	21	0700627	Shaft, Extension Cyl.	1
7	0400130	Cap Screw, 3/8" - 16 x 3 - 1/2" Hex Hd. Gr. 5, Pl.	2	22	0700628	Shaft, Elevation Cyl. Rod	2
8	0400132	Cap Screw, 3/8" - 16 x 1 - 1/2" Hex Hd. Gr. 5	6	23	A0700692	Roller, Outer Boom	2
9	0400141	Cap Screw, 3/8" - 16 x 7/8" Hex Hd. Gr. 5, Pl.	2	24	0700909	Pad. Slide, 2nd Stage	2
10	0400392	Nut, 3/8" - 16 Nylok, Pl.	2	25	A0701654	Shaft, 2nd Stage Boom, Roller Pivot	1
11	0400482	3/8" - Lockwasher, Helical Pl.	12	26	A0701655	Roller, 2nd Stage Boom	2
12	0400554	3/8" x 1" Roll Pin	8	27	0701666	Block, 2nd Stage Boom Roller Pivot	2
13	0400557	1/2" x 1-1/4" Roll Pin	6	28	0701690	Spacer, 2nd Stage	2
14	0700491	Trunnion, Extension Cyl.	2	29	0800200	Boom Weldment - 3rd Stage	1
15	A0700605	Shaft, Outer Boom Roller Pivot	1	30	0800202	Outer Boom Weldment	1
				31	0800537	Boom Weldment - 2nd Stage	1
				A		For Breakdown, See Page 15	
				B		For Breakdown, See Page 20	
				C		For Breakdown, See Page 20	
				D		For Hydraulics, See Page 16	

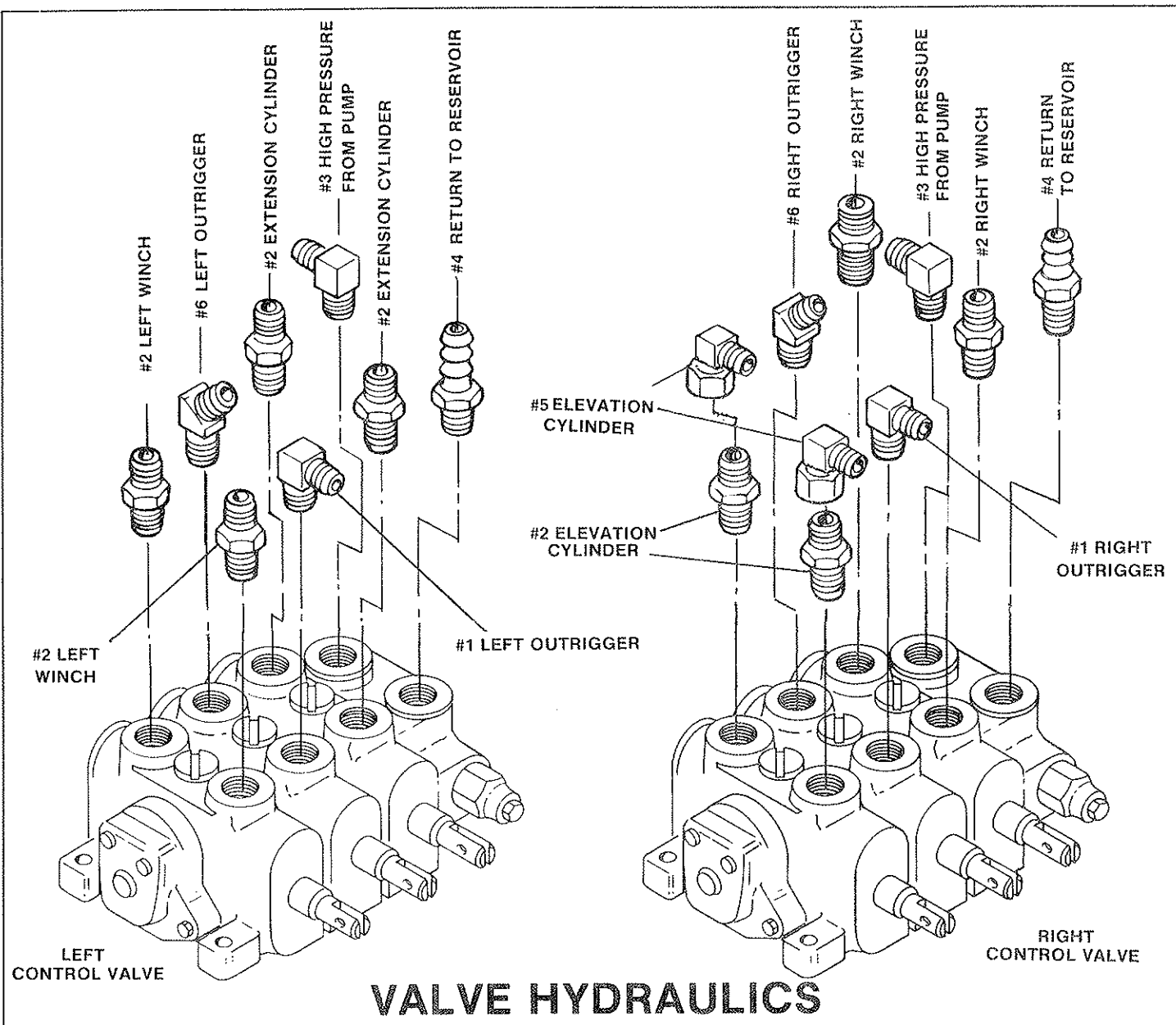

ITEM	PART NO.	DESCRIPTION	NO.REQ'D	ITEM	PART NO.	DESCRIPTION	NO.REQ'D
1	0300052	Elbow 90° - 5/8" SAE "O" Ring x 1/2" JIC	2	4	0300492	Hose Barb - 1" SAE "O" Ring x 1" I.D. Hose	2
2	0300400	Straight Conn. - 3/4" SAE "O" Ring x 3/4" JIC	8	5	0301330	90° Elbow, 3/4" Female JIC Swivel - 3/4" Male JIC	2
3	0300401	Elbow 90° - 1" SAE "O" Ring x 1" JIC	2	6	0301331	45° Elbow, 5/8" SAE - 1/2" JIC	2



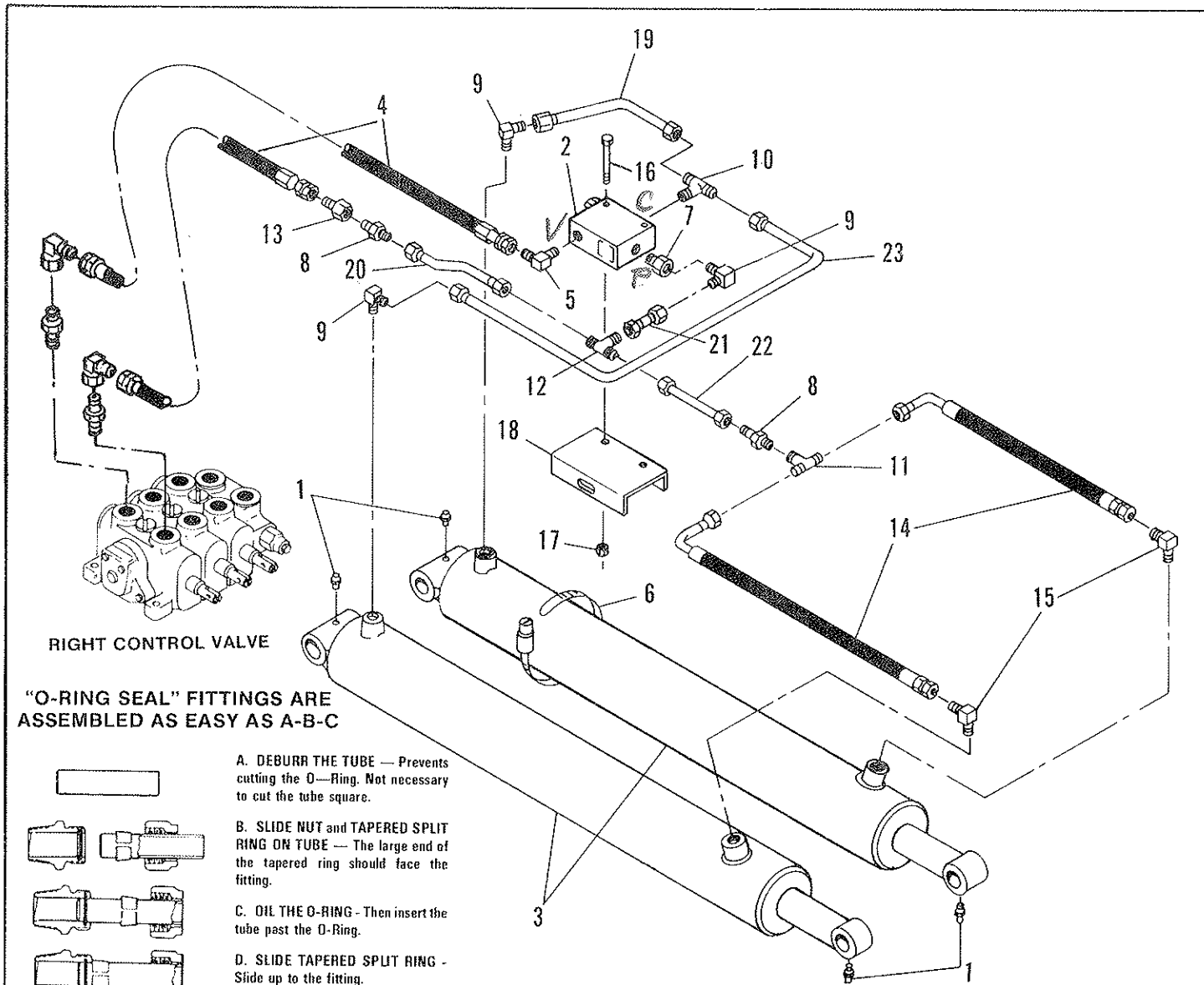

RIGHT CONTROL VALVE

"O-RING SEAL" FITTINGS ARE ASSEMBLED AS EASY AS A-B-C

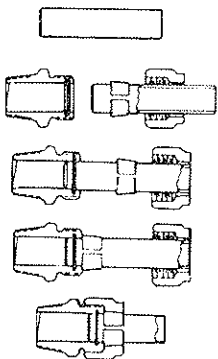

- A. DEBURR THE TUBE — Prevents cutting the O—Ring. Not necessary to cut the tube square.
- B. SLIDE NUT and TAPERED SPLIT RING ON TUBE — The large end of the tapered ring should face the fitting.
- C. OIL THE O-RING - Then insert the tube past the O-Ring.
- D. SLIDE TAPERED SPLIT RING - Slide up to the fitting.
- E. TIGHTEN NUT HAND TIGHT - Then with wrench tighten one turn or until the rear of the tapered ring is flush with the nut.

HOW THE SPLIT RING GRIPS — Note the taper. As nut is tightened the ring is wrapped around the tube, gripping it in like manner to a locking collet in a chuck. This principle grips and locks tighter and stronger as the pressure increases. Note that the nut has nothing to do with the seal ... It is separate!

## ELEVATION CYLINDER HYDRAULICS

ITEM	PART NO.	DESCRIPTION	NO.REQ'D	ITEM	PART NO.	DESCRIPTION	NO.REQ'D
1	0300113	Grease Fitting	4	13	0300829	Straight Connector - 3/4" NPT x 3/4" JIC	1
2	0300310	Holding Valve	1	14	0301098	Hose Elevation Cylinder Upper - 3/4" - 23-1/2" Lg.	2
3	0300438	Hydraulic Lift Cylinders	2	15	<del>0301406</del>	Elbow - 90°, 3/4" JIC x 3/4" NPTF	2
4	0300608	Hose - Elevation Cylinder - Lower	2	16	0400107	Cap Screw - 5/16" - 18 x 2-1/2" Hex Hd., Gr. 5 Pt.	2
5	0300615	Elbow - 90°, 3/4" NPT - 3/4" JIC	1	17	0400381	Nut - 5/16" - 18 Nylok	2
6	0300644	Clamp - Hose 8"	1	18	0700729	Channel - Holding Valve	1
7	0300711	Reducer - 1/4" NPT - Male x 3/4" NPT - Female	1	19	0700730	Tube - 3/4" - O.D.	1
8	0300773	Connector - 3/4" Tube x 3/4" NPT - Male	2	20	0700732	Tube - 3/4" - O.D.	1
9	0300774	Elbow - 90°, 3/4" Tube x 3/4" NPT - Male	3	21	0700733	Tube - 3/4" - O.D.	1
10	0300776	Male Branch Tee - 3/4" Tube Run x 3/4" NPT Branch	1	22	0700734	Tube - 3/4" - O.D.	1
11	0300777	Female Branch Tee	1	23	0700735	Cross Over Tube - 3/4" - O.D.	1
12	0300778	Tee - Union - 3/4" Tube	1				

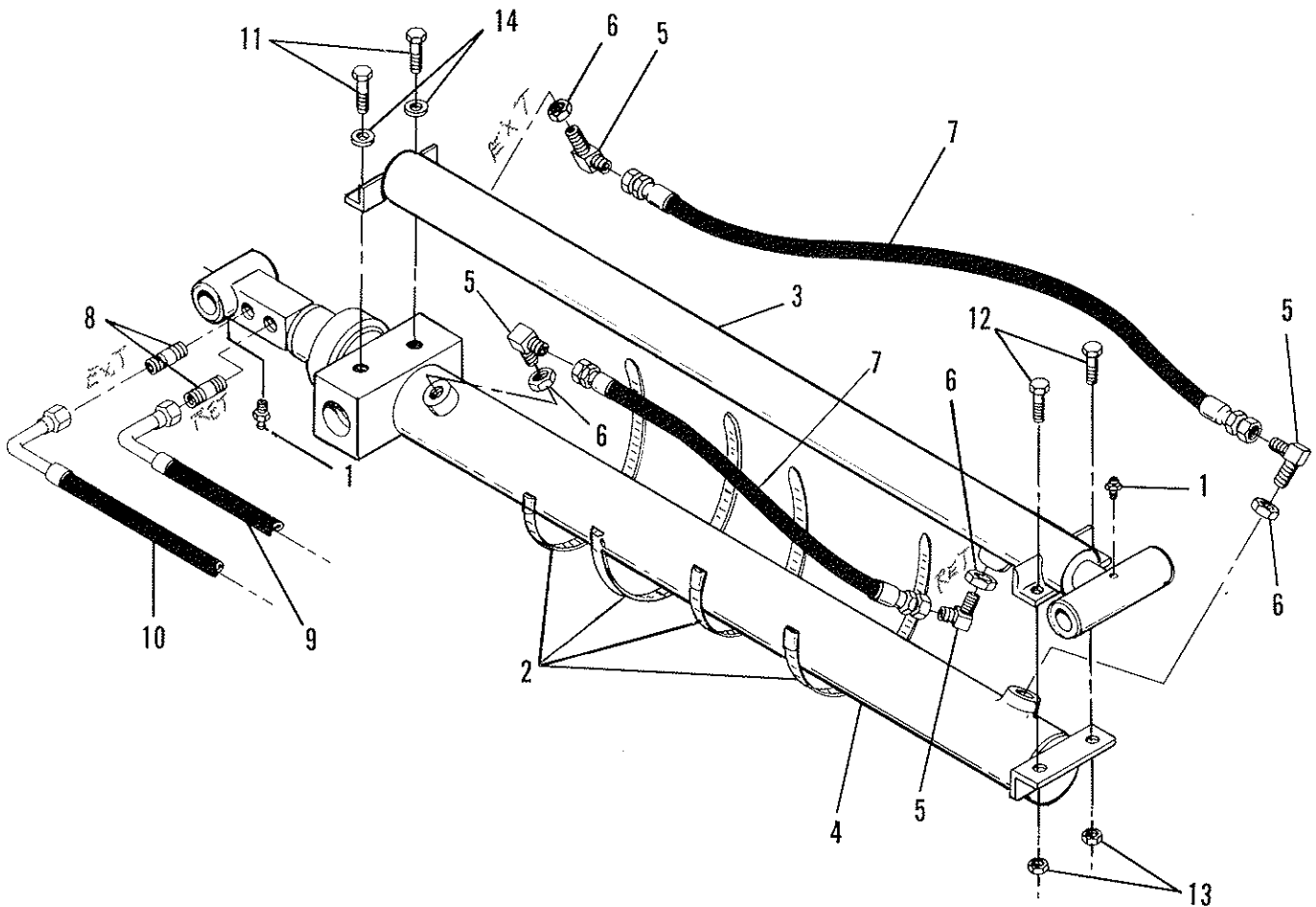

## EXTENSION CYLINDER ASSEMBLY

ITEM	PART NO.	DESCRIPTION	NO.REQ'D	ITEM	PART NO.	DESCRIPTION	NO.REQ'D
1	0300113	Grease Fitting	2	8	0301094	Straight Adapter	2
2	0300365	Hose Clamp	4	9	0301095	Hose 3/4" x 15-1/2" Long	1
3	0300436	3rd Stage Cylinder	1	10	0301098	Hose 3/4" x 23-1/2" Long	1
4	0300437	2nd Stage Cylinder	1	11	0400251	Cap Screw - 5/8" - 11 x 1-1/4"	2
5	0300615	Elbow - 90° 3/4"NPT x 3/4" JIC	4	12	0400252	Cap Screw - 5/8" - 11 x 1-1/2"	2
6	0300782	Locknut - 3/4" - 14	4	13	0400421	Nuts - 5/8" - 11 Nylok	2
7	0300887	Hose 3/4" x 90-1/2" Long	2	14	0400508	Lockwasher - 5/8" Helical	2

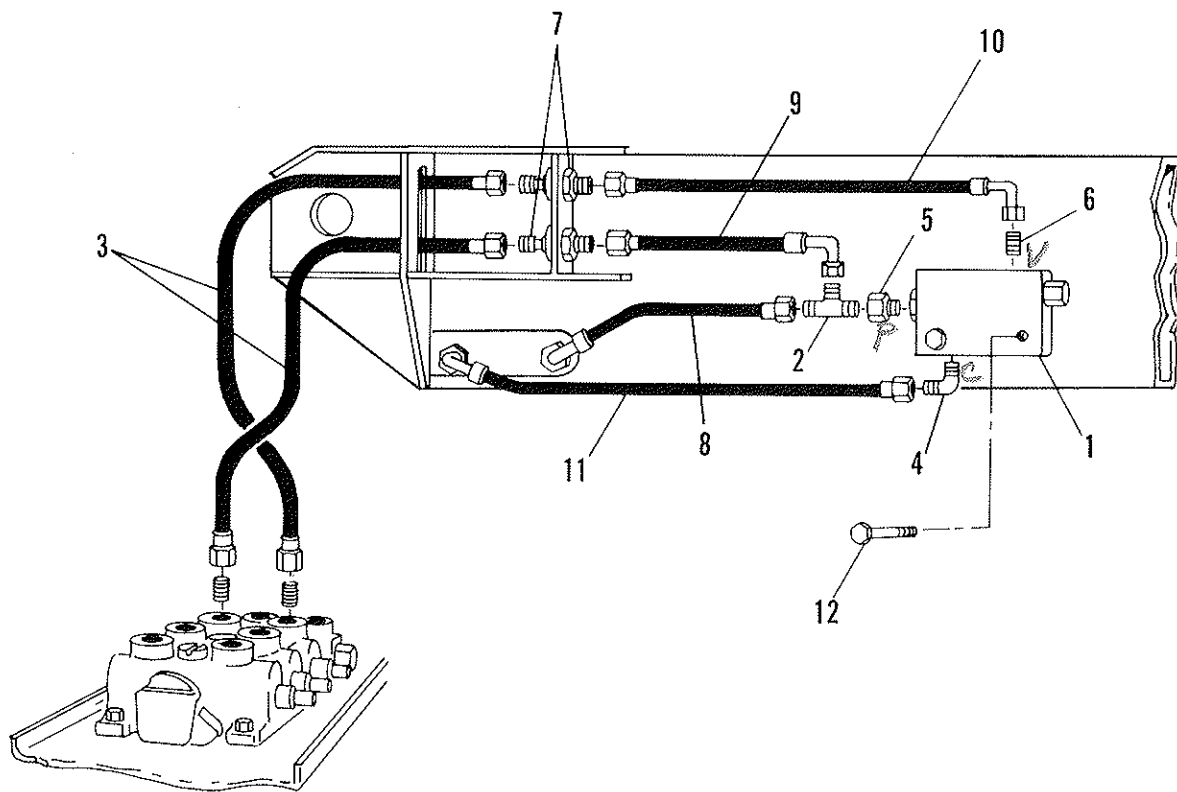

LEFT CONTROL VALVE

## EXTERNAL EXTENSION CYLINDER HYDRAULICS

ITEM	PART NO.	DESCRIPTION	NO.REQ'D	ITEM	PART NO.	DESCRIPTION	NO. REQ'D
1	0300310	Holding Valve	1	7	0301093	Bulk Head Union - 3/4" JIC x 3/4" JIC	2
2	0300553	Tee - 3/4" NPT x 3/4" JIC Run 3/4" JIC Branch	1	8	0301095	Hose - 3/4" x 15-1/2" Long	1
	0300607	Hose - 3/4" x 54" Long	2	9	0301096	Hose - 3/4" x 16-5/16" Long	1
4	0300615	Elbow - 90°, 3/4" NPT Male x 3/4" JIC Male	1	10	0301097	Hose - 3/4" x 22-1/2" Long	1
5	0300711	Reducer - 1/4" NPT - Male x 3/4" JIC Female	1	11	0301098	Hose - 3/4" x 23-1/2" Long	1
6	0301092	Male Adapter - 3/4" JIC x 3/4" NPT	1	12	0400107	Hex Head - 5/16" - 18 x 2-1/2"	2



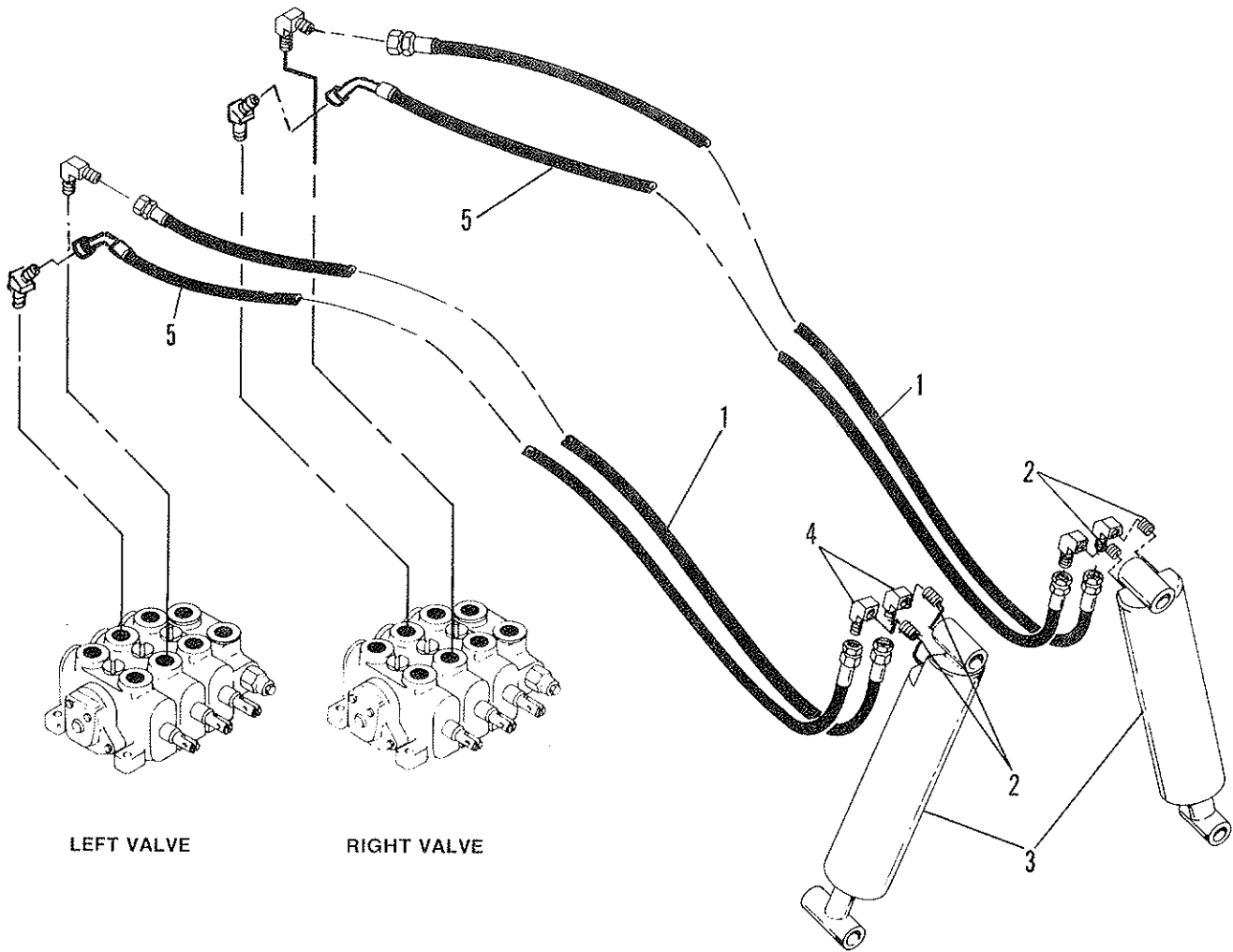

## JACK HYDRAULICS

ITEM	PART NO.	DESCRIPTION	NO.REQ'D	ITEM	PART NO.	DESCRIPTION	NO.REQ'D
1	0300654	Hose - Jack - 162" Long	2	4	0300689	Elbow - 90°, 1/2" NPT - FM x 1/2" JIC -- Male	4
2	0300678	Nipple - 1/2" SCH 80 Pipe 4" Long	4	5	0301332	Hose - Jack - 162" Long	2
3	0300680	Cylinders - Jack	2				

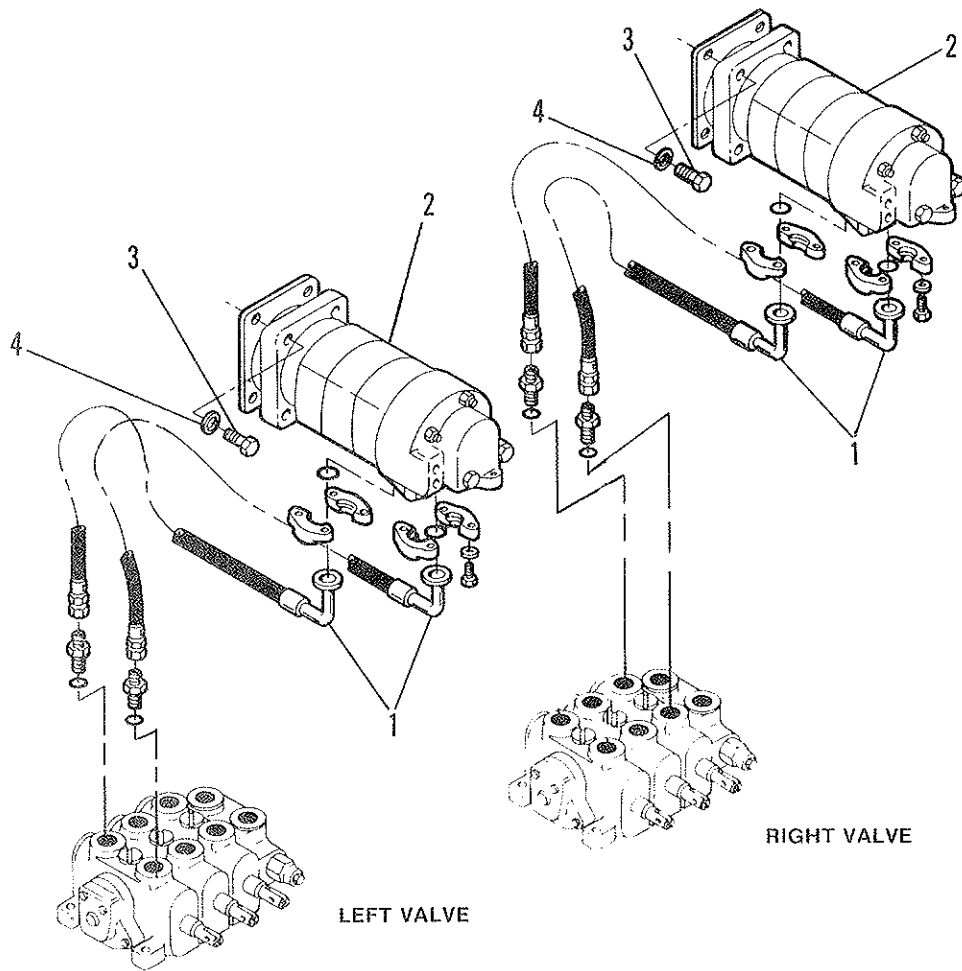

## HYDRAULICS - WINCH MOTORS

ITEM	PART NO.	DESCRIPTION	NO.REQ'D	ITEM	PART NO.	DESCRIPTION	NO.REQ'D
1	0300370	Hose - 3/4" x 50" Lg. (Incl. Split Flange & Hdw.)	4	3	0400185	Bolt - Hex, 1/2" - 13 x 2-1/2", Gr. 5	8
2	0300440	Motor - Winch	2	4	0400491	Lockwasher - 1/2" Helical	8

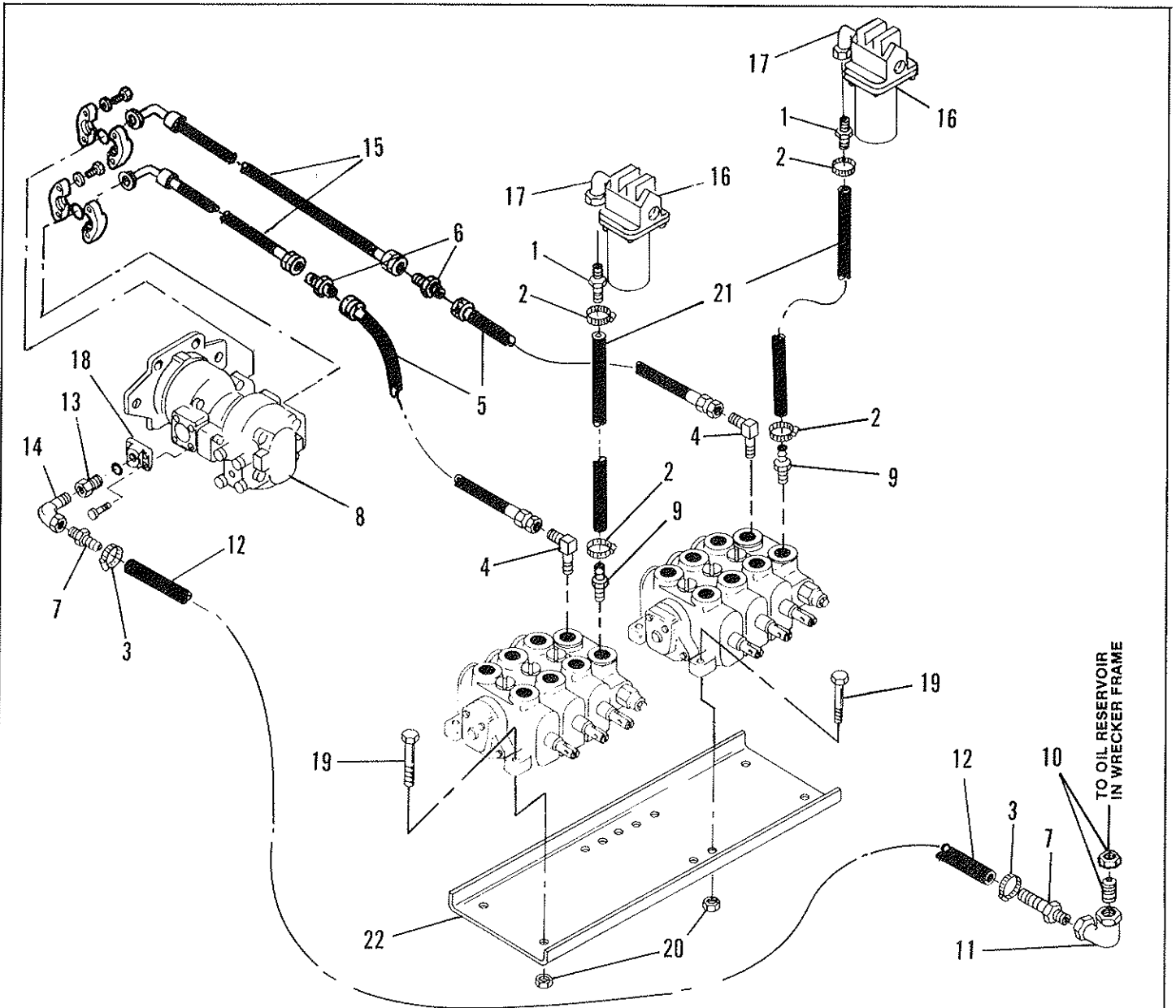

## PUMP AND FILTER HYDRAULICS

ITEM	PART NO.	DESCRIPTION	NO.REQ'D	ITEM	PART NO.	DESCRIPTION	NO.REQ'D
1	0300056	Hose Barb - 1" NPT x 1" I.D.	2	12	0300558	Suction Hose	1
2	0300071	Hose Clamp - 1"	4	13	0300592	2" NPT Female x 2-1/2" NPT Male	1
3	0300364	Hose Clamp - 2-1/4"	2	14	0300593	90° Street Elbow	1
4	0300401	Elbow 90°, 1" SAE "O" Ring x 1" JIC	2	15	0300611	High Pressure Hose - 66" Lg.	2
5	0300410	High Pressure Hose, 48" Lg.	2	16	0300628	Return Filter Spin On W/Housing	2
6	0300431	Straight Coupling - 1" JIC Male x 1" JIC Male	2	17	0300692	Street Elbow - 90°	2
7	0300434	Hose Barb 2" NPT - Male x 2" I.D.	2	18	0301090	Flange Adapter	1
8	0300441	Pump	1	19	0400124	Bolt - 3/8" - 16 x 2-1/2"	6
9	0300492	Hose Barb - 1" SAE "O" Ring x 1" I.D.	2	20	0400392	Nut - 3/8" - 16 Nylok	6
10	0300554	Pipe Nipple W/Nut and "O" Ring	1	21	0701325	Return Hose	2
11	0300555	Elbow - 90°	1	22	0701625	Channel - Valve - Mtg.	1



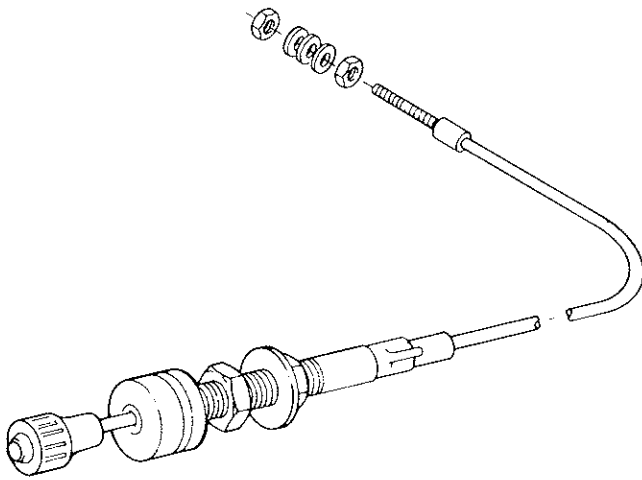

## THROTTLE CONTROL CABLE 0300722

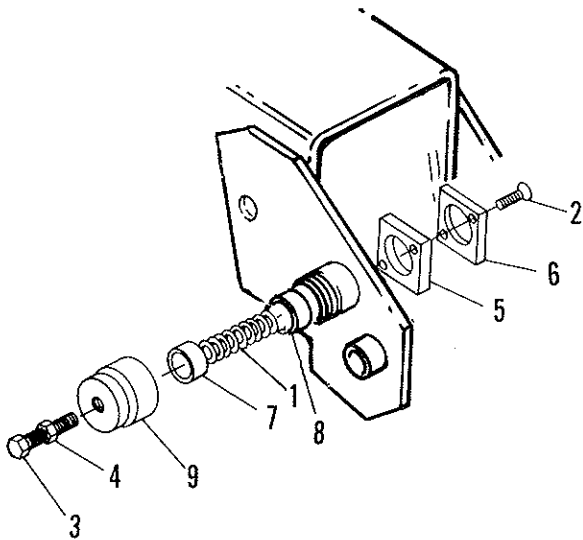

## DRAG BRAKE ASSEMBLY

ITEM	PART NO.	DESCRIPTION	NO.REQ'D
1	0301197	Spring	1
2	0400100	Mach. Screw - 5/16" - 18 x 3/4" Fl. Hd. Slotted, St. Stl.	2
3	0400145	Set Screw - 3/8" - 16 x 1-1/2"	1
4	0400393	Nut - 3/8" - 16, Hex - Jam Plated	1
5	0701340	Pad - Slide - Thick	1
6	0701341	Pad - Slide - Thin	1
7	0701343	Spacer	1
8	0701345	Pad	1
9	0800393	Cap - Weldment	1

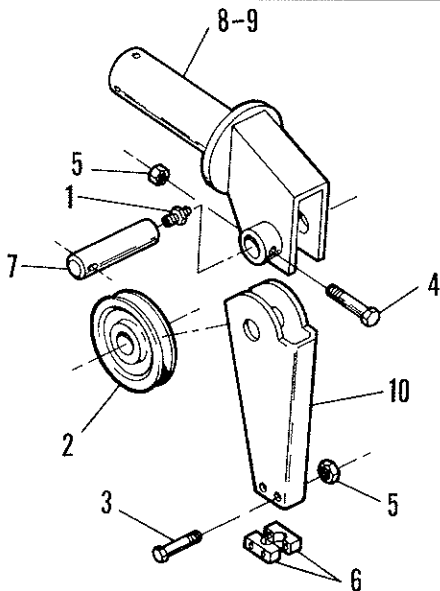

## BOOM END SWIVEL

ITEM	PART NO.	DESCRIPTION	NO.REQ'D
1	0300113	Grease Fitting	1
2	0300311	Sheave 12" Dia. x 2" Rim Width Br. Bushed	1
3	0400133	Bolt - 3/8" - 16 x 3" Hex Hd. Gr. 5 Pl.	2
4	0400140	Bolt - 3/8" - 16 x 4" Hex Hd. Gr. 5 Pl.	1
5	0400392	Nut 3/8" - 16 Nylok	3
6	0700511	Cable Guide - Bottom	2
7	0700563	Shaft - Sheave	1
8	0800222	Swivel Weldment - Left Hand	1
9	0800223	Swivel Weldment - Right Hand	1
10	0800224	Cable Guide Weldment	1

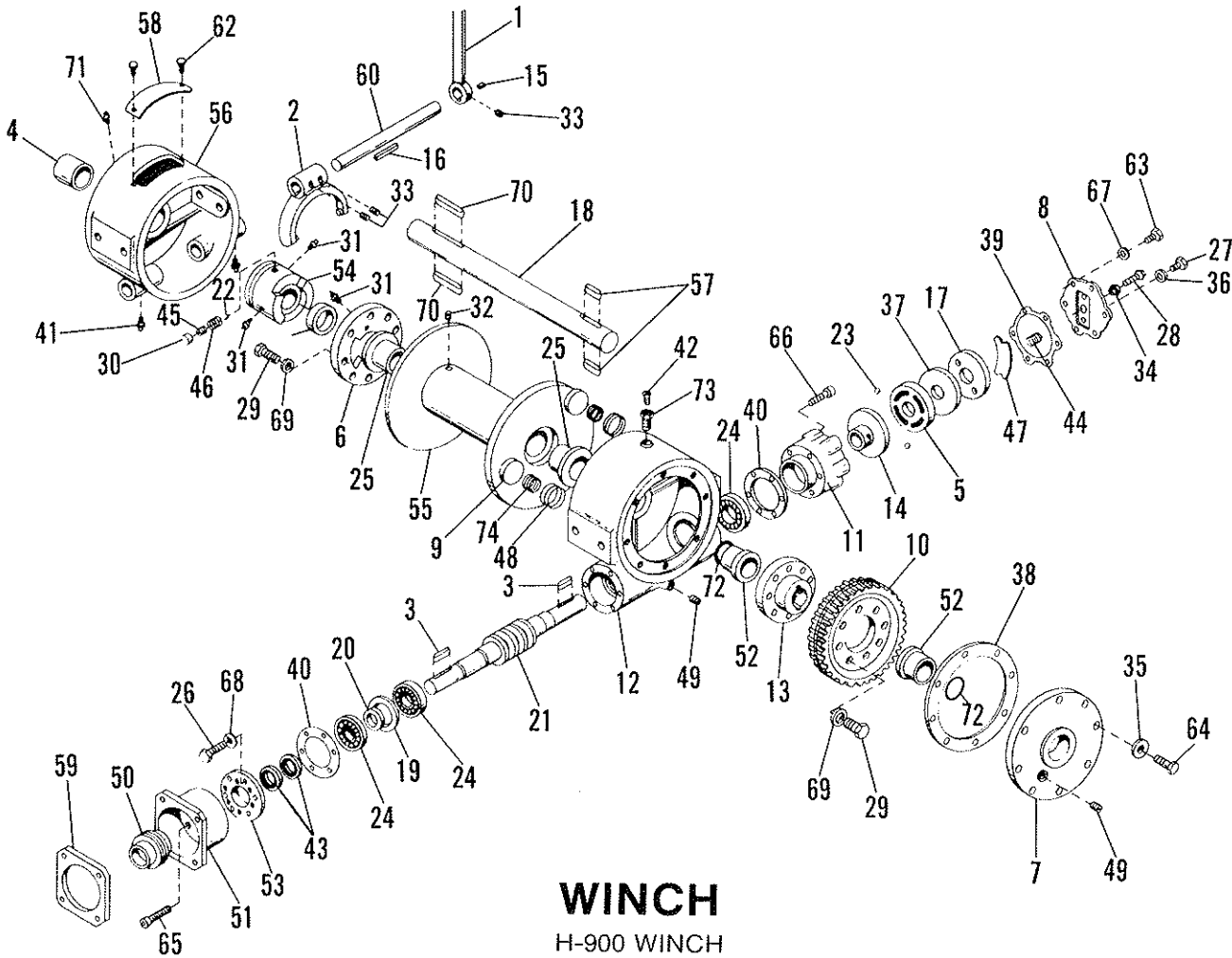

**WINCH**  
H-900 WINCH

ITEM	PART NO.	DESCRIPTION	NO.REQ'D	ITEM	PART NO.	DESCRIPTION	NO.REQ'D
1	0301083	Level	1	38	0301176	Gasket	1
2	0301123	Yoke Assembly	1	39	0301177	Gasket	1
3	0301124	Key	2	40	0301178	Gasket	2
4	0301125	Bushing	1	41	0301179	Lubrication Fitting	2
5	0301126	Cam Brake	1	42	0301180	Relief Fitting	1
6	0301128	Clutch Plate	1	43	0301182	Oil Seal	2
7	0301130	Gear Housing Cover	1	44	0301183	Spring	1
8	0301131	Brake Cover	1	45	0301184	Spring	1
9	0301132	Drag Brake Shoe	2	46	0301185	Spring	1
10	0301134	Work Gear	1	47	0301186	Spring	1
11	0301137	Brake Housing	1	48	0301187	Spring	2
12	0301138	Gear Housing	1	49	0301188	Pipe Plug	2
13	0301139	Gear Hub	1	50	0301239	Coupling Assembly	1
14	0301140	Brake Hub	1	51	0301240	Adapter	1
15	0301141	Key	1	52	0301241	Bushing	2
16	0301142	Key	1	53	0301242	Bearing Cap	1
17	0301145	Retainer Plate	1	54	0301243	Jaw Clutch	1
18	0301146	Drum Shaft	1	55	0301244	Drum	1
19	0301150	Bearing Outer Spacer	1	56	0301245	Clutch Housing	1
20	0301151	Bearing Inner Spacer	1	57	0301246	Key	2
21	0301152	Worm	1	58	0301247	Plate Cover	1
22	0301154	Clutch Ball	1	59	0301248	Hydraulic Adapter Plate	1
23	0301155	Brake Ball	2	60	0301249	Shift Shaft	1
24	0301156	Ball Bearing	3	61	0301250	Drum Spacer	1
25	0301157	Bushing	2	62	0301253	Capscrew - 1/4" - 20 NC x 3.4" Lg. Hex Hd C P	2
26	0301160	Capscrew - 1/2" - 13 NC x 1-1/2" Lg. Hex Hd	6	63	0301254	Capscrew - 3/8" - 16 NC x 1-1/4" Lg. Hex Hd C P	6
27	0301161	Capscrew - 5/8" - 18 NF x 1-3/4" Hex Hd	2	64	0301256	Capscrew - 1/2" - 13 NC x 1-1/4" Hex Hd Gr 5	8
28	0301162	Capscrew - 5/8" - 18 NF x 2" Lg. Hex Hd	1	65	0301258	Capscrew - 3/8" - 16 NC x 1-1/2" Hx Soc Hd	6
29	0301163	Capscrew - 5/8" - 18 NF x 2-1/4" Hex Hd	16	66	0301259	Capscrew - 1/2" - 13 NC x 1-3/4" Hx Soc Hd	6
30	0301165	Poppet Screw 1/2" - 20 NF Hd less Dr Slot	1	67	0301260	Lockwasher - 3/8" Medium Section	6
31	0301166	Lubrication Fitting	3	68	0301261	Lockwasher - 1/2" I.D. Med Sec C P	6
32	0301167	Setcrew 1/2" - 13 NC x 3/4" Lg. Allen Hd	1	69	0301263	Lockwasher - 5/8" Medium Section	16
33	0301168	5/16" - 18 NC x 3/8" Lg. Square Hd	3	70	0301264	Barth Key	2
34	0301169	Jam Nut - 5/8" - 18 NF Hex Hd	1	71	0301265	Lubrication Fitting	1
35	0301172	Washer - 1/2" I.D. Aluminum	8	72	0301266	O Ring	2
36	0301174	Washer - 5/8" Aluminum - Flat	2	73	0301267	Reducer	1
37	0301175	Disc Brake	1	74	0301268	Spring	2

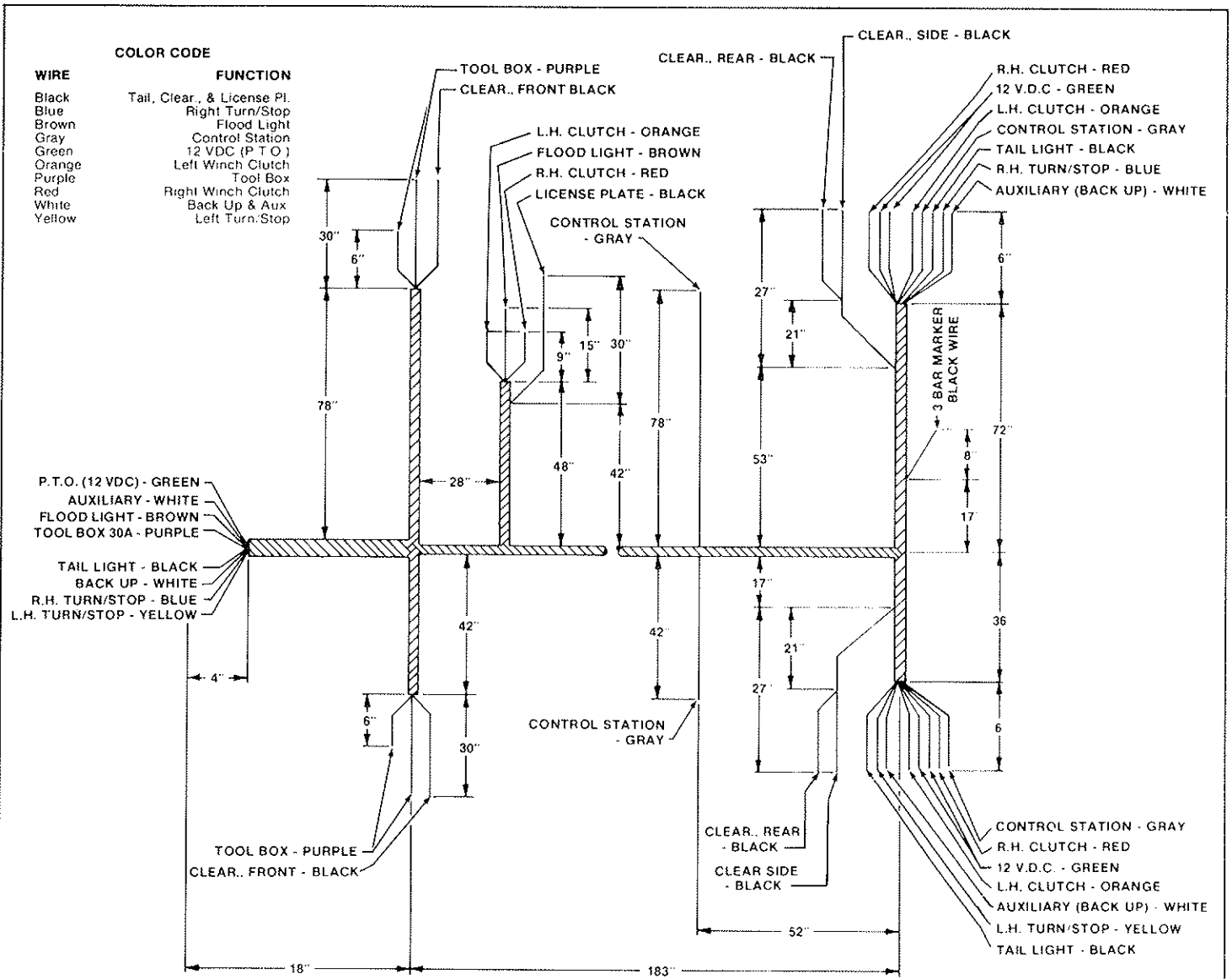

## 1040 WIRING HARNESS

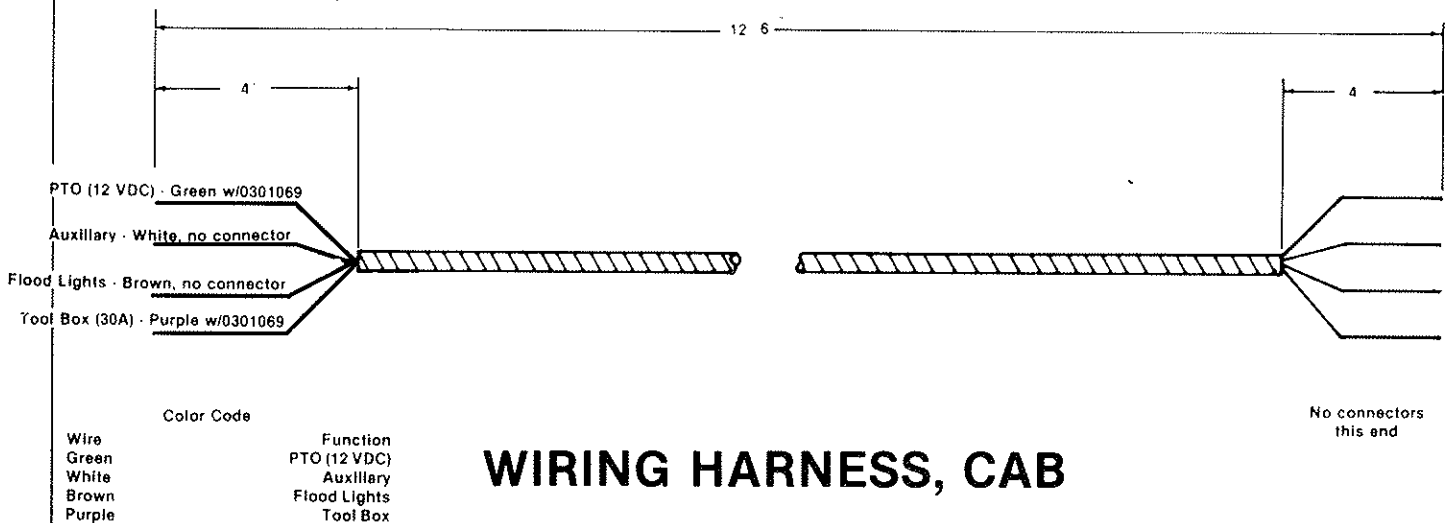

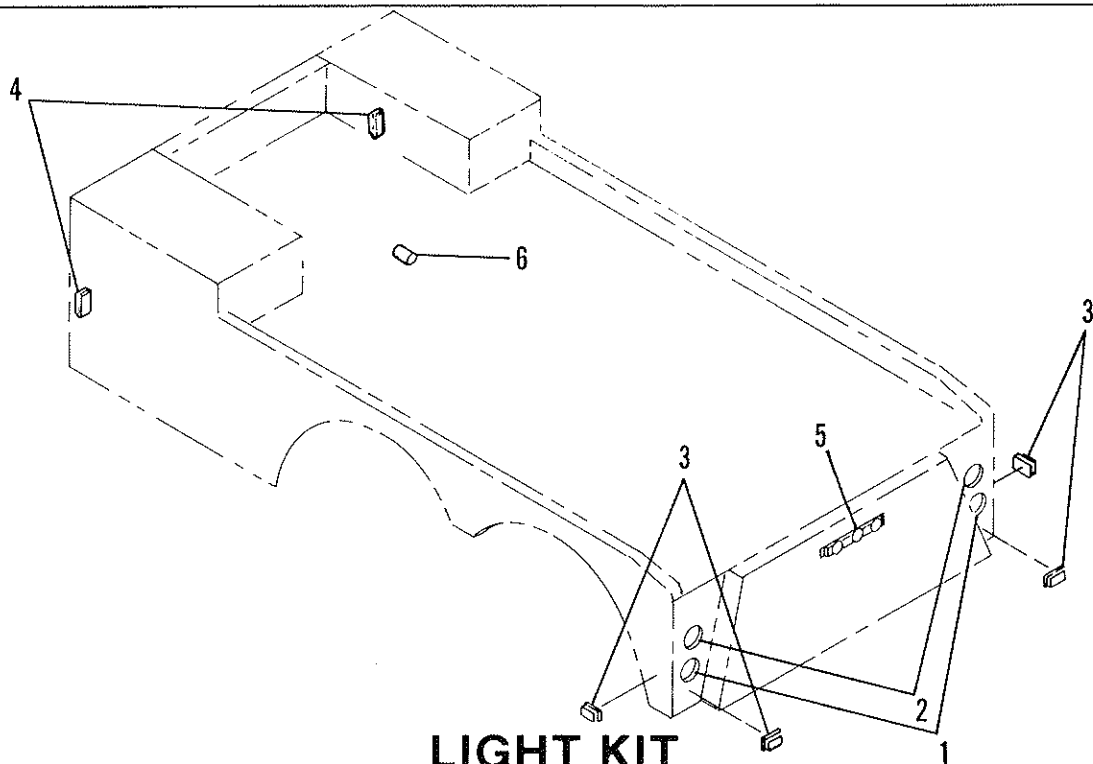

## LIGHT KIT

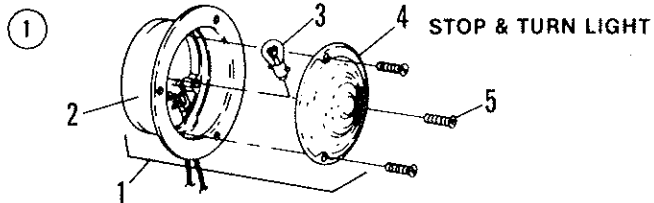

- |   |   |
|---|---|
| <ul style="list-style-type: none"> <li>1. Light, Stop &amp; Turn - Complete</li> <li>2. Housing, Stop &amp; Turn Light</li> <li>3. Bulb, Stop &amp; Turn Light</li> <li>4. Lens, Stop &amp; Turn Light - Red</li> <li>5. Screw, Lens</li> </ul> | <ul style="list-style-type: none"> <li>0300501</li> <li>0300497</li> <li>0300498</li> <li>0300499</li> <li>0300500</li> </ul> |
|---|---|

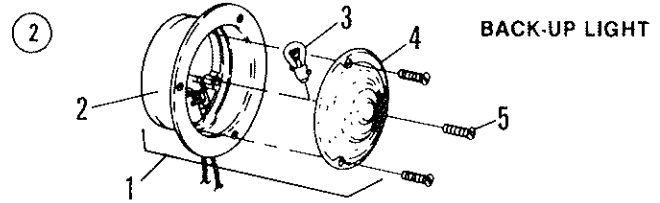

- |   |   |
|---|---|
| <ul style="list-style-type: none"> <li>1. Light, Back-Up - Complete</li> <li>2. Housing, Back-Up Light</li> <li>3. Bulb, Back-Up Light</li> <li>4. Lens, Back-Up Light - Clear</li> <li>5. Screw, Lens</li> </ul> | <ul style="list-style-type: none"> <li>0300505</li> <li>0300502</li> <li>0300503</li> <li>0300504</li> <li>0300500</li> </ul> |
|---|---|

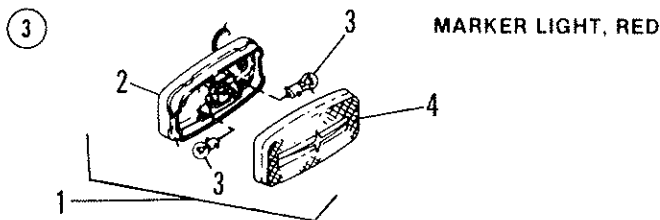

- |   |  |
|---|--|
| <ul style="list-style-type: none"> <li>1. Light, Marker Red - Complete</li> <li>2. Housing, Marker Light - Red</li> <li>3. Bulb, Marker Light</li> <li>4. Lens, Marker Light - Red</li> </ul> | <ul style="list-style-type: none"> <li>0300427</li> <li>0300506</li> <li>0300507</li> <li>0400508</li> </ul> |
|---|--|

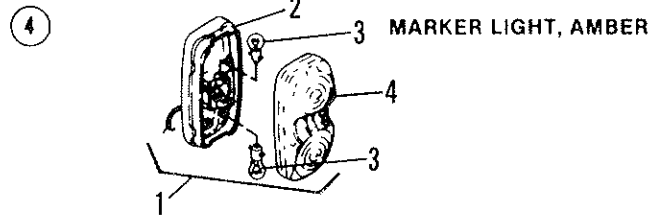

- |   |  |
|---|--|
| <ul style="list-style-type: none"> <li>1. Light, Marker - Amber - Complete</li> <li>2. Housing, Marker Light - Amber</li> <li>3. Bulb, Marker Light</li> <li>4. Lens, Marker Light - Amber</li> </ul> | <ul style="list-style-type: none"> <li>0300428</li> <li>0300509</li> <li>0300507</li> <li>0300510</li> </ul> |
|---|--|

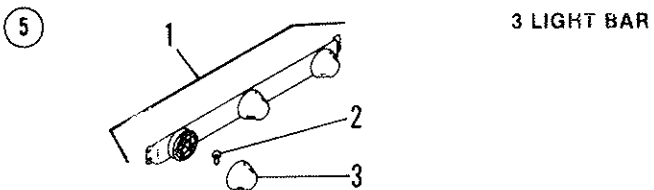

- |   |   |
|---|---|
| <ul style="list-style-type: none"> <li>1. 3 Light Bar Ass'y. - Complete</li> <li>2. Bulb, Marker Light</li> <li>3. Lens, 3 Light Bar</li> </ul> | <ul style="list-style-type: none"> <li>0300442</li> <li>0300507</li> <li>0300511</li> </ul> |
|---|---|

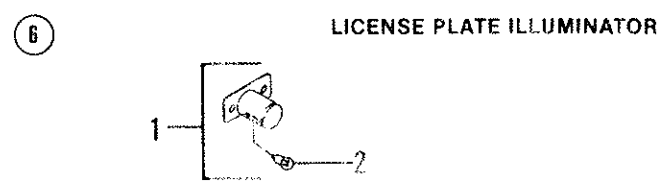

- |   |  |
|---|--|
| <ul style="list-style-type: none"> <li>1. License Plate Illuminator - Complete</li> <li>2. Bulb, License Plate - Illuminator</li> </ul> | <ul style="list-style-type: none"> <li>0300273</li> <li>0300512</li> </ul> |
|---|--|



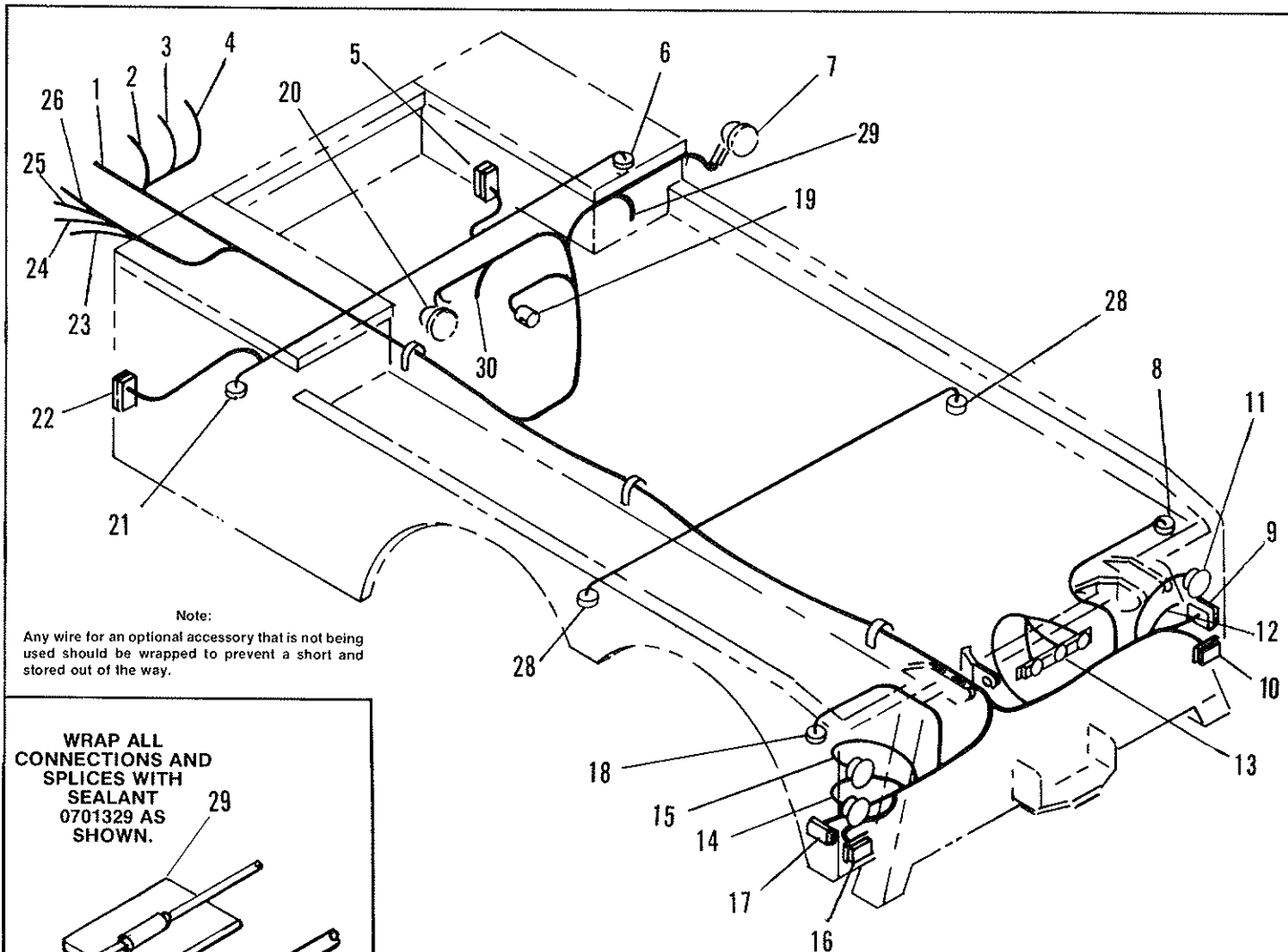

## WIRING INSTALLATION

ITEM	DESCRIPTION	WIRE COLOR	ITEM	DESCRIPTION	WIRE COLOR
1	Inline Fuse	Purple	16	Rear, Clearance, L.H.	Black
2	Switch Panel (Auxiliary) - (Opt.)	White	17	Light, Side Marker, L.H. (Red)	Black
3	Switch Panel (Floodlights) - (Opt.)	Brown	18	Light, Control Station (Rear) L.H. (Opt.)	Gray
4	Switch Panel (PTO) - (Opt.)	Green	19	Light, License Plate	Black
5	Light, Front Marker R.H. (Amber)	Black	20	Floodlight, L.H. - (Opt.)	Brown
6	Light, Tool Box, R.H. (Opt.)	Purple	21	Light, Tool Box, L.H. - (Opt.)	Purple
7	Floodlight, R.H. (Opt.)	Brown	22	Light, Front Marker, L.H. (Amber)	Black
8	Light, Control Station (Rear) R.H. (Opt.)	Gray	23	L. Turn & Stop	Yellow
9	Light, Side Marker, R.H. (Red)	Black	24	R. Turn & Stop	Blue
10	Rear Clearance, R.H.	Black	25	Tail Light & Clearance	Black
11	Light, Stop & Turn, R.H.	Blue	26	Back-Up	White
	Light, Tail	Black	27	Sealant Electrical Connection	
12	Light, Back-Up, R.H.	White	28	Light, Control Station (Fwd.) - (Opt.)	Gray
13	Light, Three Bar Marker	Black	29	Air Operated Free Spool (Rt. Side)	Red
14	Light, Back-Up, L.H.	White	30	Air Operated Free Spool (Lt. Side)	Orange
15	Light, Stop & Turn, L.H.	Yellow			
	Light, Tail	Black			



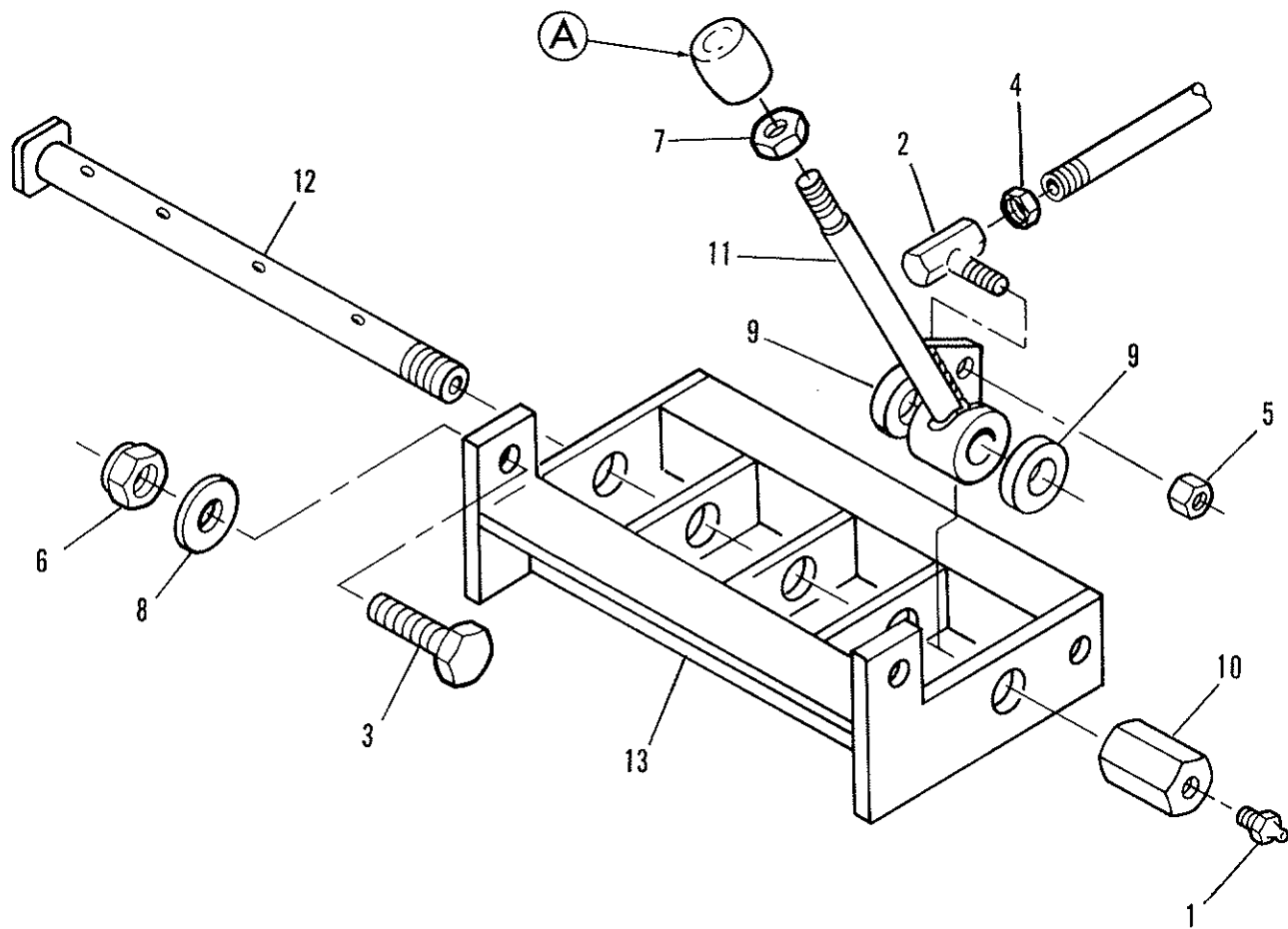

## 1040 REAR CONTROL HANDLE ASSEMBLY

ITEM	PART NO.	DESCRIPTION	NO. REQ'D	ITEM	PART NO.	DESCRIPTION	NO. REQ'D
1	0300113	Grease Fitting	1	8	0400480	Washer (Flat), 3/8", Pl.	12
2	0300736	Ball Joint	4	9	0700954	Spacer (Control Handle)	8
3	0400126	Cap Screw, Hex Hd., 3/8" - 16 x 1", Gr. 5, Pl.	4	10	0701169	Cap (Pipe)	1
4	0400383	Nut, 5/16" - 24	4	11	0800214	Handle (Control)	4
5	0400384	Nut, Nylok, 5/16" - 24	4	12	0800306	Shaft (Control Handle)	1
6	0400392	Nut, Nylok, 3/8" - 16, Pl.	2	13	0800308	Bracket (Mounting)	1
7	0400393	Nut (Jam), 3/8" - 16 Pl.	4	A		See Page 27	



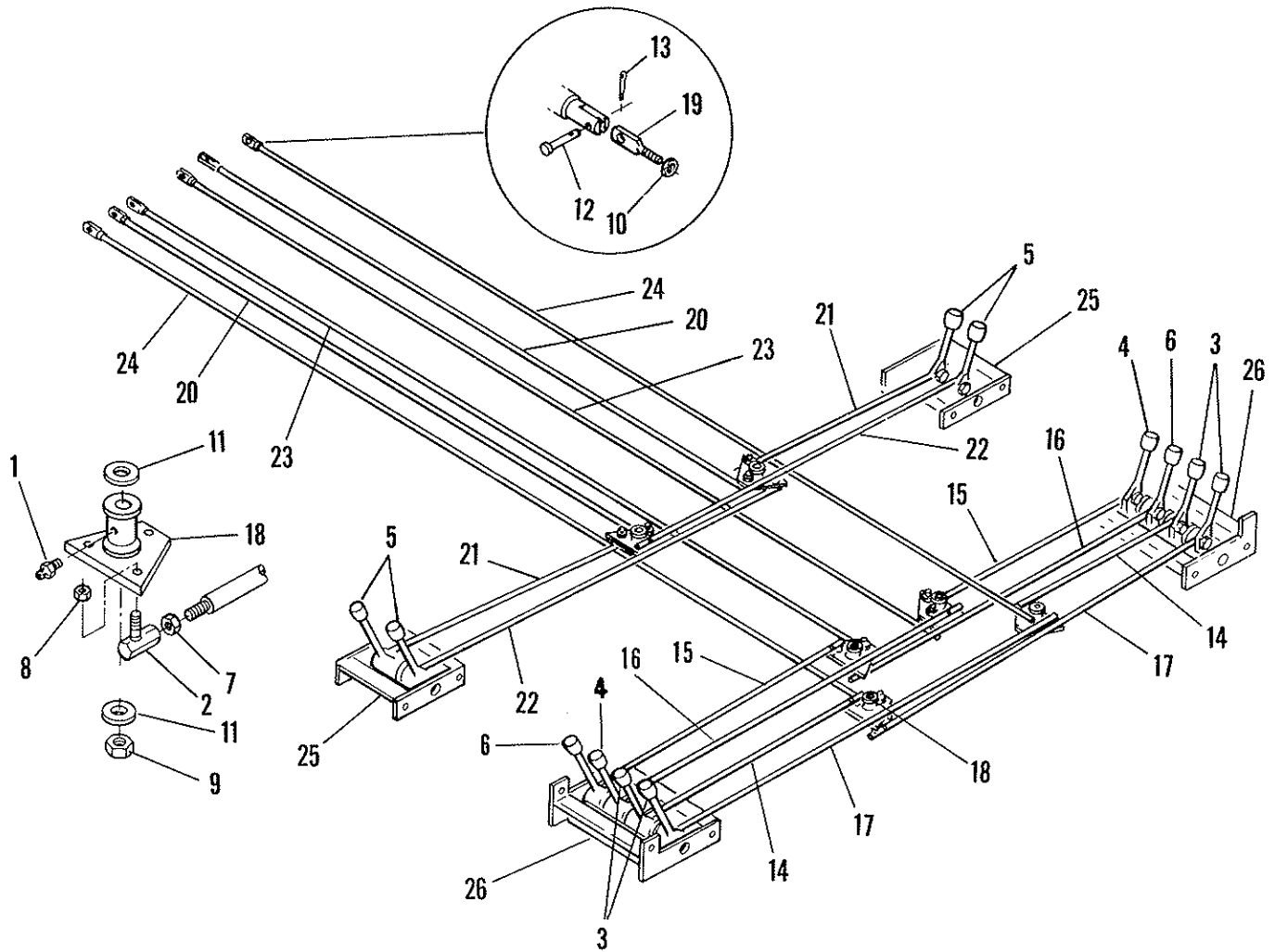

## CONTROL ROD ASSEMBLY

ITEM	PART NO.	DESCRIPTION	NO. REQ'D	ITEM	PART NO.	DESCRIPTION	NO. REQ'D
1	0300113	Grease Fitting	6	14	0800150	Cross Control Rod (27-3/16")	2
2	0300736	Ball Joint	2	15	0800151	Cross Control Rod (30-3/8")	2
3	0300834	Knob - Cable In-Out	18	16	0800154	Cross Control Rod (47-5/8")	2
4	0300835	Knob-Boom Up-Down	4	17	0800155	Cross Control Rod (50-5/8")	2
5	0300836	Knob - Jack Up-Down	2	18	0800156	Bell Crank Weldment	2
6	0300837	Knob - Boom In-Out	4	19	0800421	Clevis Weldment	6
7	0400383	Nut, 5/16" - 24 Hex, Plated	2	20	0800459	Longitudinal Control Rod (73-3/4")	6
8	0400384	Nut, 5/16" - 24 Hex, Nylok, Plated	18	21	0800465	Cross Control Rod (29-1/2")	2
9	0400408	Nut, 1/2"-13 Hex, Nylok, Plated	6	22	0800466	Cross Control Rod (48")	2
10	0400410	Nut, 1/2"-13 Hex, Plated	6	23	0800534	Longitudinal Control Rod (122-3/8")	2
11	0400492	Washer (Flat) 1/2"	12	24	0800535	Longitudinal Control Rod (127-1/4")	2
12	0400533	Pin (Clevis)	6	25	0900148	Control Handle Ass'y - Front	2
13	0400541	Cotter Pin	6	26	0900149	Control Handle Ass'y - Rear	2

# ADJUSTING PUMP OUTPUT PRESSURE

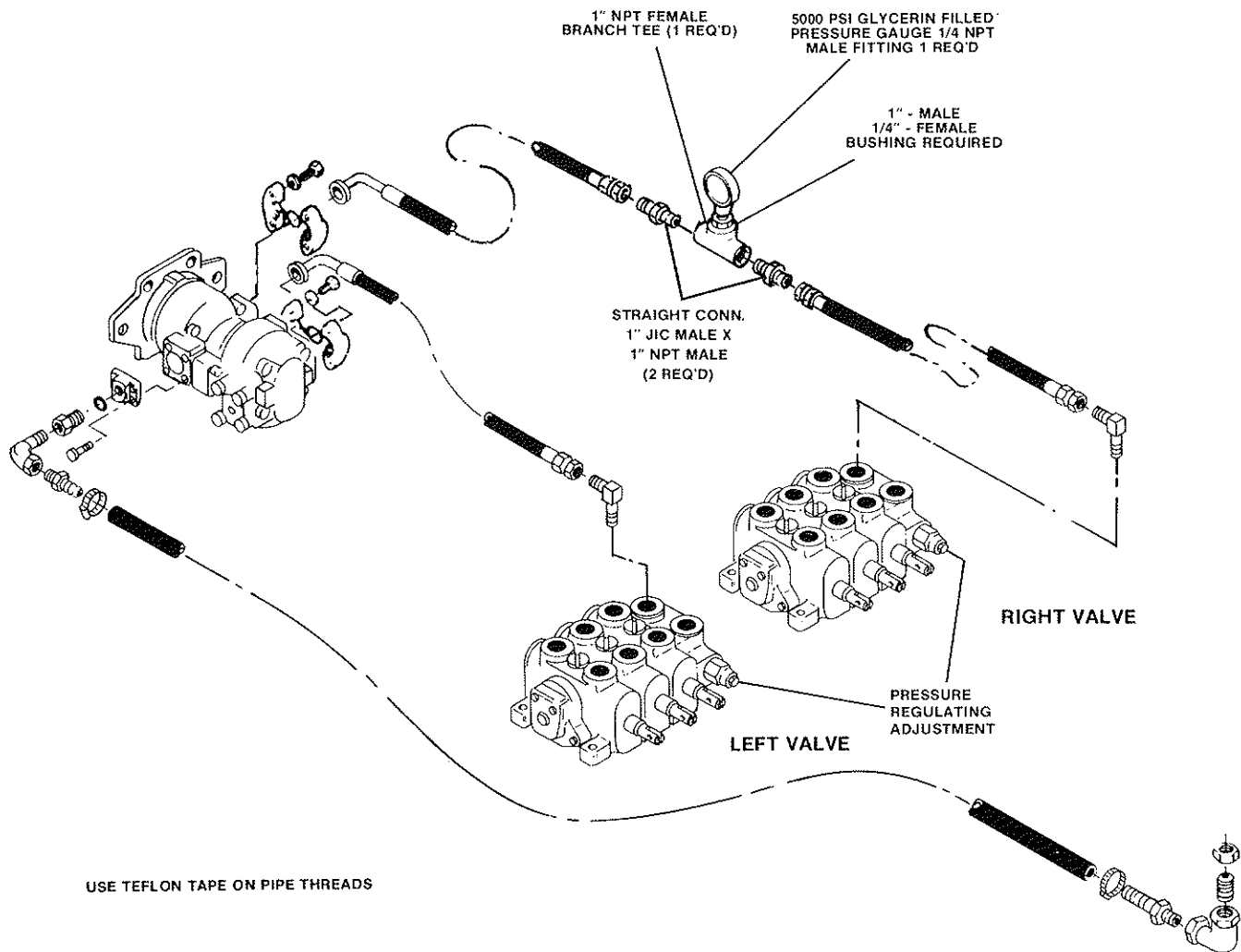

Pressure relief valves are factory preset at 3000 P.S.I. Should the need arise to check pressure, the following procedure is recommended:

1. Disconnect one high pressure hose assembly in the center. Do not disconnect at pump or control valve.
2. Install pressure gauge assembly between the two high pressure hoses.
3. Engage P.T.O.
4. Set the throttle at 1500 R.P.M.
5. Deadhead extension or elevation cylinder, depending on which pump-valve assembly gauge is attached to, and read gauge. Do not deadhead cylinder more than 5 sec. at a time.
6. Adjust pressure at control valve by removing cap nut, loosening jam nut and turning adjusting screw accordingly. One-half turn of the screw will substantially effect pressure.
7. Repeat Step 5. DO NOT EXCEED 3000 P.S.I., per valve.
8. Reconnect hose assembly and repeat procedure on second pump-valve assembly.
9. Reconnect hose assembly before returning unit to service.

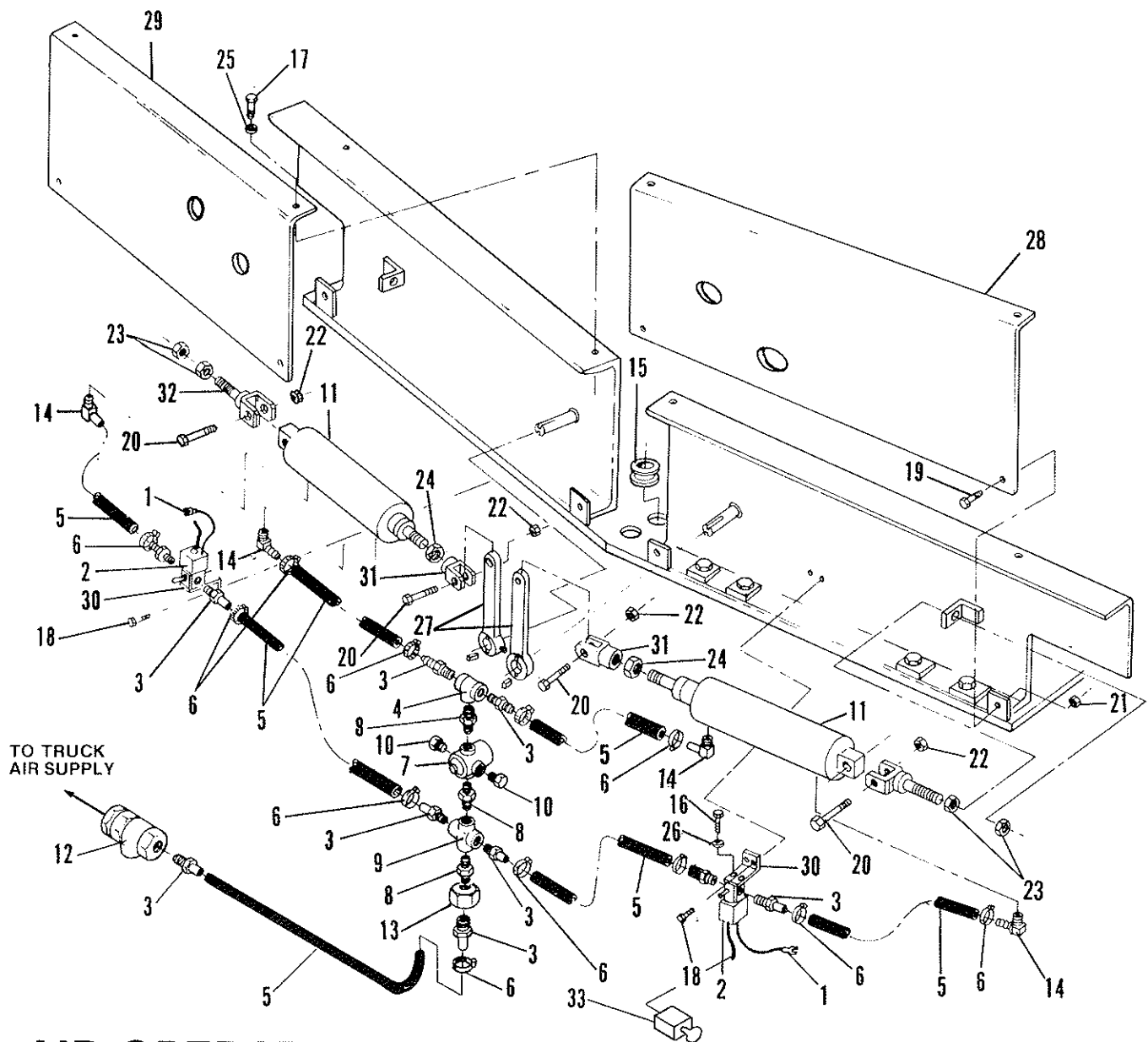

## AIR OPERATED FREE SPOOL CLUTCH CONTROL

ITEM	PART NO.	DESCRIPTION	NO. REQ'D	ITEM	PART NO.	DESCRIPTION	NO. REQ'D
1	0300166	Connector, Wire (Spade)	10	18	0400062	Screw - 1/4" - 20 x 3/4" Self Tapping, Hex Washer Hd. Pl.	4
2	0300324	Solenoid Valve	2	19	0400066	Cap Screw - 1/4" - 20 x 3/4" Hex Hd. Gr. 5, Pl.	4
3	0300594	Hose Barb Insert	10	20	0400104	Screw - 5/16" - 18 x 1-1/2" Hex Hd., Cap, Gr. 5, Pl.	4
4	0300595	Tee - Brass - 1/4" NPT FM	1	21	0400367	Nut - 1/4" - 20 Hex, Nylok, Plated	4
5	0300596	Hose - 1/4"	16 ft.	22	0400382	Nut - 5/16" - 18 Nylok	4
6	0300643	Clamp - 1/4"	14	23	0400410	Nut - Jam - 1/2" - 13 Reg. Pl.	4
7	0300743	Air Regulator	1	24	0400423	Nut 5/8" - 11 Reg. - Black	2
8	0300744	Close Nipple - Brass - 1/4" NPT M	3	25	0400452	Lockwasher - 1/4" Helical, Pl.	4
9	0300745	Cross - 1/4" NPT - FM	1	26	0400520	#10 Lockwasher, Helical Pl.	4
10	0300746	Plug - 1/4" NPT - M	2	27	0700707	Handle - Winch	2
11	0300749	Air Cylinder	2	28	0700831	Cover - Clutch - Left	1
12	0300788	Check - Valve - Excess Flow	1	29	0700832	Cover - Clutch - Right	1
13	0300895	Bulkhead Fitting	1	30	0701078	Solenoid Bracket	2
14	0300896	Hose Barb - 90° Ell.	4	31	0800267	Clevis - Air Cylinder Rod	2
15	0300897	Grommet	1	32	0800370	Clevis Bolt - Air Cylinder	2
16	0400041	#10 - 32 x 3/8" Screw, Self Tapping Pan Hd.	4	33	0300422	Switch	4
17	0400060	Cap Screw - 1/4" - 20 x 1/2 Hex Hd. Zinc Pl.	4				

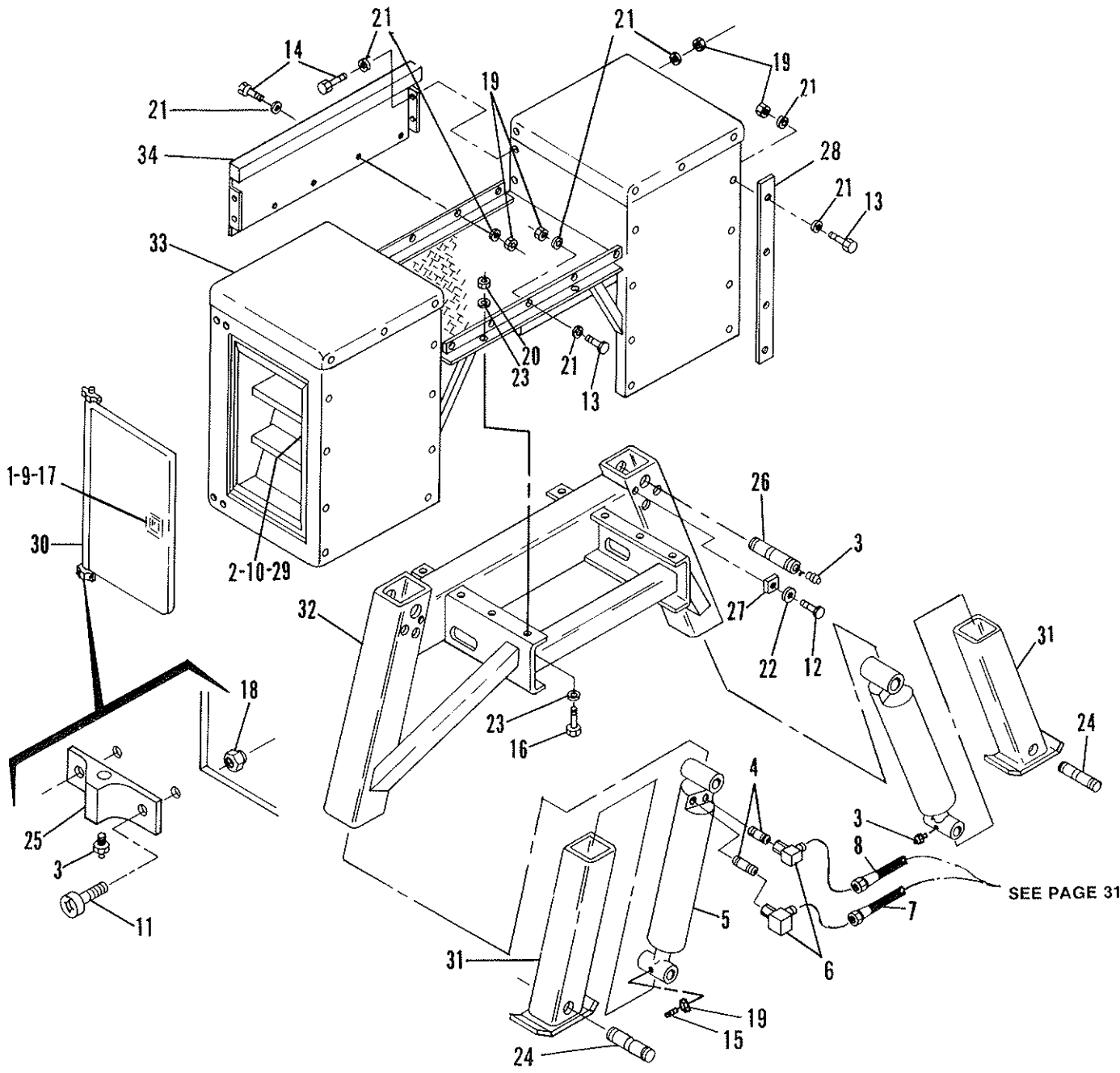

## 1040 FRONT OUTRIGGER OPTION

ITEM	PART NO.	DESCRIPTION	NO.REQ'D	ITEM	PART NO.	DESCRIPTION	NO.REQ'D
1	0300027	Latch, Toolbox	2	18	0400367	Nut, 1/4" - 20 Nylok, Plated	8
2	0300028	Striker	2	19	0400392	Nut, 3/8" - 16 Nylok	38
3	0300113	Grease Fitting (Straight)	8	20	0400408	Nut, 1/2" - 13 Nylok	8
4	0300678	Nipple	4	21	0400480	Washer, 3/8" Flat, Plated	72
5	0300680	Jack Cylinder	2	22	0400482	Lockwasher 3/8" Helical, Plated	2
6	0300689	Elbow - 90° 1/2" NPTF x 1/2" JIC Male	4	23	0400492	Washer, 1/2" Flat, Plated	16
7	0301216	Hose, Jack	2	24	0700884	Shaft, Jack Cylinder, Lower	2
8	0301217	Hose, Jack	2	25	0700963	Pivot Block Hinge	4
9	0400021	Screw, #8 - 32 x 1/2" Rd. Hd. Phillips	8	26	0701384	Shaft, Jack Cylinder - Upper	2
10	0400045	Screw, #10 - 32 x 1/2" Self Tap., Rd. Hd. Phillips	4	27	0701385	Retainer, Jack Shaft	2
11	0400071	Mach. Screw, 1/4" - 20 x 3/4" Rd. Hd. Phillips	8	28	0701471	Bar, Toolbox Filler	4
12	0400121	Cap Screw, 3/8" - 16 x 3/4" Hex Hd. Gr. 5 Plated	2	29	0701675	Spacer, Striker	4
13	0400122	Cap Screw, 3/8" - 16 x 1-1/4" Hex Hd. Gr. 5 Plated	25	30	0800385	Toolbox Door Weldment	2
14	0400132	Cap Screw, 3/8" - 16 x 1-1/2" Hex Hd. Gr. 5 Plated	11	31	0800431	Outrigger Tube - inner	2
15	0400139	Set Screw, 3/8" - 16 x 1-1/2" Allen	2	32	0800447	Front Outrigger Weldment	1
16	0400181	Screw, 1/2" - 13 x 1-1/2" Hex Hd., Gr. 5 Pl.	8	33	0800448	Front Deck Weldment	1
17	0400351	Nut, #8 - 32 Keps Nut W/Lockwasher	8	34	0800451	Front Panel Weldment	1

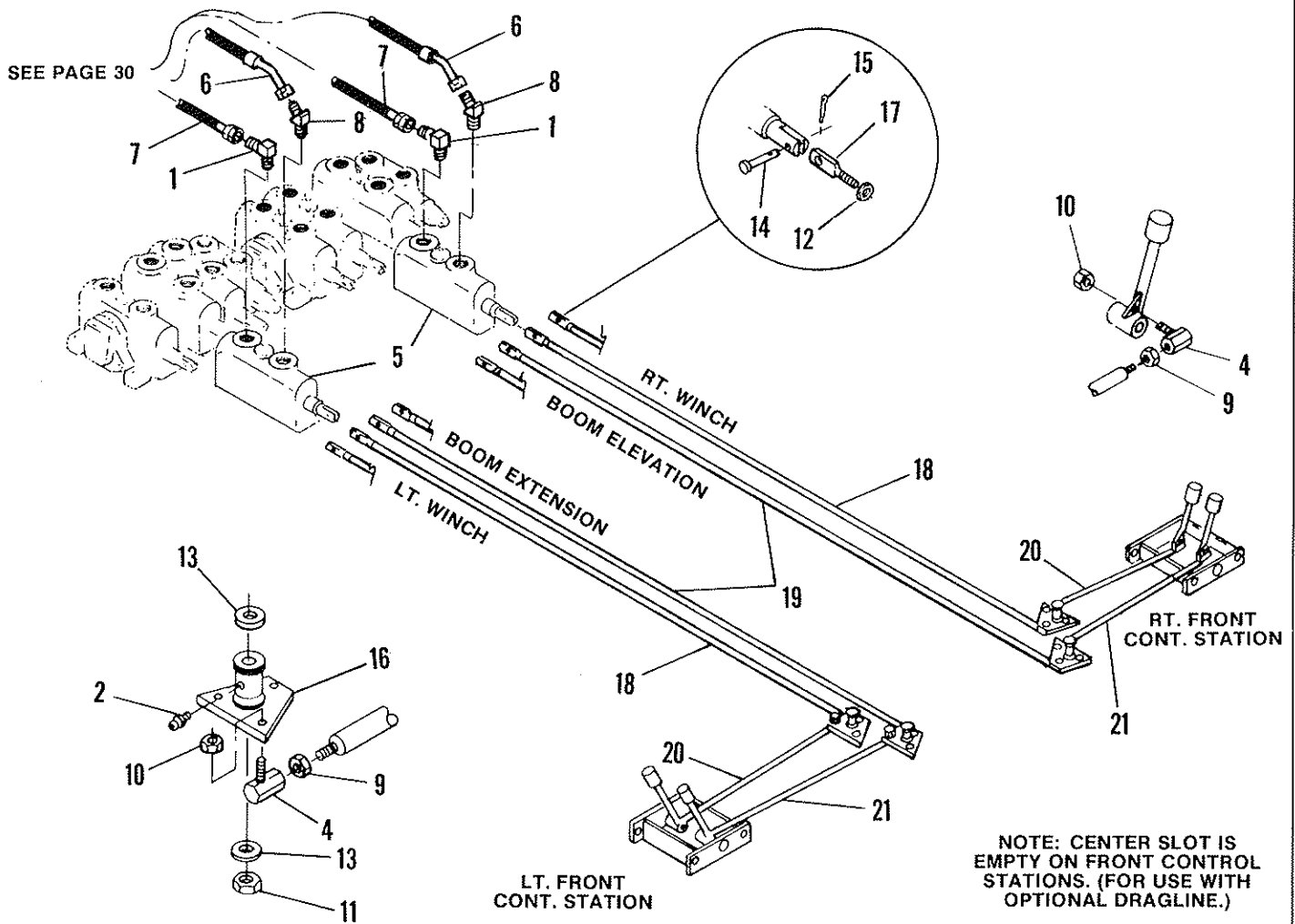

## OUTRIGGER CONTROL RODS W/FRONT OUTRIGGERS

ITEM	PART NO.	DESCRIPTION	NO. REQ'D	ITEM	PART NO	DESCRIPTION	NO. REQ'D
1	0300052	90° Elbow 1/2" JIC - 5/8" SAE	2	11	0400408	1/2" - 13 Hex Nut, Nylok, Plated	4
2	0300113	Grease Fitting (Straight)	4	12	0400410	1/2" - 13 Hex Jam Nut - Plated	4
3	0300490	Tie Rods (3 Stack Convert to 4 Stack) Set of 3 (Not Shown)	2 Sets	13	0400492	1/2" Flat Washer, Plated	8
4	0300736	Ball Joints	12	14	0400533	Clevis Pin, 1/4" x 1-1/4" Stainless Steel	4
5	0301195	Center Section - Housing #10 SAE Ports	2	15	0400541	1/16" x 3/4" Cotter Pin, Stainless Steel	4
6	0301216	Outrigger Hose - Front	2	16	0800156	Bell - Crank Weldment	4
7	0301217	Outrigger Hose - Front	2	17	0800421	Eye - Bolt Weldment	4
8	0301331	45° Ell - 5/8" SAE - 1/2" JIC	2	18	0800459	Long. Cont. Rod Weldment	2
9	0400383	5/16" - 24 Hex Nut, Plated	12	19	0800460	Long. Cont. Rod Weldment	2
10	0400384	5/16" - 24 Hex Nut, Nylok, Plated	12	20	0800465	Cross Control Rod Weldment	2
				21	0800468	Cross Control Rod Weldment	2



### Heavy Duty "D" Ring Assembly

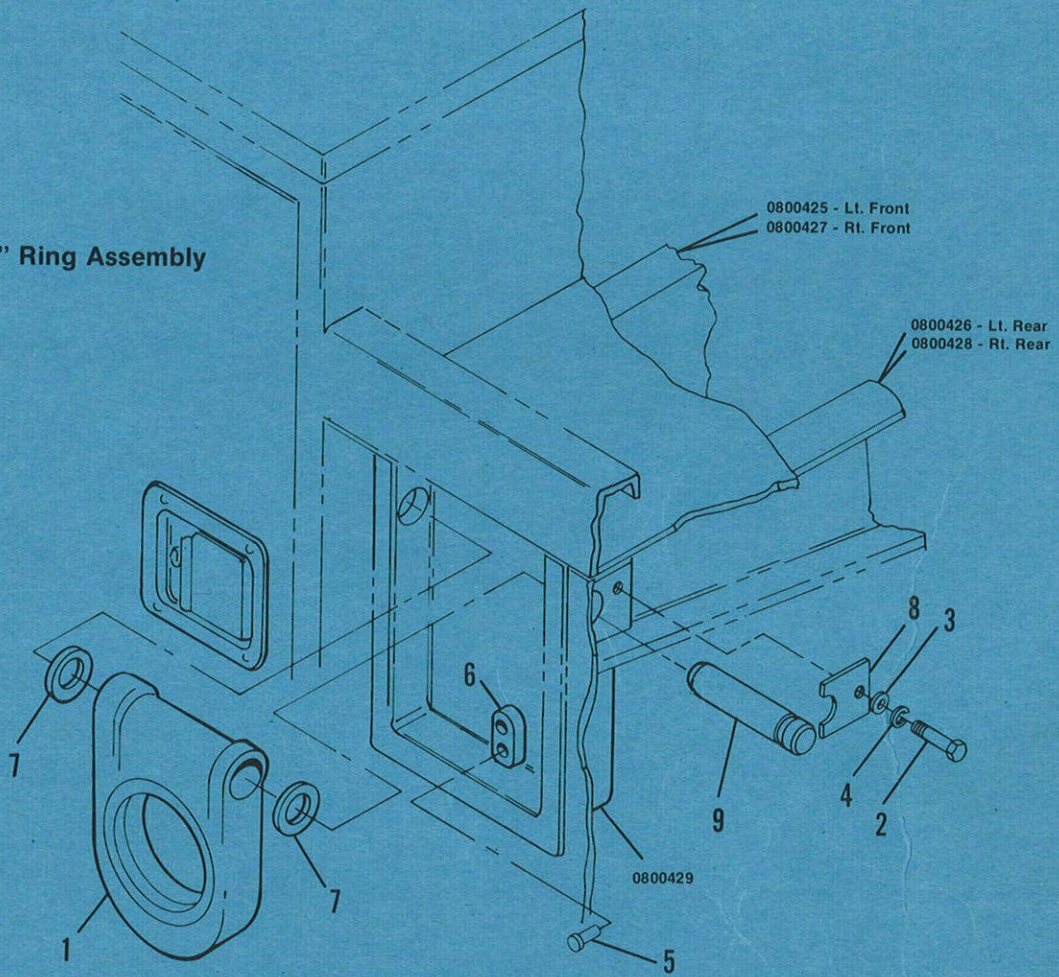

### "D" RING (OPTIONAL)

ITEM	PART NO.	DESCRIPTION	NO. REQ'D	ITEM	PART NO.	DESCRIPTION	NO. REQ'D
1	0301102	Heavy Duty "D" Ring	1	6	0701421	Bumper	1
2	0400121	Screw, 3/8"-16x3/4", Cap Hex Gr. 5	1	7	0701616	Washer, Shaft	2
3	0400480	Washer, 3/8" Flat, Zinc Pl.	1	8	0701693	Retainer, "D" Ring Shaft	1
4	0400482	Lockwasher, 3/8" Helical, Zinc Pl.	1	9	0701694	Shaft, 1 3/8" Dia.	1
5	0400566	Rivet, 1/4" Plated	2				



**CENTURY  
WRECKER  
CORPORATION**

1-75 At Ooltewah Exit • P. O. Box 120 • Ooltewah (Chattanooga), TN 37363 • Telephone: (615) 238-4171 or (615) 267-1831